

# **Blue2thprinting: {blue-[tooth]-printing}**

**Answering the question "WTF am I even looking at?!"**

**Xeno Kovah**

**OpenSecurityTraining2 (ost2.fyi)**

**& Dark Mentor LLC (darkmentor.com)**



# About Me

- 75% of my time is spent making free (as in beer), open access, and *open source* (Creative Commons licensed) classes for a non-profit I started, **OpenSecurityTraining2 (ost2.fyi)**





# About Me

- 75% of my time is spent making free (as in beer), open access, and *open source* (Creative Commons licensed) classes for a non-profit I started, **OpenSecurityTraining2 (ost2.fyi)**
- 25% of my time doing consulting and research for **Dark Mentor LLC**
  - The research is for fun, but is *also a trojan horse* to get me into conferences to tell you about OST2 ;)



**DARK MENTOR**





# OST2 Crew

In order of appearance

**Xeno Kovah**  
Arch1001 ~28 hours, Arch2001 ~27 hours  
Arch4001 ~14 hours, HW1101 ~6 hours  
Vulns1001 ~15 hours, Vulns1002 ~23 hours

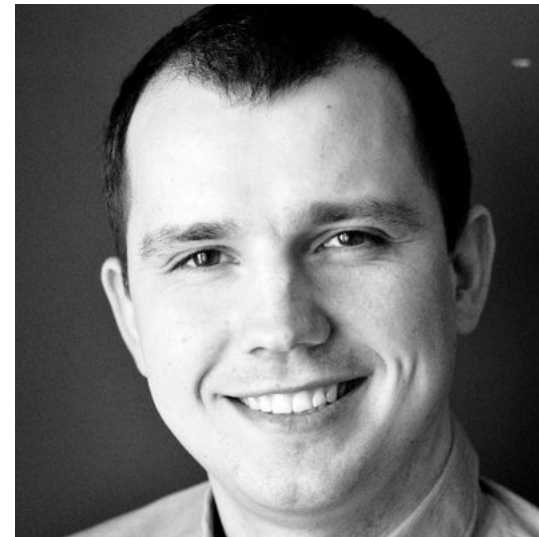
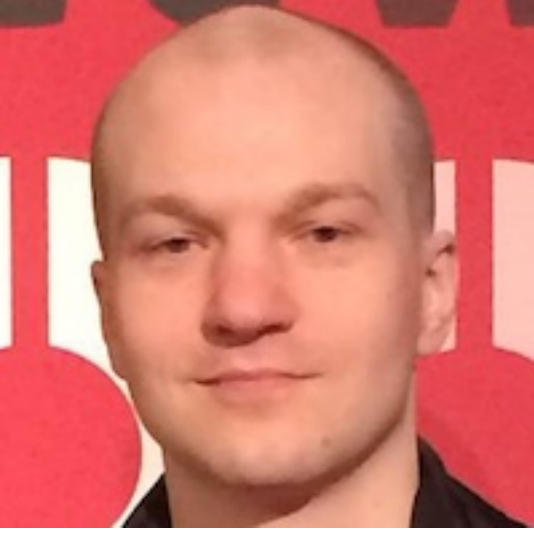

**Piotr Król**  
Arch4021 ~6 hours  
Arch4031 ~6 hours



**Michał Żygowski**  
Arch4021 ~6 hours



**Thaís Moreira Hamasaki**  
RE3201 ~6 hours



**Gal Zaban**  
RE3011 ~6 hours



**Kc Udonsi**  
Vulns1001 ~15 hours



**Cedric Halbronn**  
Dbg3011 ~6 hours  
Arch2821 ~5 hours  
Exp4011 ~33(!) hours



**Sina Karvandi**  
Dbg3301 ~16 hours



**What I Want To Know:**

**What Bluetooth Chip  
Is Inside Any Device**







 **TEXAS  
INSTRUMENTS**



 **SILICON LABS**

 **BROADCOM**<sup>®</sup>

?





**Why I Want To Know It:**

**So I Know if it's Vulnerable  
To a Firmware-Level Exploit**









**ARMIS®**  
**DARK MENTOR**



 **TEXAS**  
**INSTRUMENTS**

**SEMG**  
SECURE MOBILE NETWORKING

 **SILICON LABS**

 **BROADCOM®**



**ARMIS<sup>®</sup>**  
**DARK MENTOR**



**DARK MENTOR**



 **TEXAS**  
**INSTRUMENTS**

**SEMG**  
SECURE MOBILE NETWORKING

 **SILICON LABS**

 **BROADCOM<sup>®</sup>**



VersionPrint

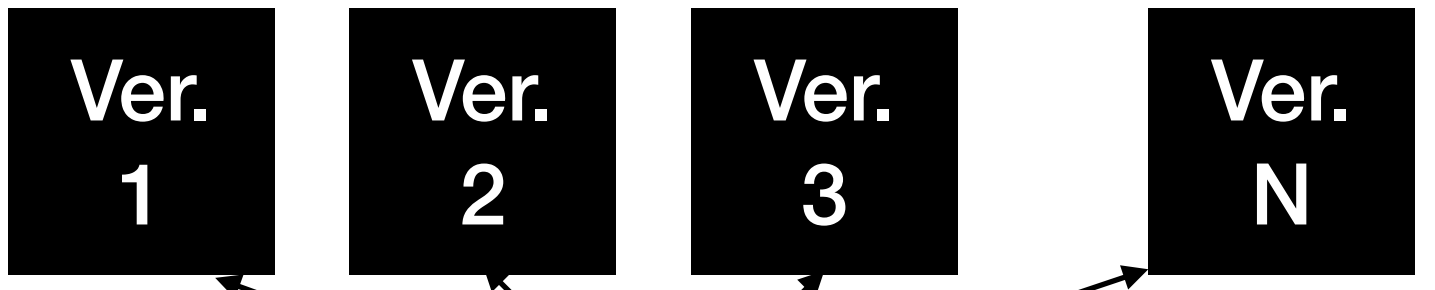

ChipPrint

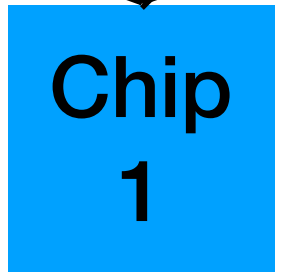



VersionPrint

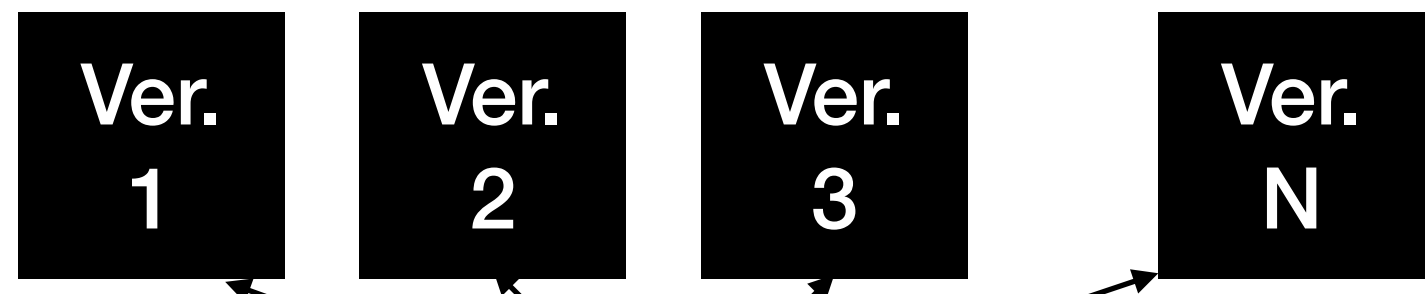

ChipPrint



ChipMakerPrint

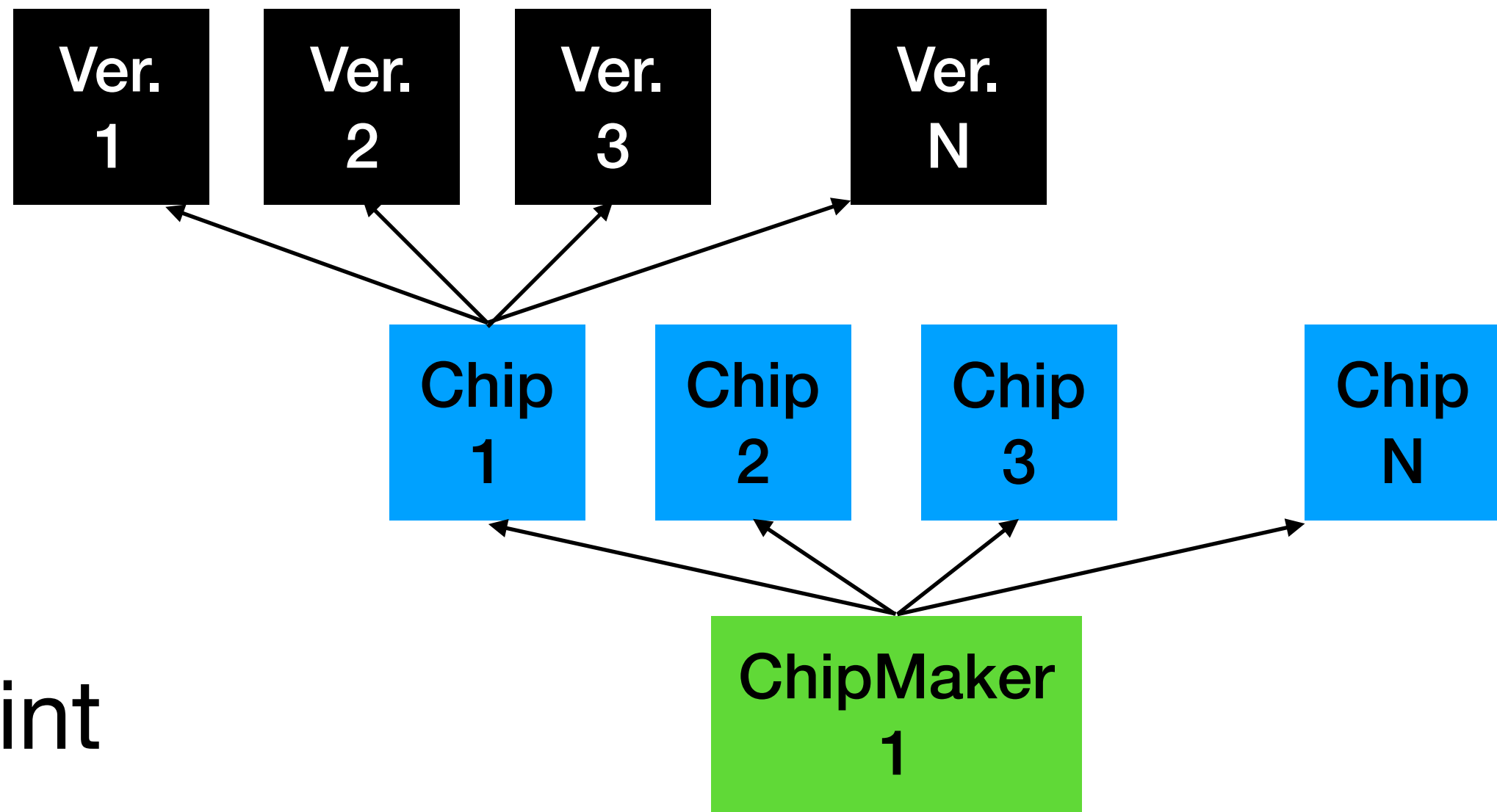



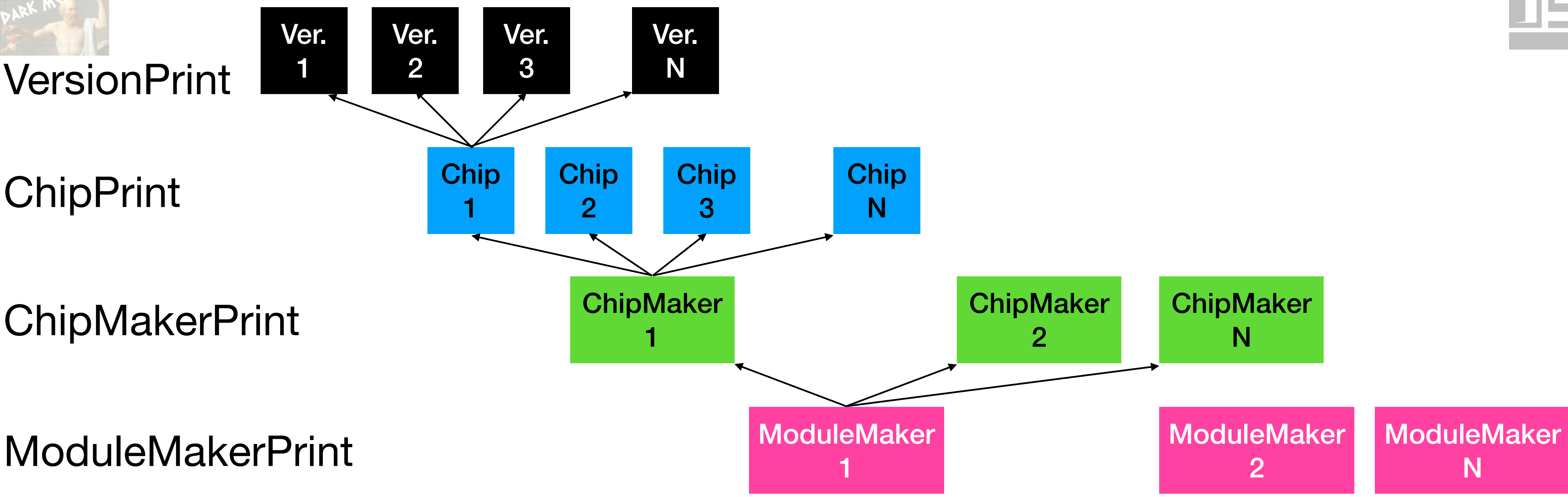

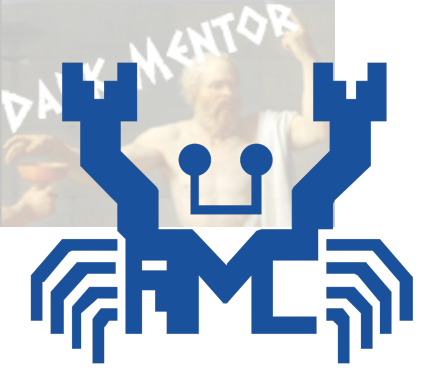

# REALTEK

ChipMaker

1

OST2  
.FYI

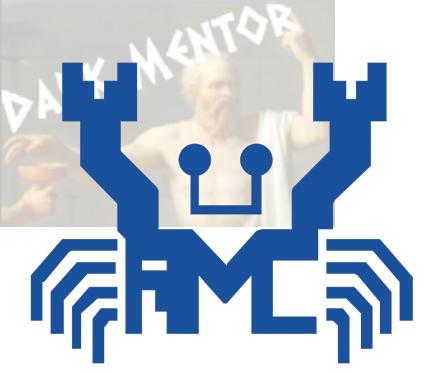

**REALTEK**

**ChipMaker**

**1**

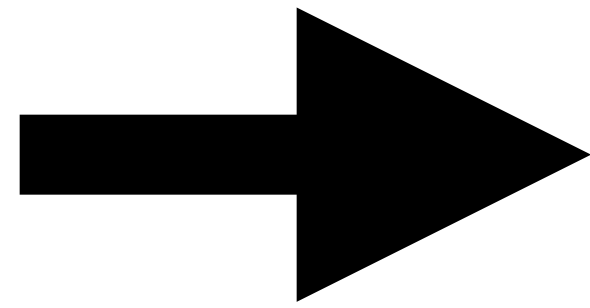

Ai-Thinker Technology

**ModuleMaker**

**1**

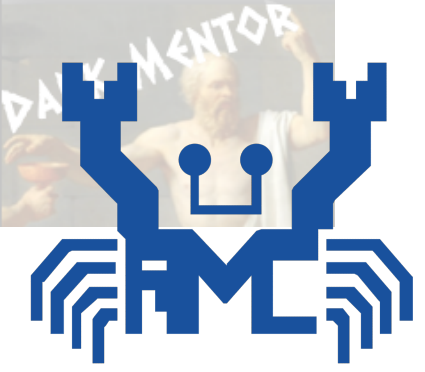

# REALTEK

ChipMaker  
1

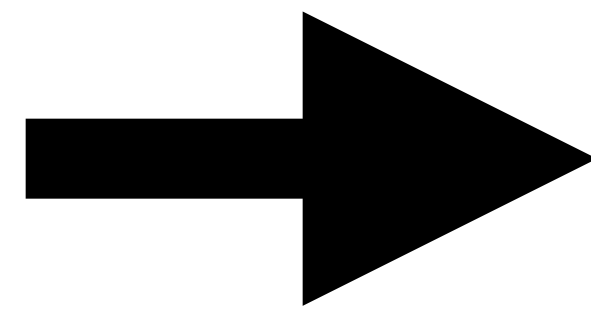

Ai-Thinker Technology

ModuleMaker  
1

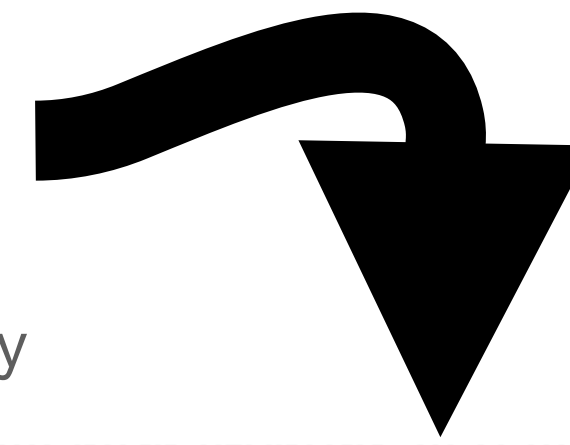

OST2  
.FYI

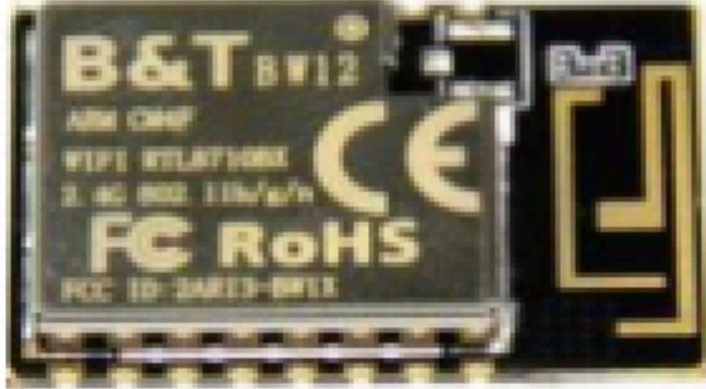
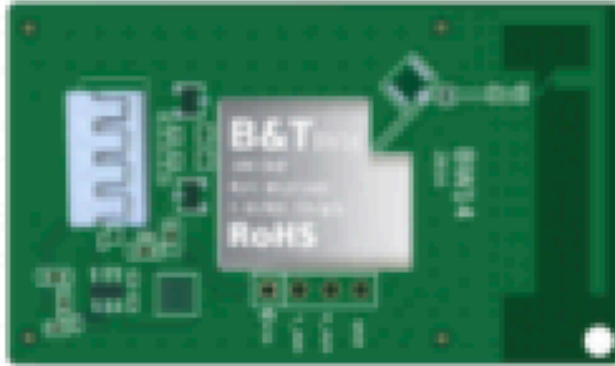
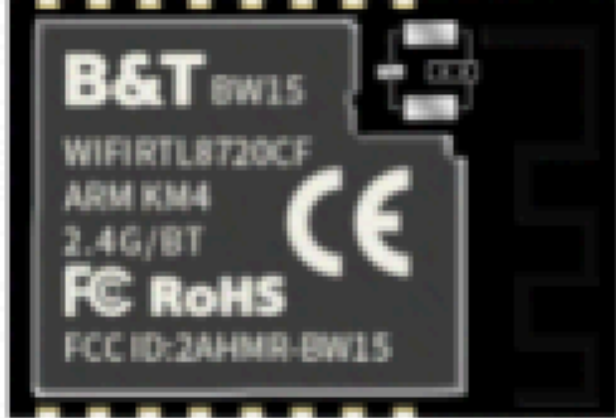
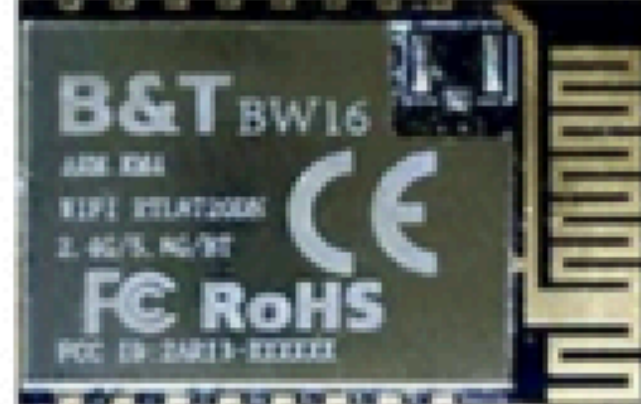
Model	BW12		BW15	BW16 (hot)
Picture				
Chip	RTL8710BX	RTL8710BX	RTL8720CF	RTL8720DN
Package	SMT-16	/	SMD-16	SMD-16
Size	24 x16x 3mm (LxWxH) ±0.2mm	50.5*29.2*3.3 (±0.2) mm	24*16*3(±0.2)MM	24*16*3(±0.2)MM
Antenna	on-board PCB/ IPEX antenna	on-board PCB/ IPEX antenna	on-board PCB/ IPEX antenna	on-board PCB/ IPEX antenna
Frequency range	24 <b>Module 1</b> Hz	240 <b>Module 2</b> Hz	2.40 <b>Module 3</b> GHz	2400-2484 <b>Module 4</b> 180-5825MHz
Bluetooth	<b>1</b>	<b>2</b>	BLE <b>3</b>	<b>4</b> 5.0
Operating temperature	-20~+85° C	-20°C~70°C	-40 °C ~ 85 °C	-20 °C ~ 70 °C
Storage temperature	-40 ~125°C	-40°C~125°C	-40 °C ~ 125 °C , < 90%RH	-40 °C ~ 125 °C , < 90%RH
Power supply	3.3±10%V	5V ~ 12V	Voltage 3.0 V ~3.6 V, current >500 mA	Voltage 3.0V ~ 3.6V, Typical 3.3V, Current >450mA
Interface	UART,I2C, SPI, GPIO, SWD, PWM	UART	UART/GPIO/ADC/PWM /IIC /SPI	UART/GPIO/ADC/PWM/IIC/SPI/SWD

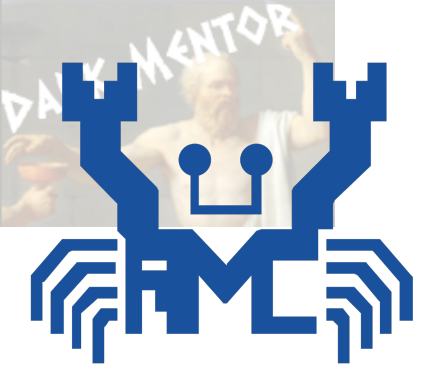

# REALTEK

ChipMaker  
1

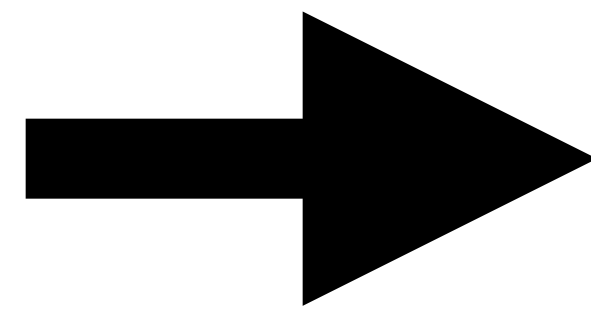

Ai-Thinker Technology

ModuleMaker  
1

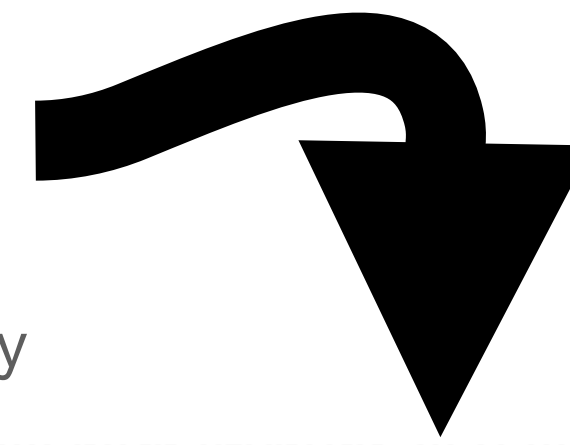

OST2  
.FYI

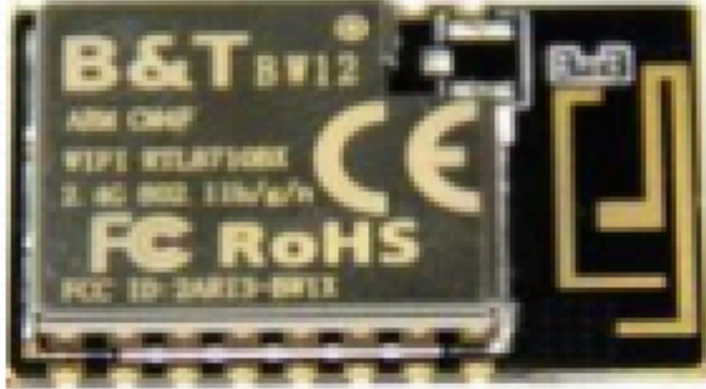
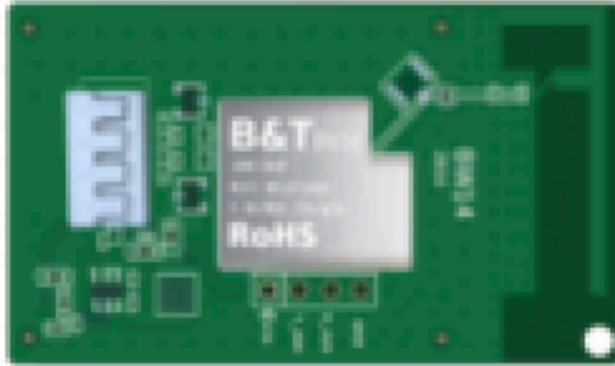
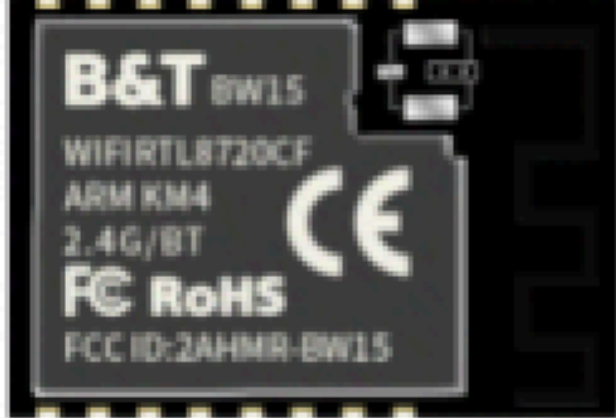
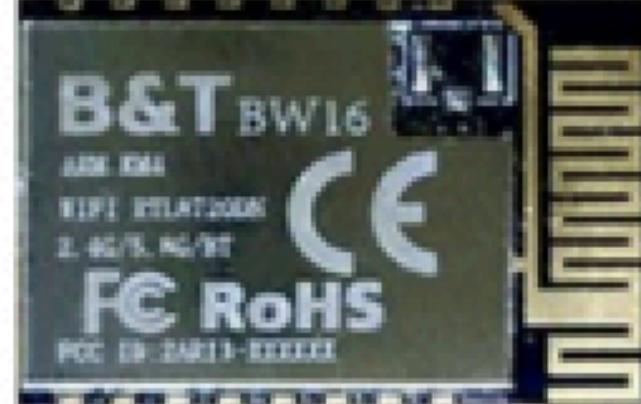
Model	BW12		BW15	BW16 (hot)
Picture				
Chip	RTL8710BX	RTL8710BX	RTL8720CF	RTL8720DN
Package	SMT-16	/	SMD-16	SMD-16
Size	24 x16x 3mm (LxWxH) ±0.2mm	50.5*29.2*3.3 (±0.2) mm	24*16*3(±0.2)MM	24*16*3(±0.2)MM
Antenna	on-board PCB/ IPEX antenna	on-board PCB/ IPEX antenna	on-board PCB/ IPEX antenna	on-board PCB/ IPEX antenna
Frequency range	24 <b>Module 1</b> Hz	240 <b>Module 2</b> Hz	2.40 <b>Module 3</b> GHz	2400-2484 <b>Module 4</b> 180-5825MHz
Bluetooth	<b>1</b>	<b>2</b>	BLE <b>3</b>	<b>4</b> 5.0
Operating temperature	-20~+85° C	-20°C~70°C	-40 °C ~ 85 °C	-20 °C ~ 70 °C
Storage temperature	-40 ~125°C	-40°C~125°C	-40 °C ~ 125 °C , < 90%RH	-40 °C ~ 125 °C , < 90%RH
Power supply	3.3±10%V	5V ~ 12V	Voltage 3.0 V ~3.6 V, current >500 mA	Voltage 3.0V ~ 3.6V, Typical 3.3V, Current >450mA
Interface	UART,I2C, SPI, GPIO, SWD, PWM	UART	UART/GPIO/ADC/PWM /IIC /SPI	UART/GPIO/ADC/PWM/IIC/SPI/SWD

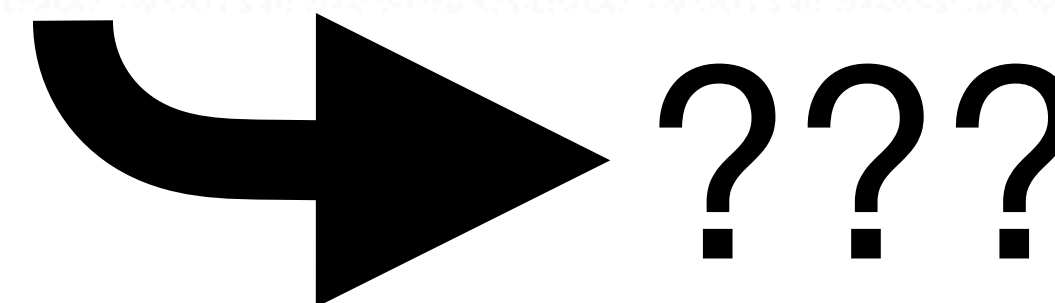

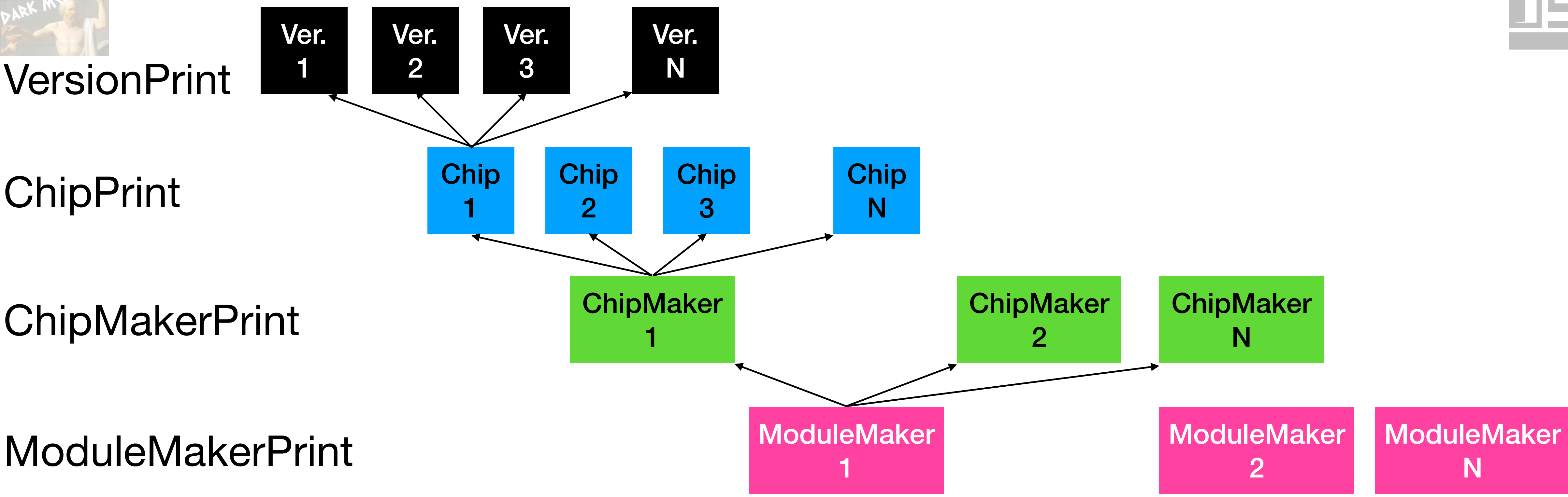

**3330** *Product Makers* registered with Bluetooth SIG as of the time of writing!

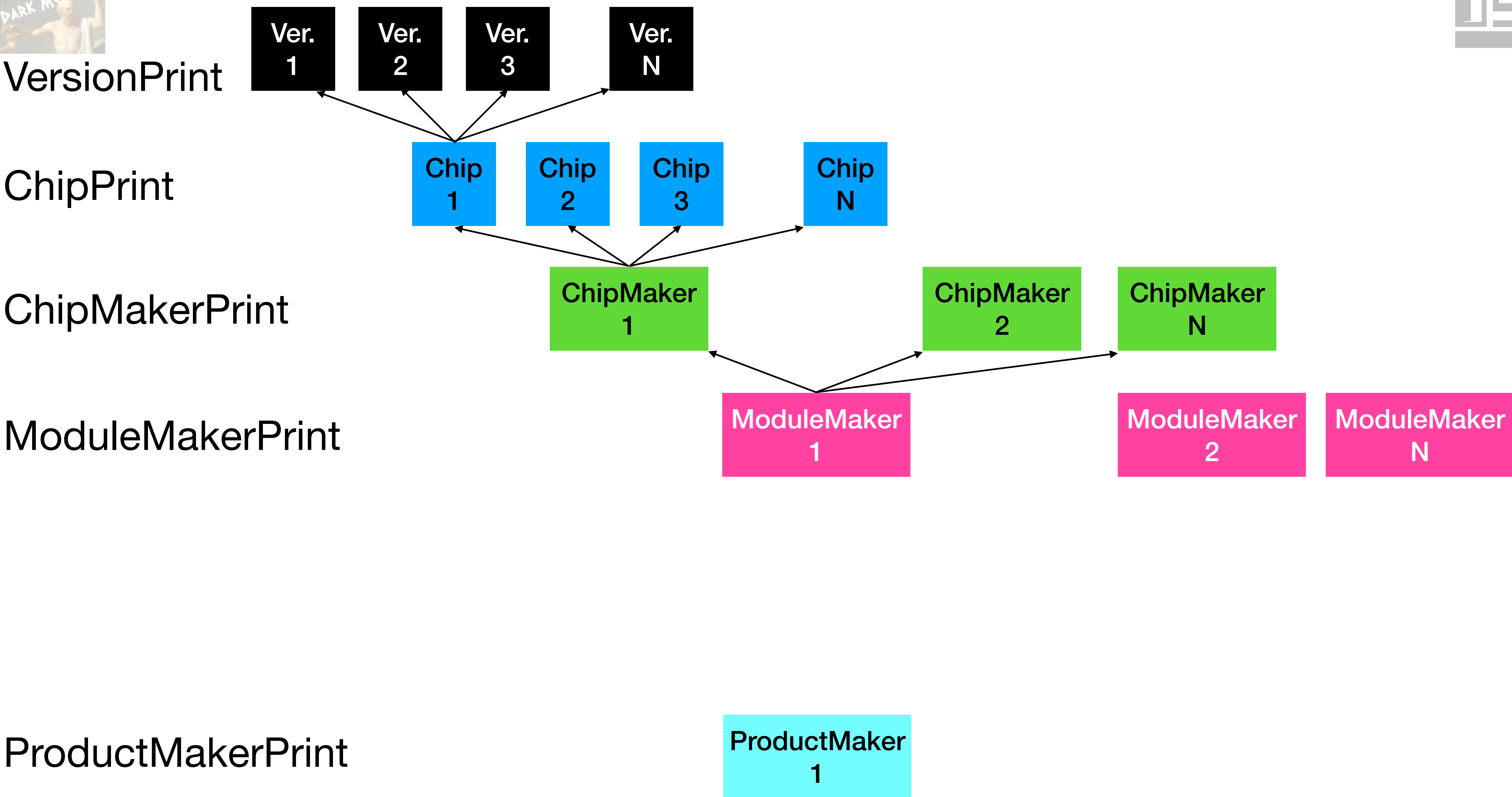

**3330 Product Makers registered with Bluetooth SIG as of the time of writing!**

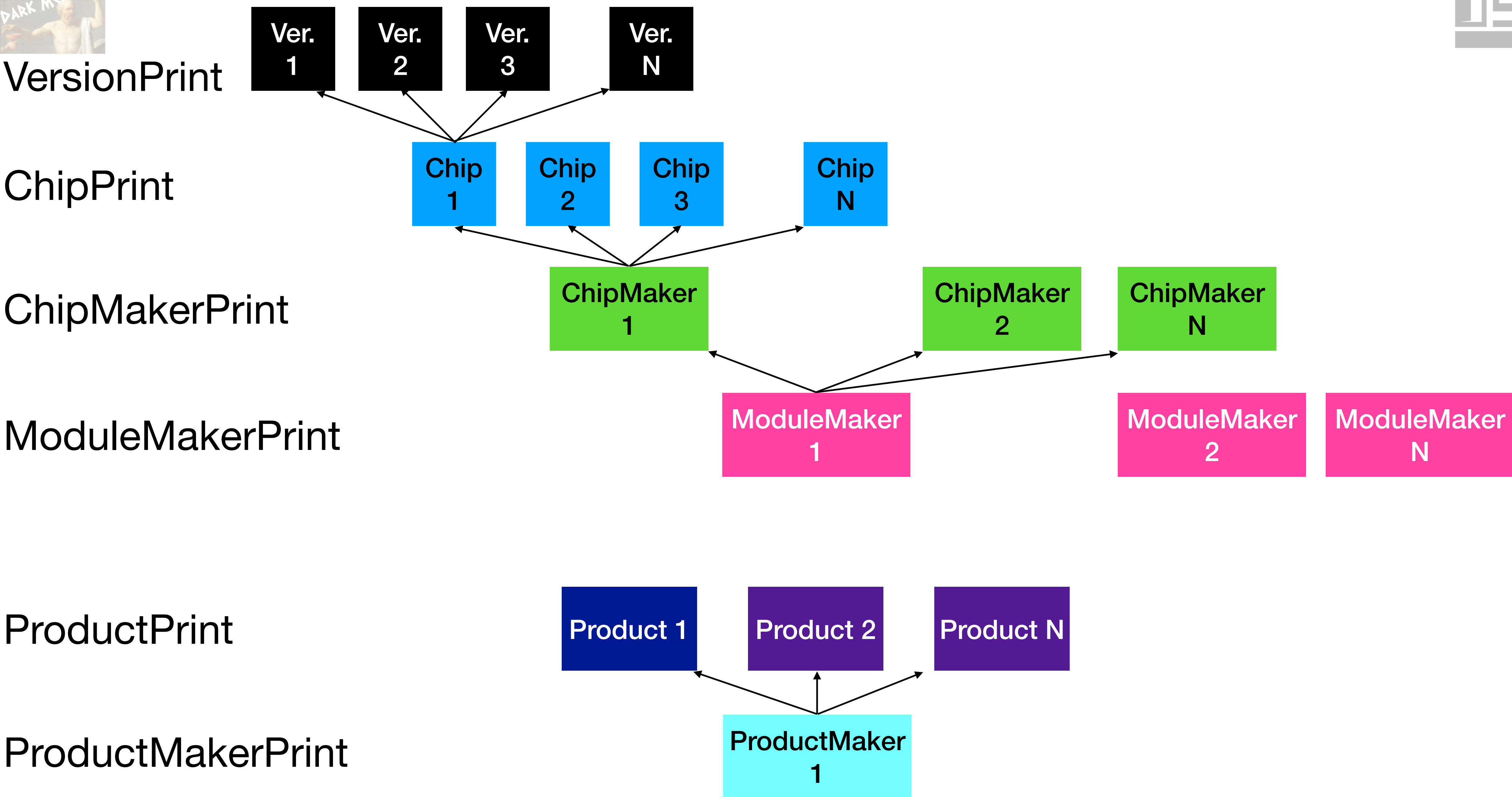

**3330 Product Makers registered with Bluetooth SIG as of the time of writing!**



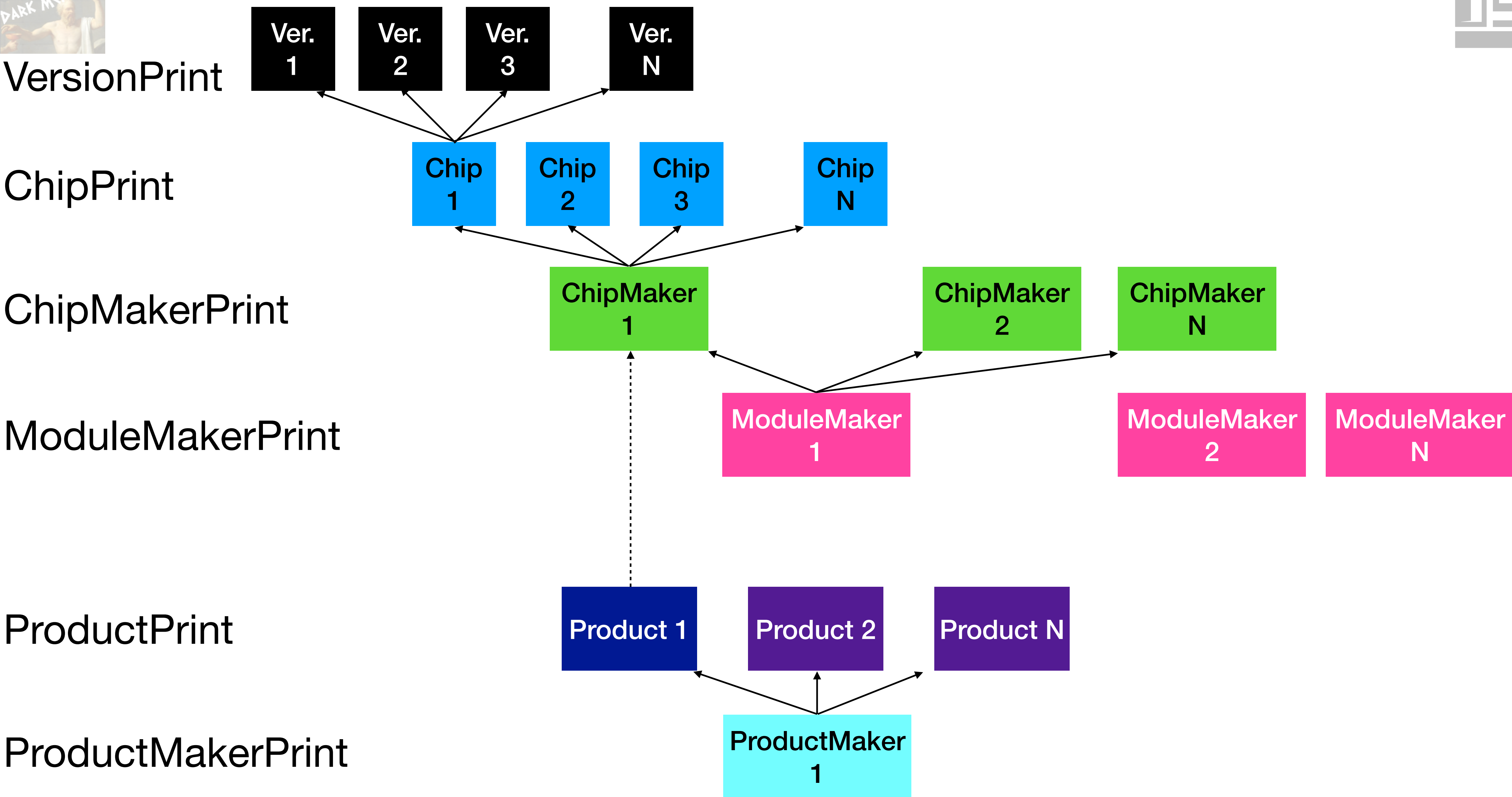

**3330 Product Makers registered with Bluetooth SIG as of the time of writing!**

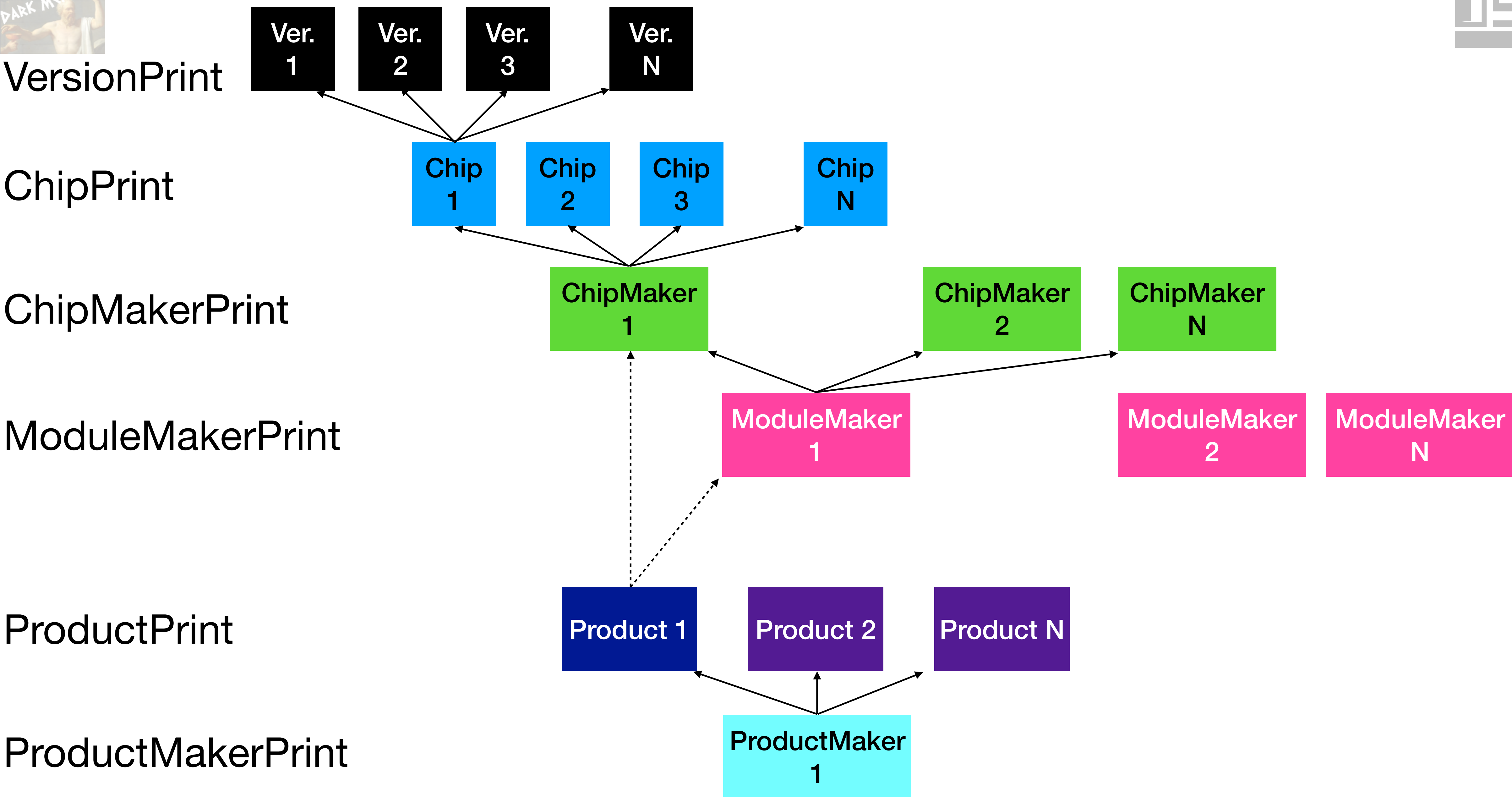

**3330 Product Makers registered with Bluetooth SIG as of the time of writing!**

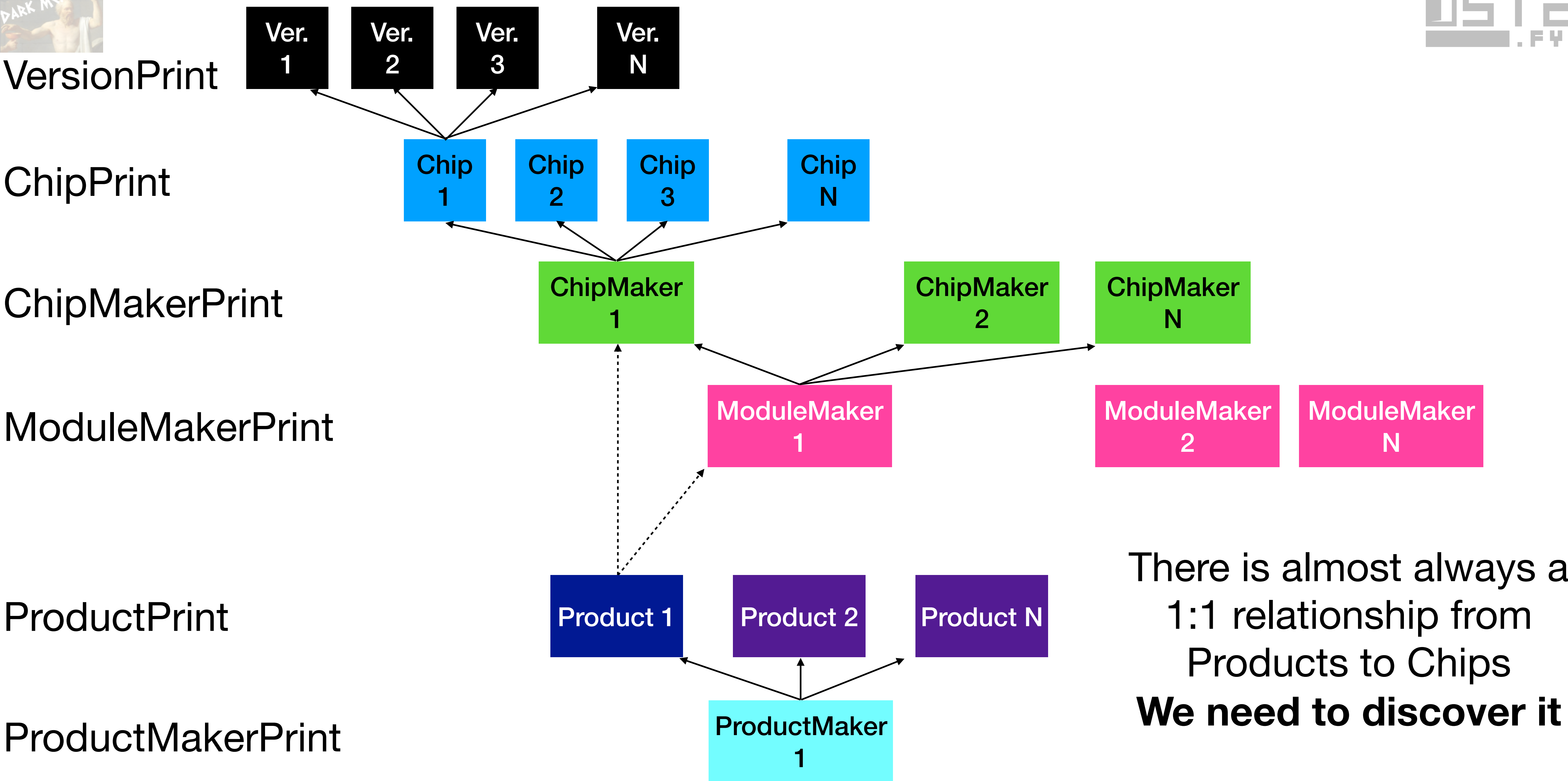

There is almost always a 1:1 relationship from Products to Chips  
**We need to discover it**

**3330 Product Makers registered with Bluetooth SIG as of the time of writing!**

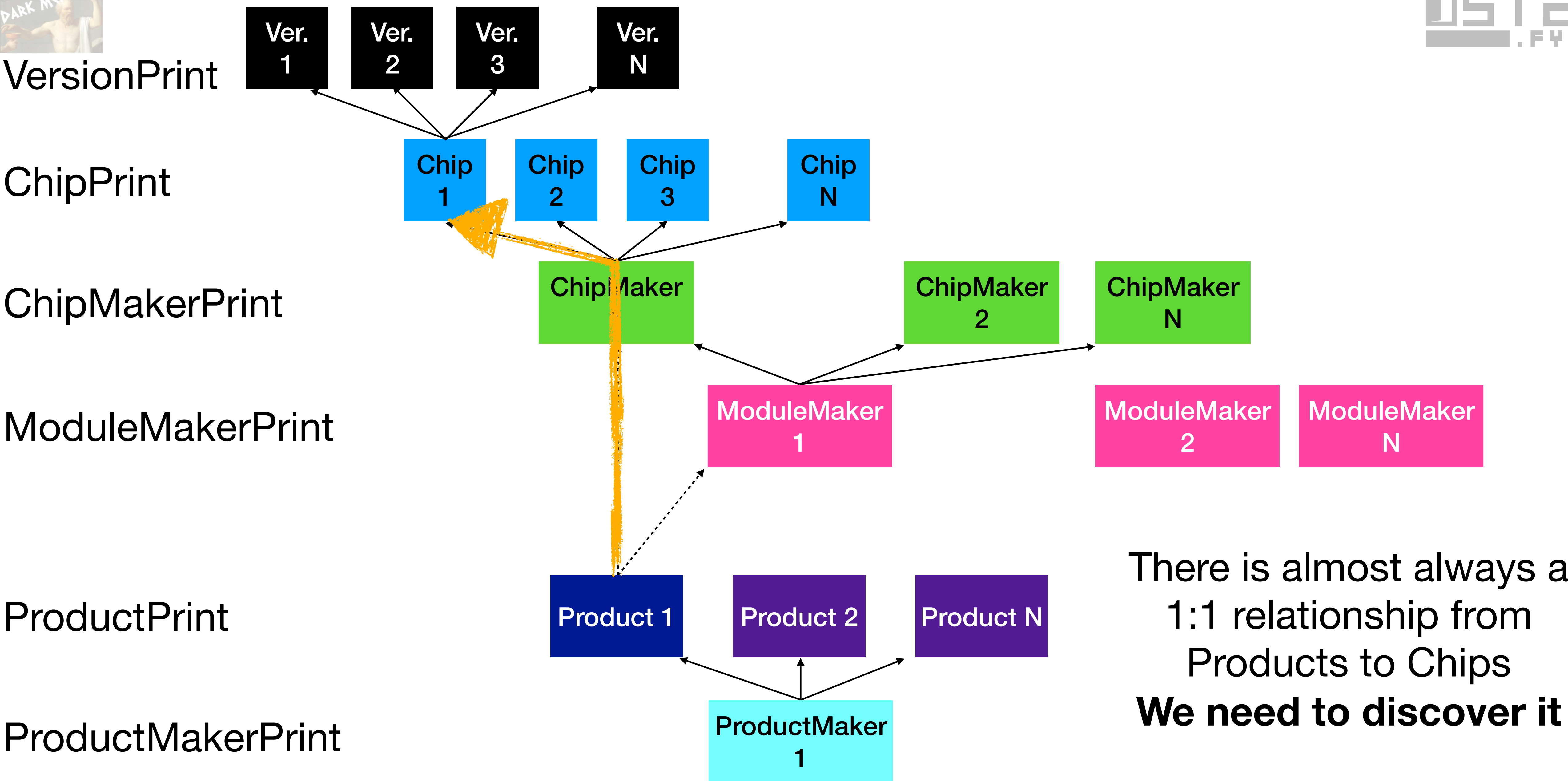

There is almost always a 1:1 relationship from Products to Chips  
**We need to discover it**

**3330 Product Makers registered with Bluetooth SIG as of the time of writing!**

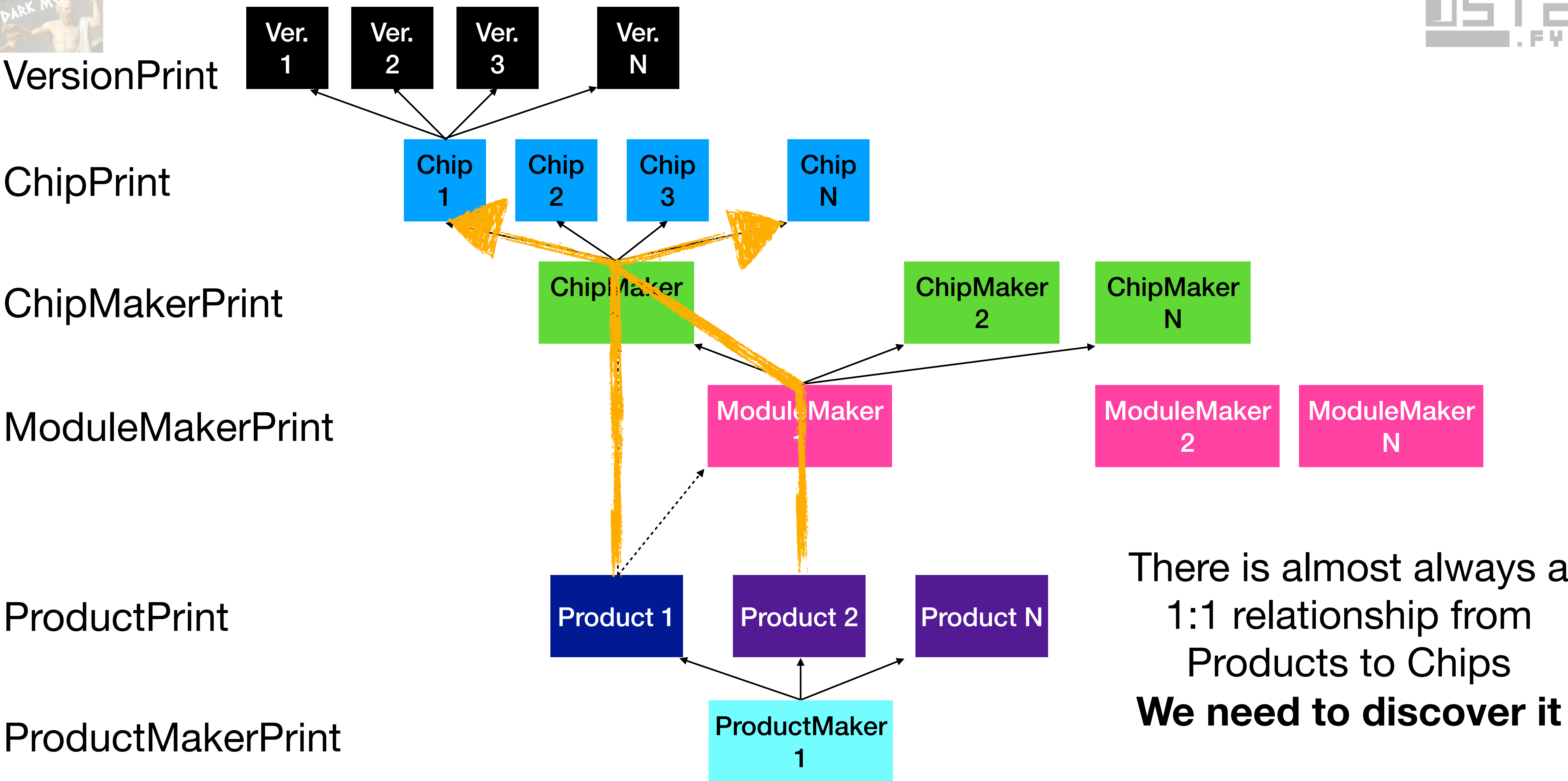

There is almost always a 1:1 relationship from Products to Chips  
**We need to discover it**

**3330** Product Makers registered with Bluetooth SIG as of the time of writing!

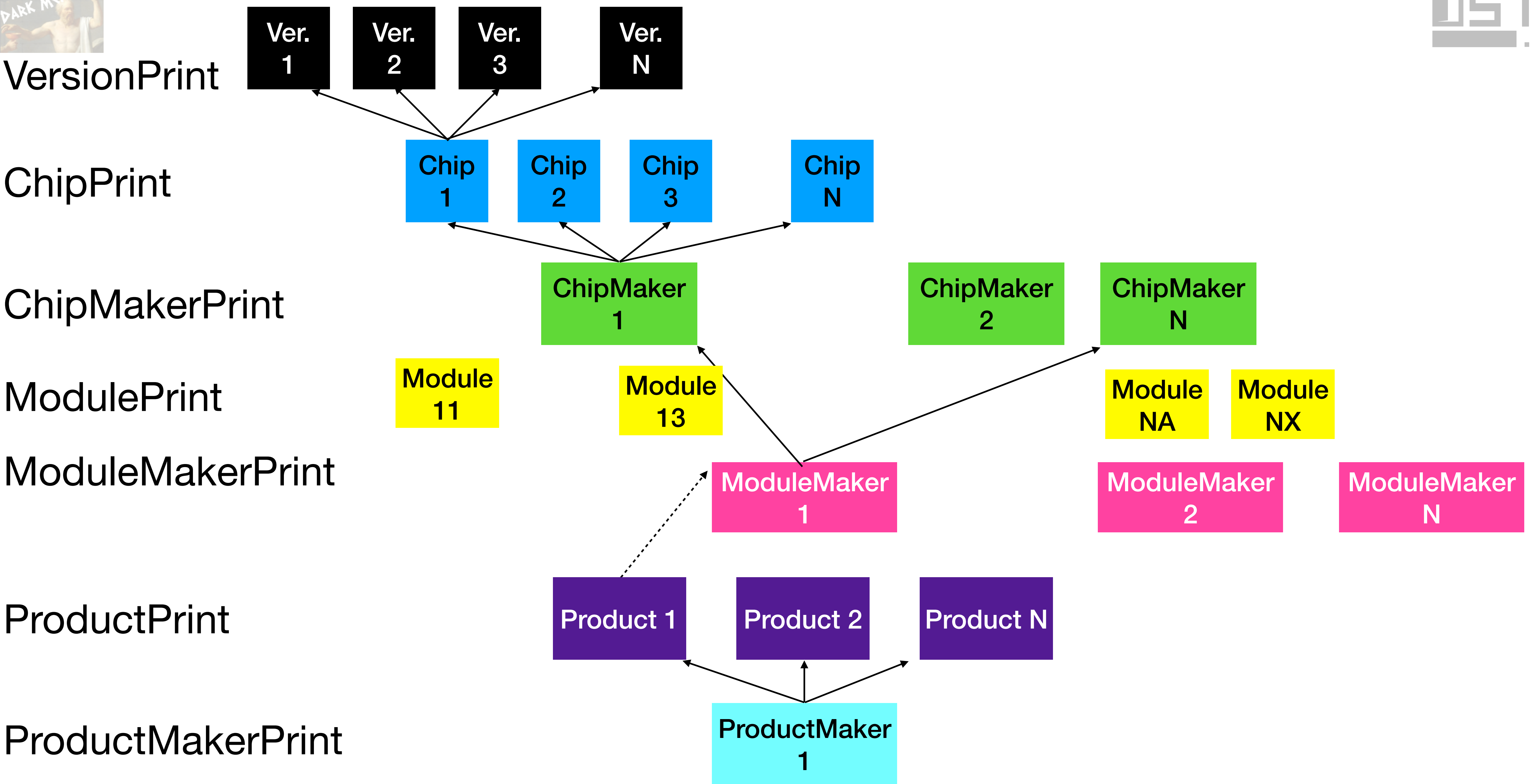

**3330 Product Makers registered with Bluetooth SIG as of the time of writing!**

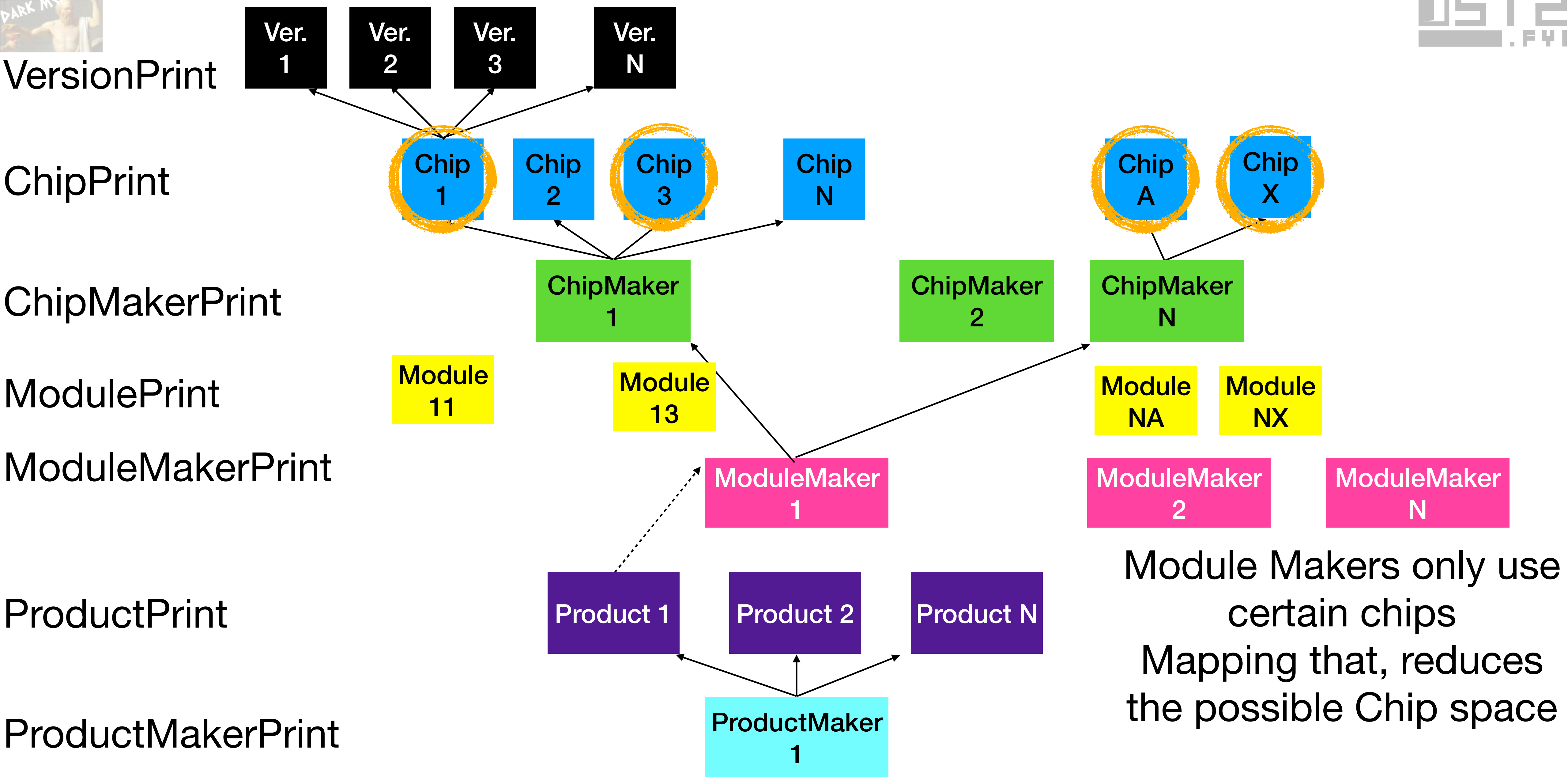

Module Makers only use certain chips  
Mapping that, reduces the possible Chip space

**3330** Product Makers registered with Bluetooth SIG as of the time of writing!



VersionPrint

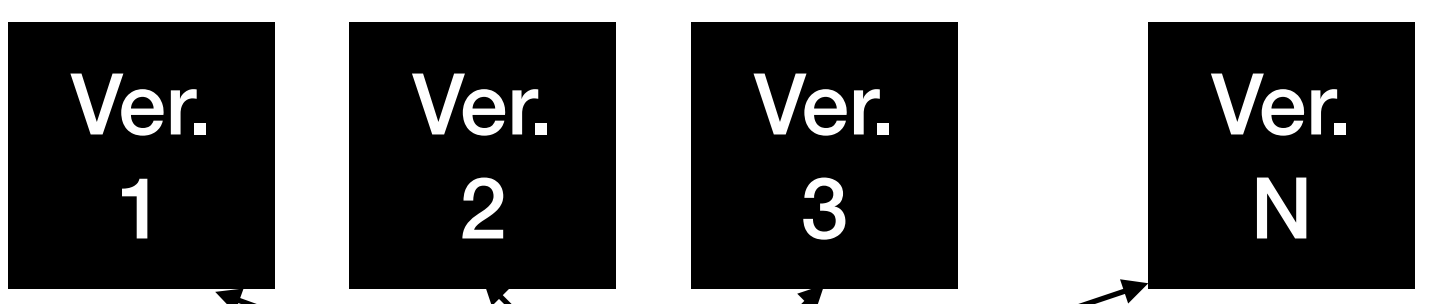

ChipPrint

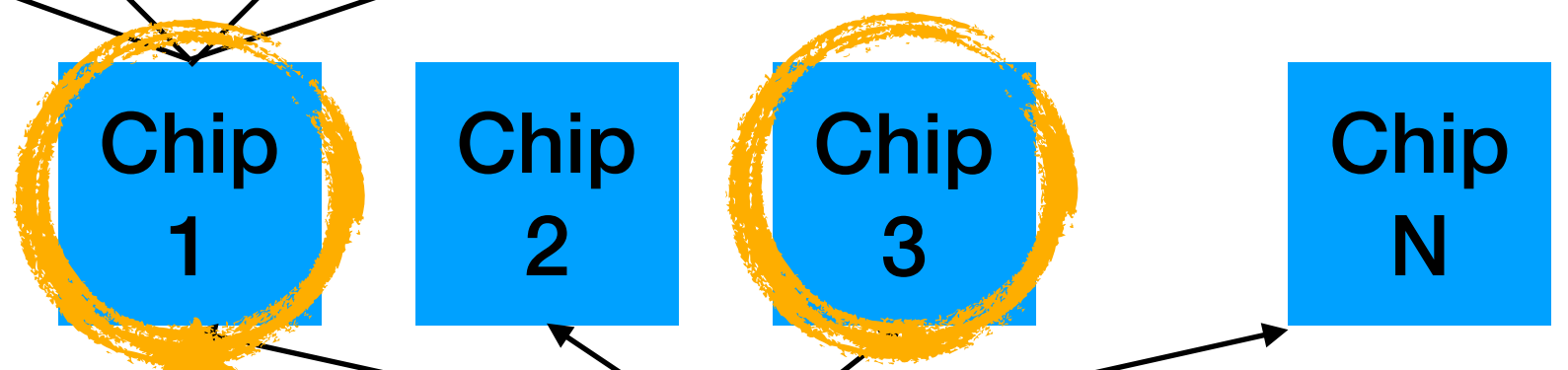

ChipMakerPrint



ModulePrint

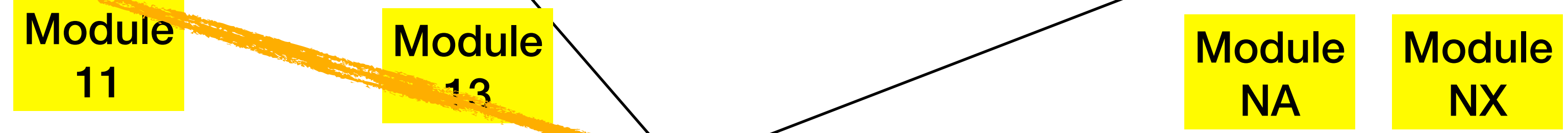

ModuleMakerPrint



ProductPrint



ProductMakerPrint

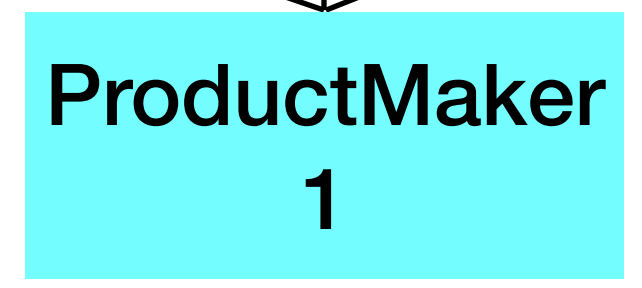

Module Makers only use certain chips  
Mapping that, reduces the possible Chip space

**3330** Product Makers registered with Bluetooth SIG as of the time of writing!



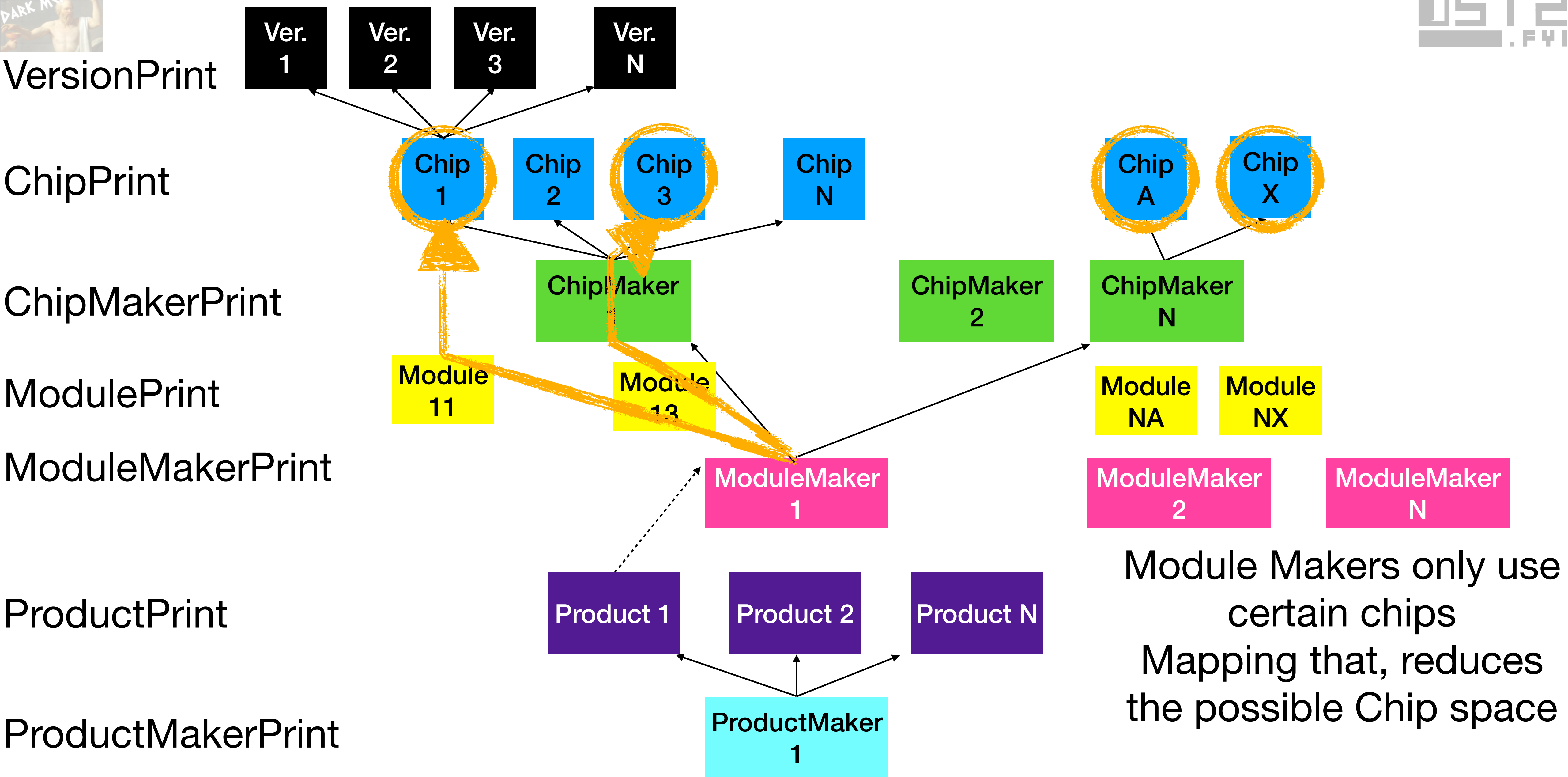

**3330 Product Makers registered with Bluetooth SIG as of the time of writing!**

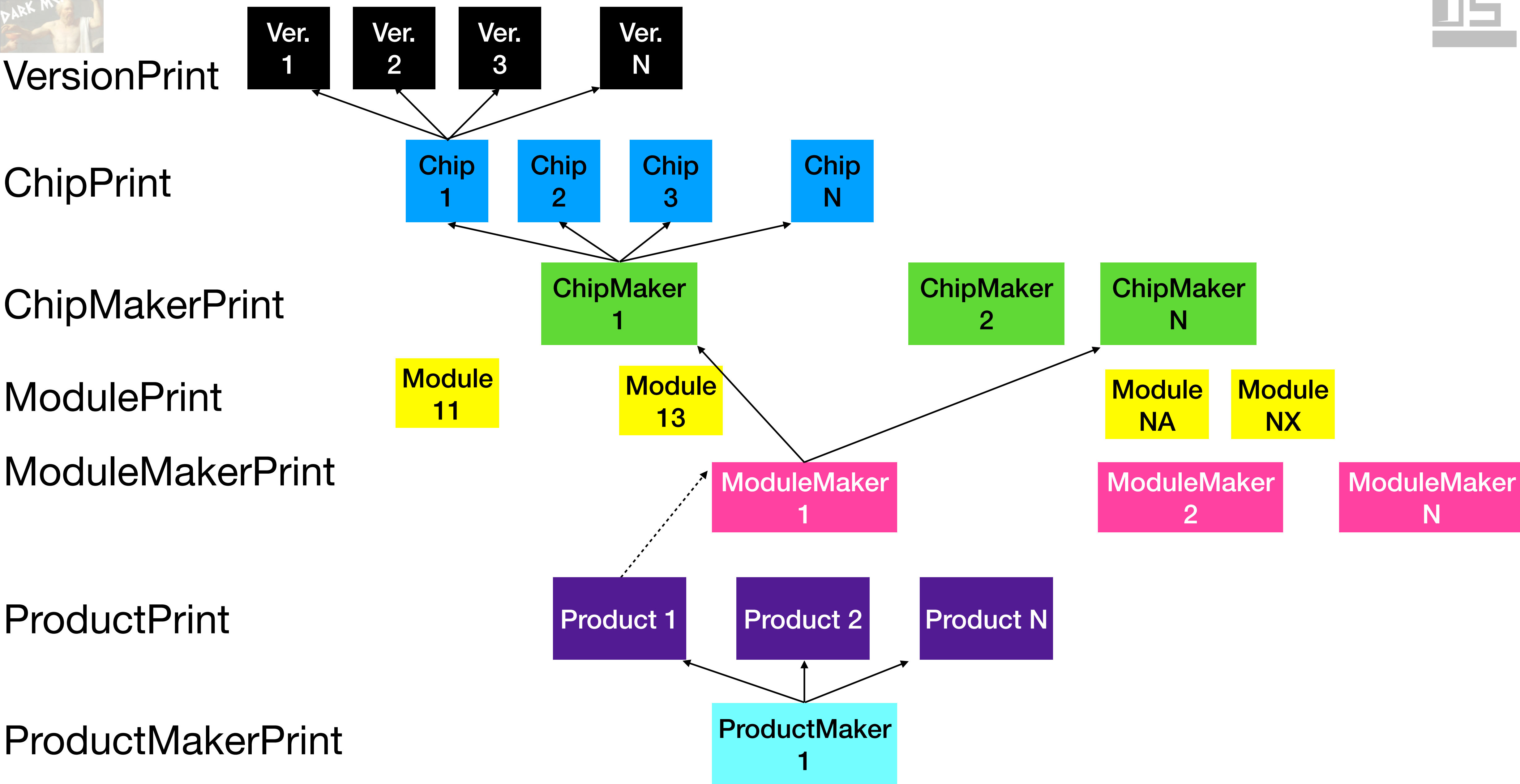

# WHAT I WANT!

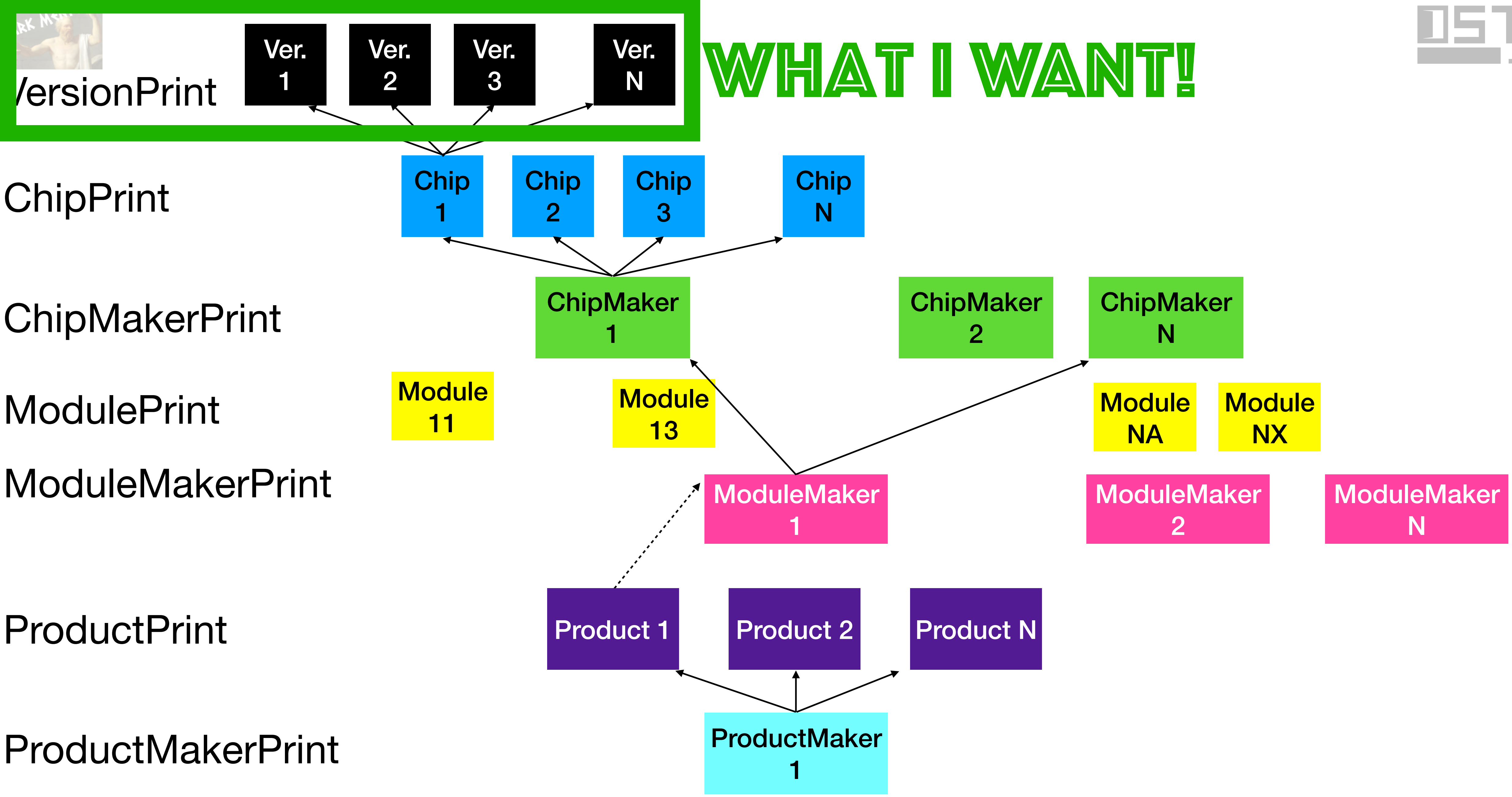

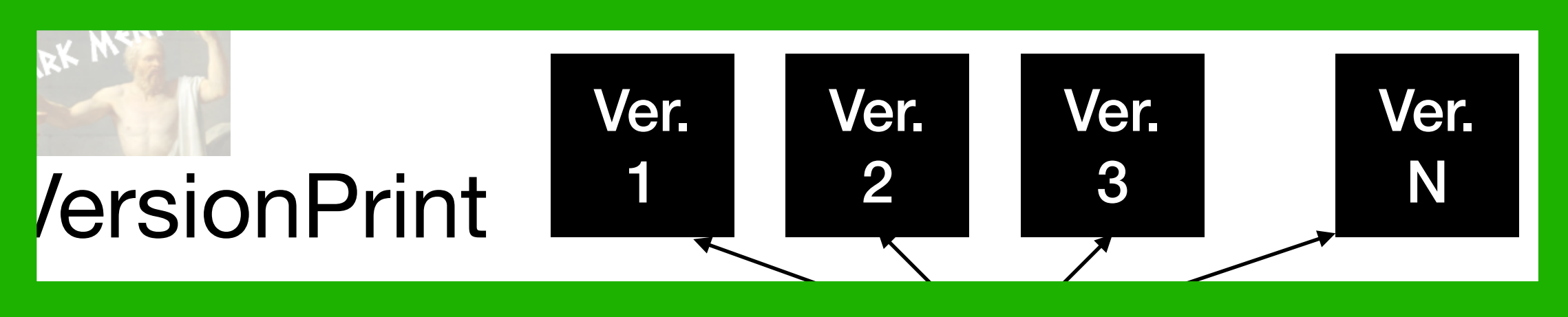

WHAT I WANT!

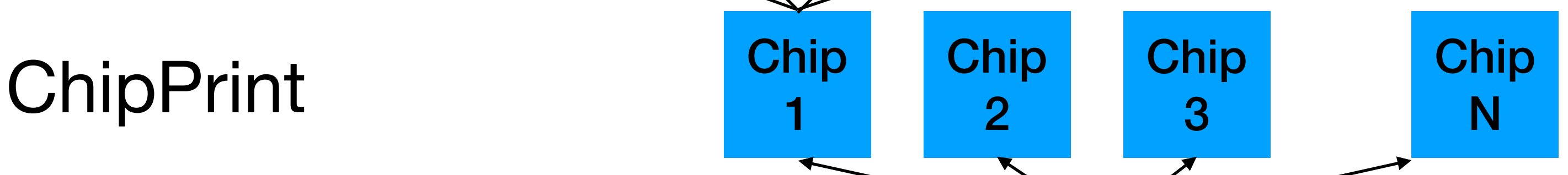

WHAT I MOSTLY GET 😞

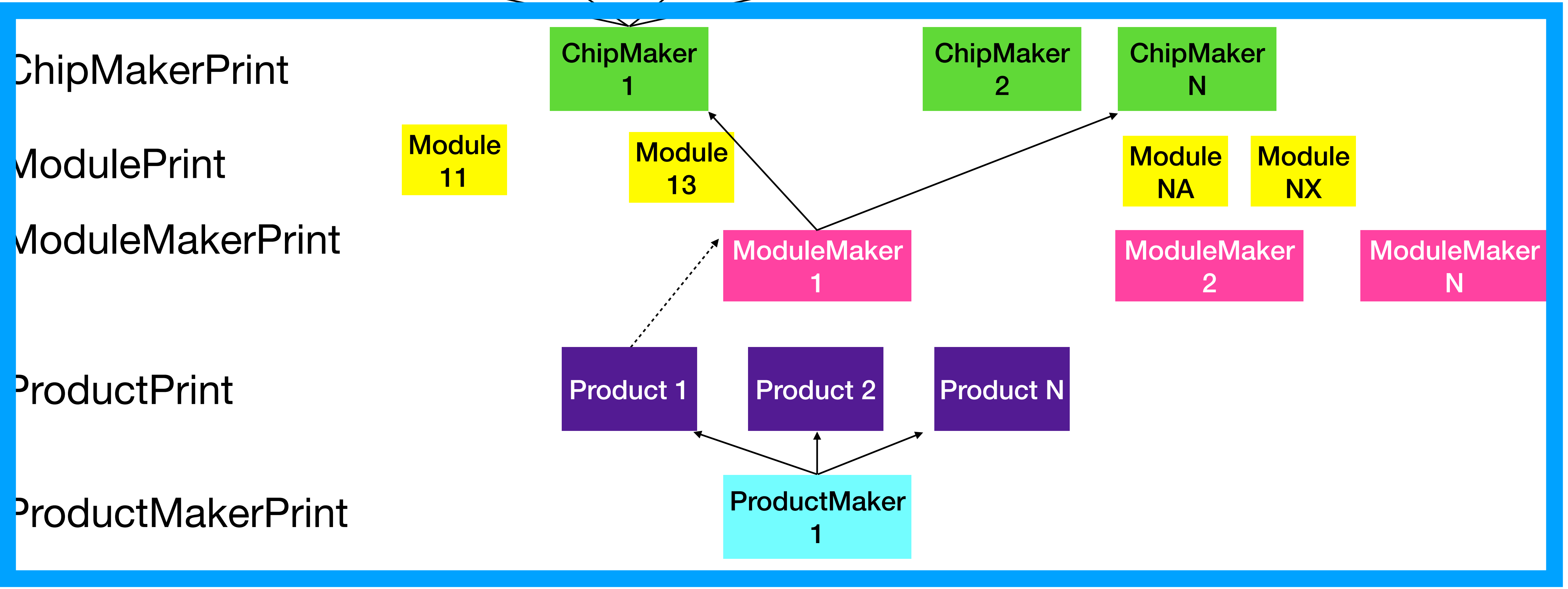



# My Terminology

- BTC = Bluetooth Classic 
- BLE = Bluetooth Low Energy
- BDADDR = Bluetooth Device Address (like MAC address)



# So you've got a couple million datapoints...

## Is any of it useful?

- I started doing basic naïve BT data collection as a hobby during the pandemic as a way to get out of the house and drive around
  - See "It was harder to sniff Bluetooth through my mask during the Pandemic" talk from summer 2023
- The majority of my data is Linux "HCI" logs
  - HCI is the Host-Controller-Interface, between Linux, and the BT chip on my logging platform (mostly Raspberry Pi Zeros or 4Bs)
- I started work on customized 2thprinting in May 2023, once I had a chance to start looking at what the HCI logs could, and couldn't, provide for 2thprinting



# Overall BDADDR Data

My data as of 2023-10-26

- 73,047 *unique* BT Classic BDADDRs
- 8,392,322 *unique* BLE BDADDRs
  - 194,151 "public" BDADDRs
  - 2,731,623 "random static" BDADDRs
  - 4,950,427 "random resolvable" BDADDRs
  - 299,244 "random non-resolvable" BDADDRs

● BLE ● Classic

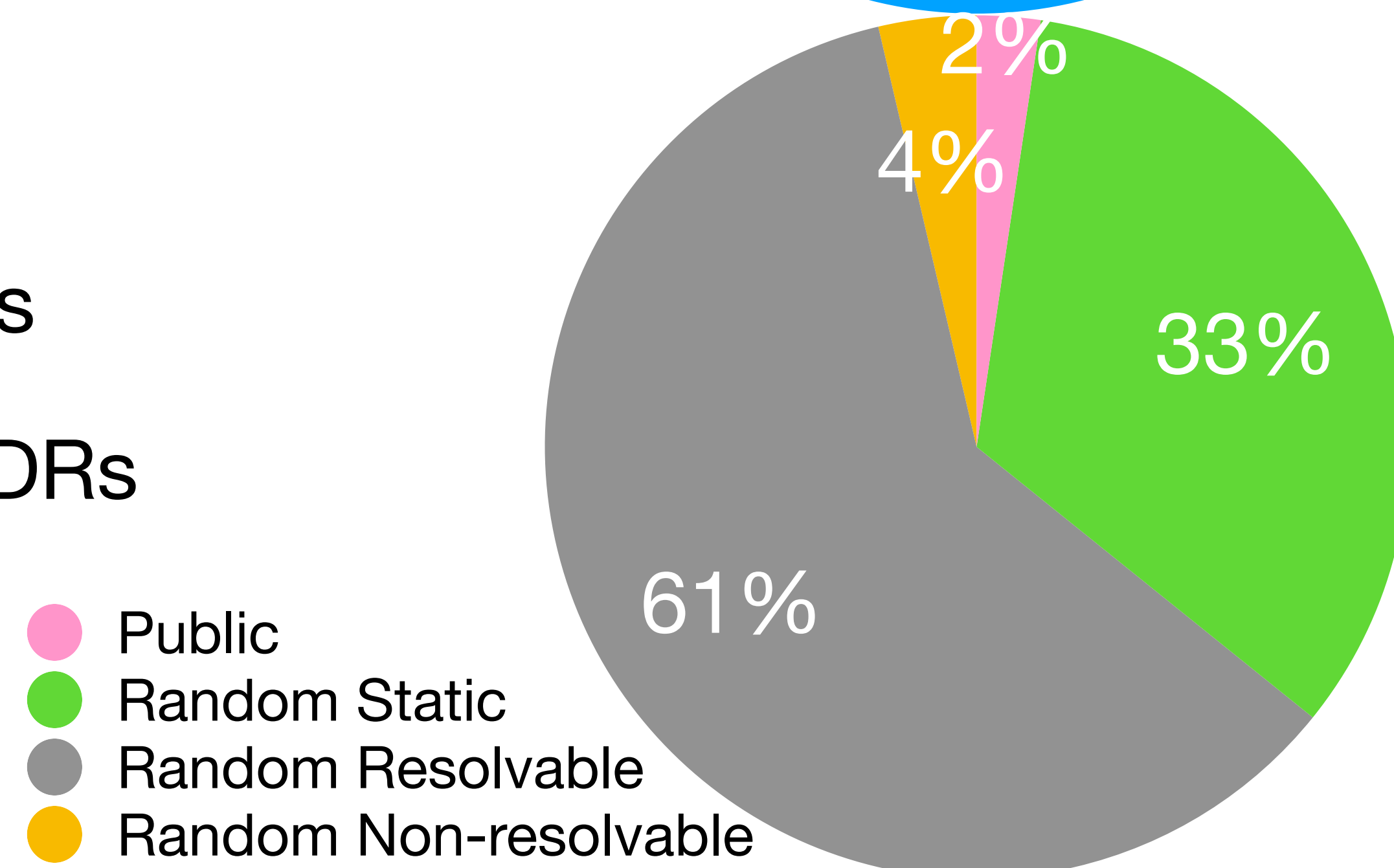
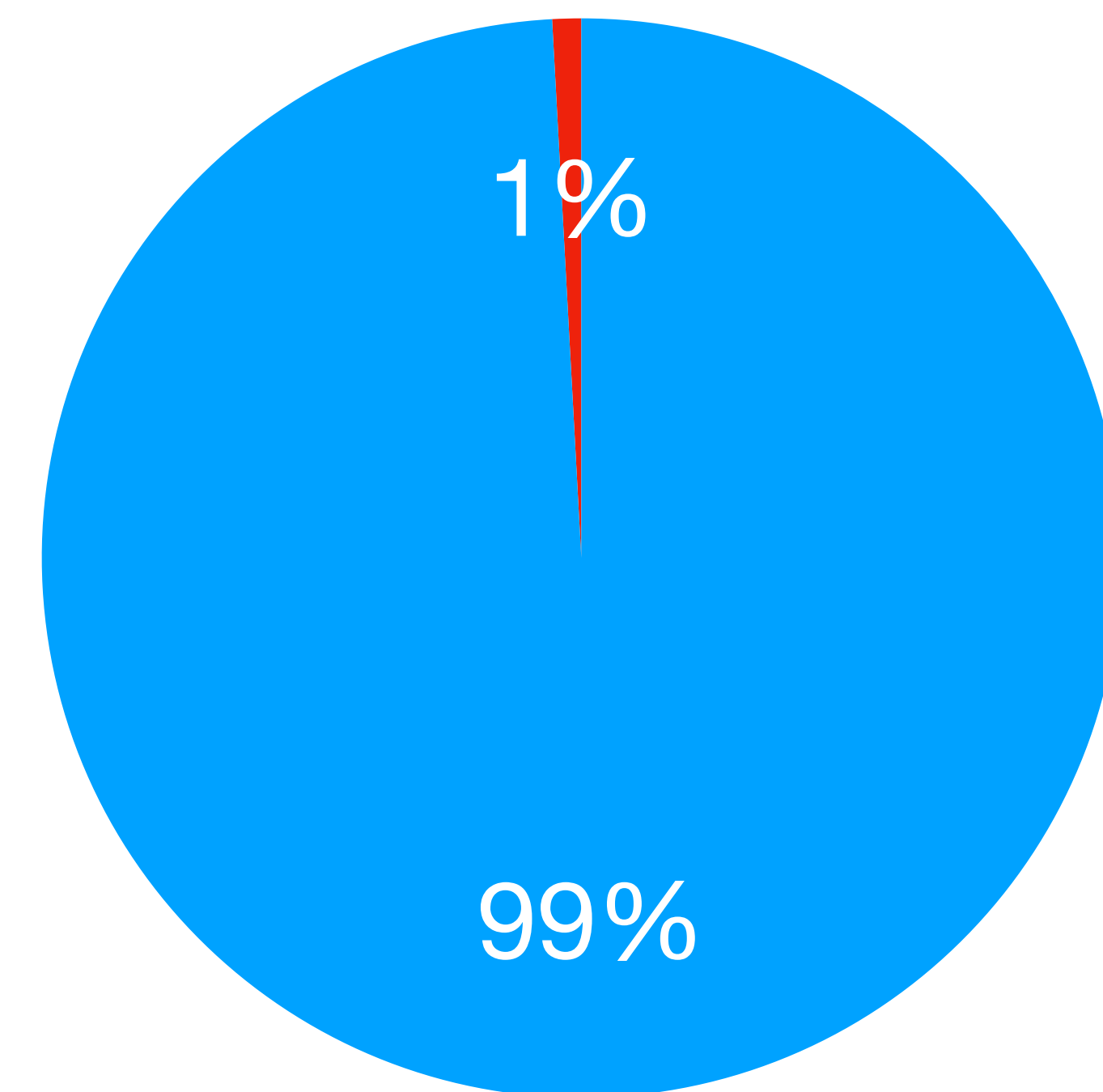



**What I Want To Know:**

**What Bluetooth Chip  
Is Inside Any Device**





**Why I Want To Know It:**

**So I Know if it's Vulnerable  
To a Firmware-Level Exploit**



# Some Possible Information Relationships

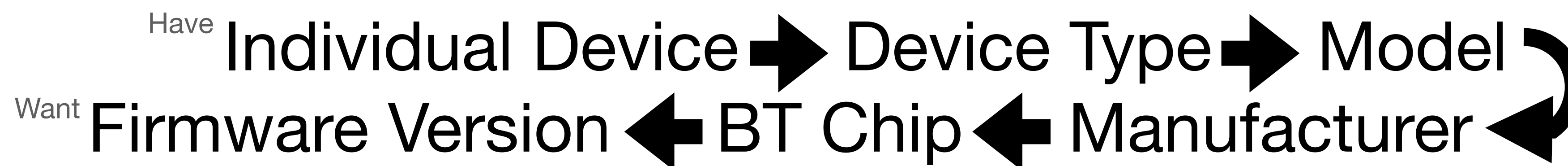



# Prior Work

## "Bluesniff - The Next Wardriving Frontier"

- [1] by Potter from 2003 "Focused on providing a UI", provided information about discoverable BTC devices

Exhibit G: Bluesniff

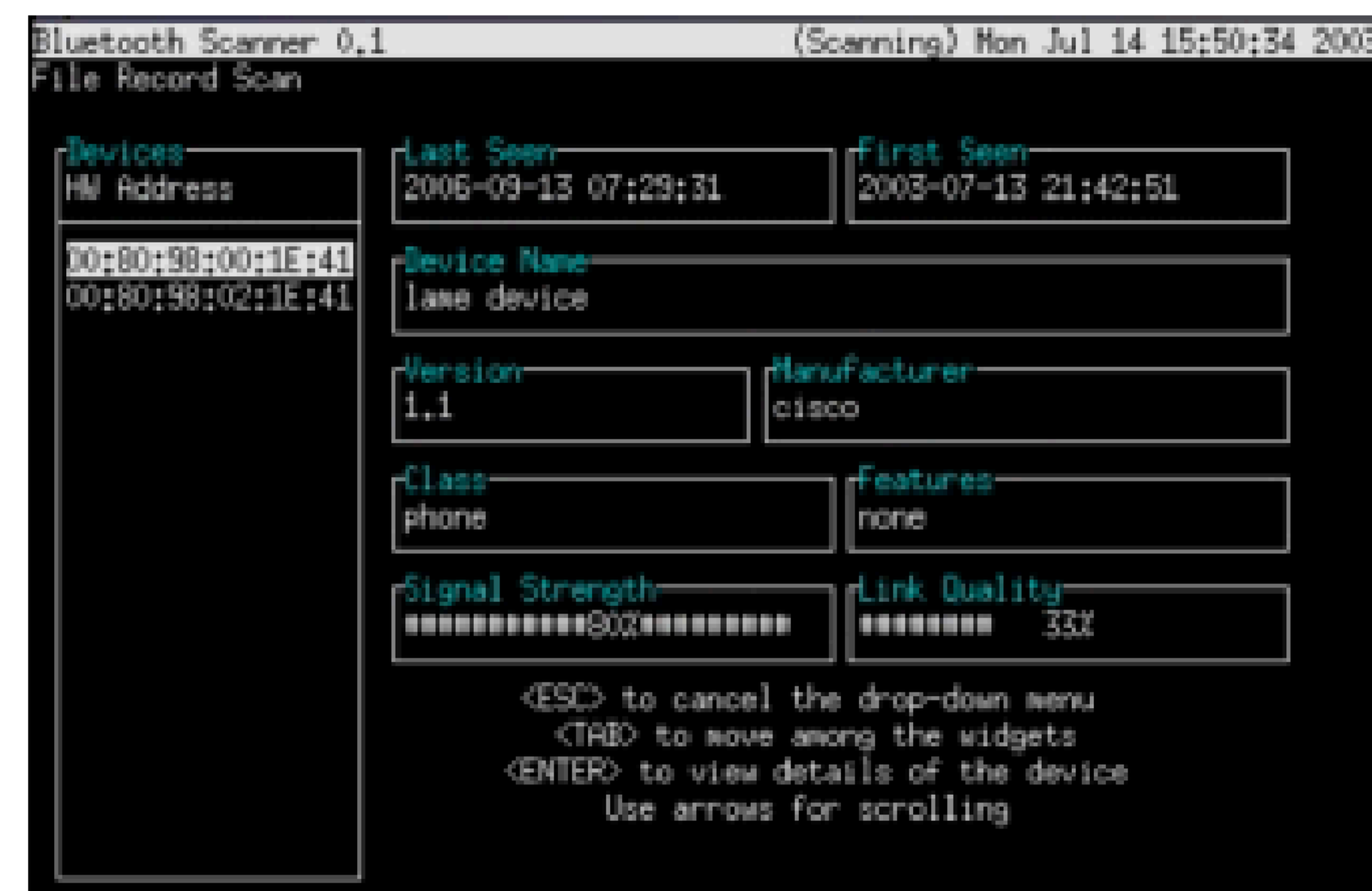

[1] <https://web.archive.org/web/20031115220513/http://www.shmoo.com/~gdead/dc-11-brucepotter.ppt>

Image from [https://web.archive.org/web/20040303230609/http://www.atstake.com/research/reports/acrobat/atstake\\_war\\_nibbling.pdf](https://web.archive.org/web/20040303230609/http://www.atstake.com/research/reports/acrobat/atstake_war_nibbling.pdf)

# Prior Work

## "Bluesniff - The Next Wardriving Frontier"

- [1] by Potter from 2003 "Focused on providing a UI", provided information about discoverable BTC devices

Exhibit G: Bluesniff

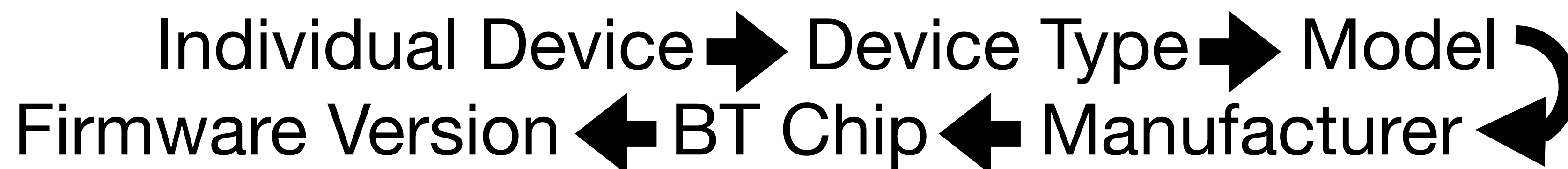
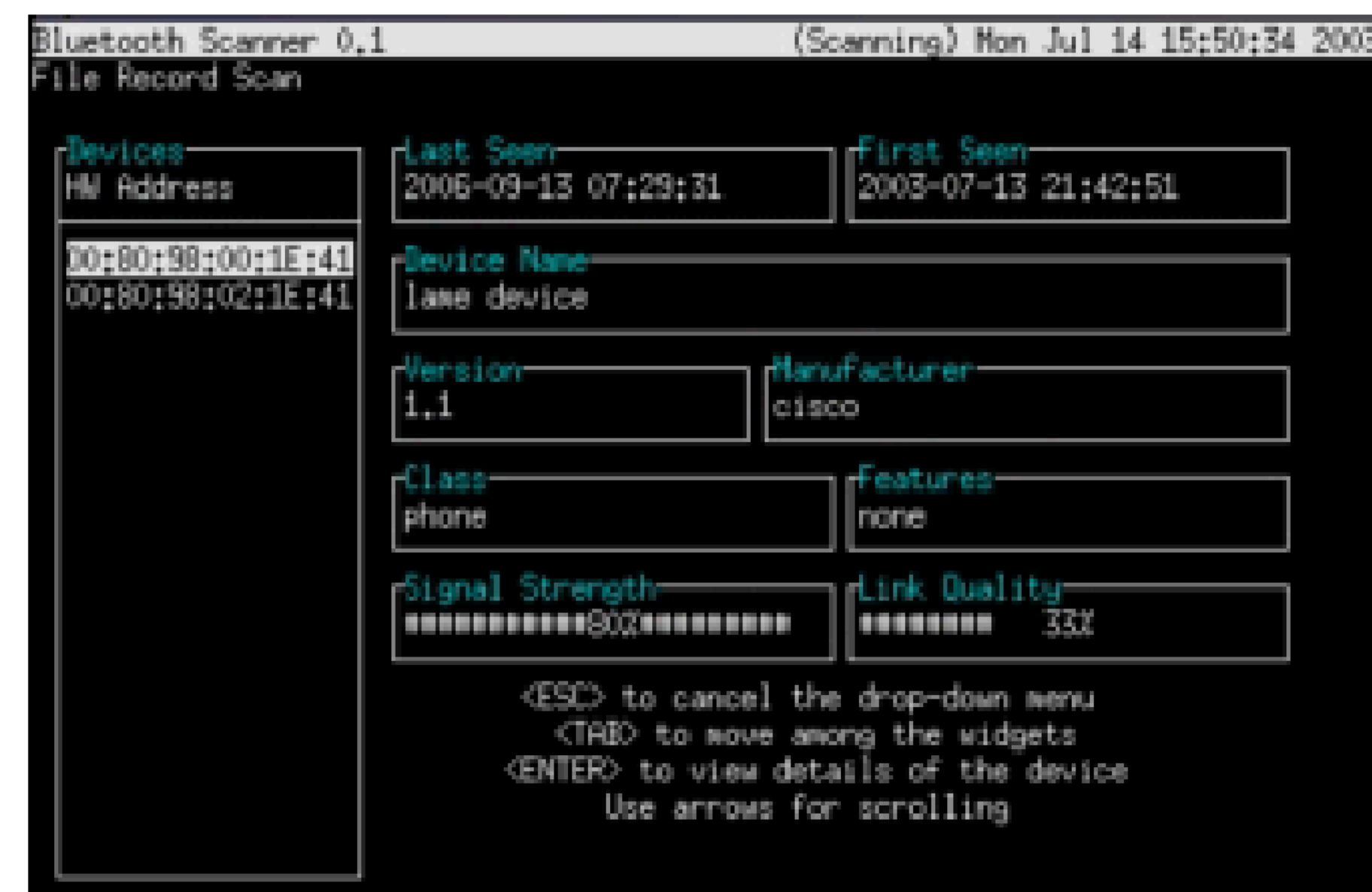

[1] <https://web.archive.org/web/20031115220513/http://www.shmoo.com/~gdead/dc-11-brucepotter.ppt>

Image from [https://web.archive.org/web/20040303230609/http://www.atstake.com/research/reports/acrobat/atstake\\_war\\_nibbling.pdf](https://web.archive.org/web/20040303230609/http://www.atstake.com/research/reports/acrobat/atstake_war_nibbling.pdf)



# Prior Work

## "Bluesniff - The Next Wardriving Frontier"

- [1] by Potter from 2003 "Focused on providing a UI", provided information about discoverable BTC devices

Exhibit G: Bluesniff

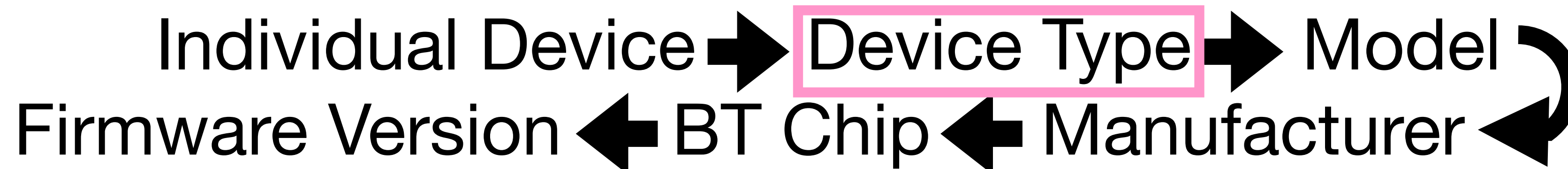
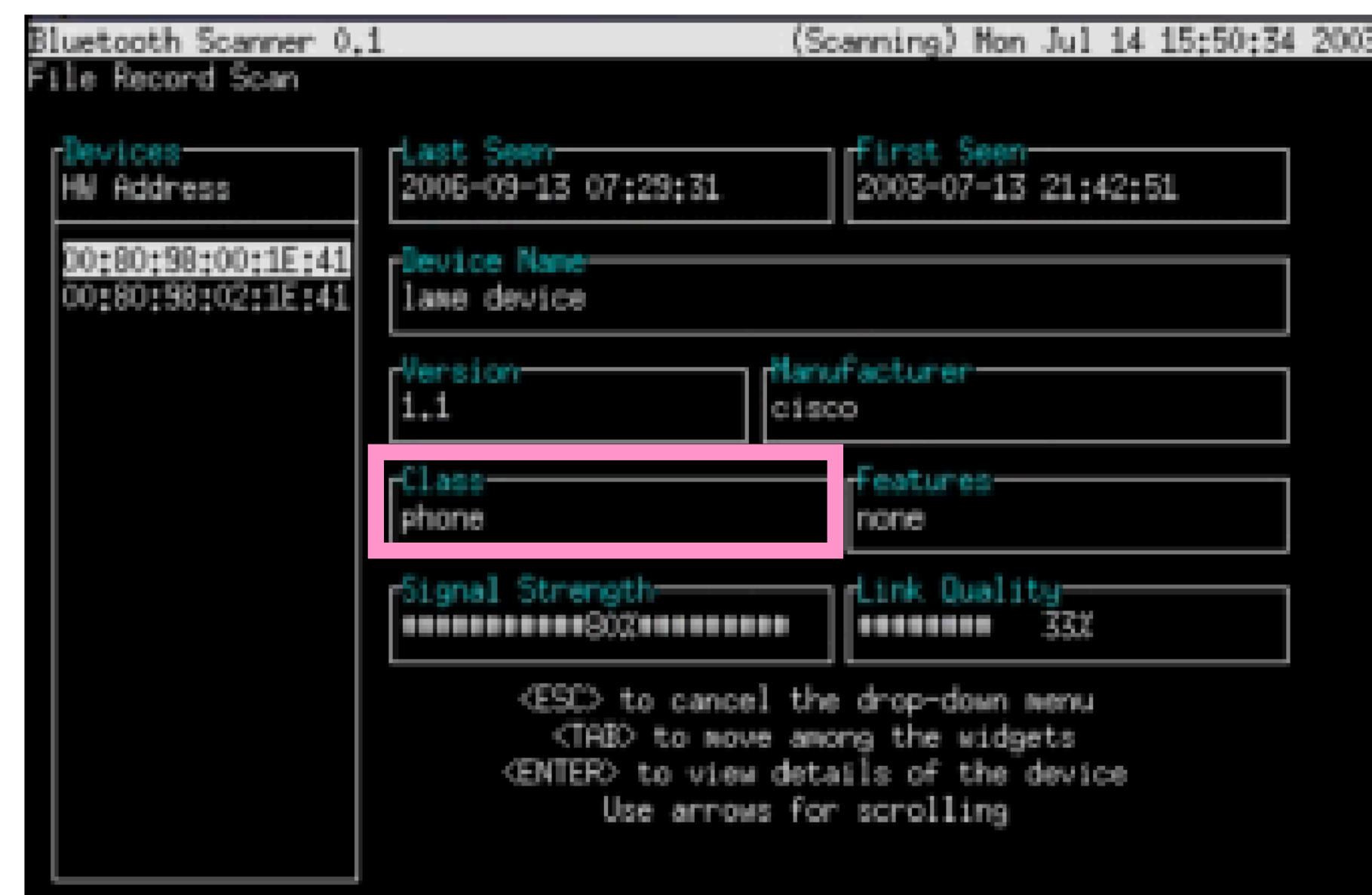

[1] <https://web.archive.org/web/20031115220513/http://www.shmoo.com/~gdead/dc-11-brucepotter.ppt>

Image from [https://web.archive.org/web/20040303230609/http://www.atstake.com/research/reports/acrobat/atstake\\_war\\_nibbling.pdf](https://web.archive.org/web/20040303230609/http://www.atstake.com/research/reports/acrobat/atstake_war_nibbling.pdf)



# Prior Work

## "Bluesniff - The Next Wardriving Frontier"

- [1] by Potter from 2003 "Focused on providing a UI", provided information about discoverable BTC devices

Exhibit G: Bluesniff

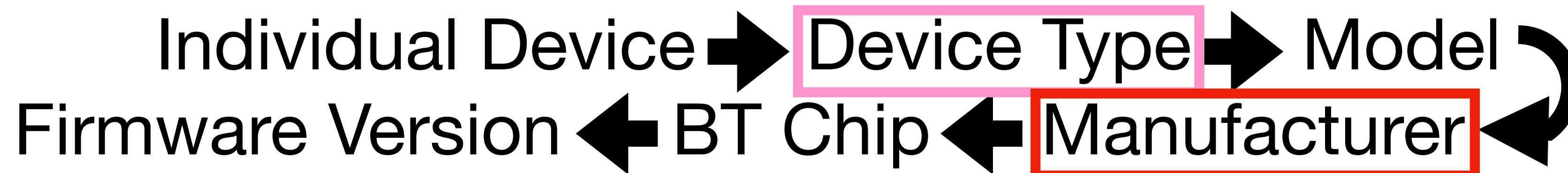
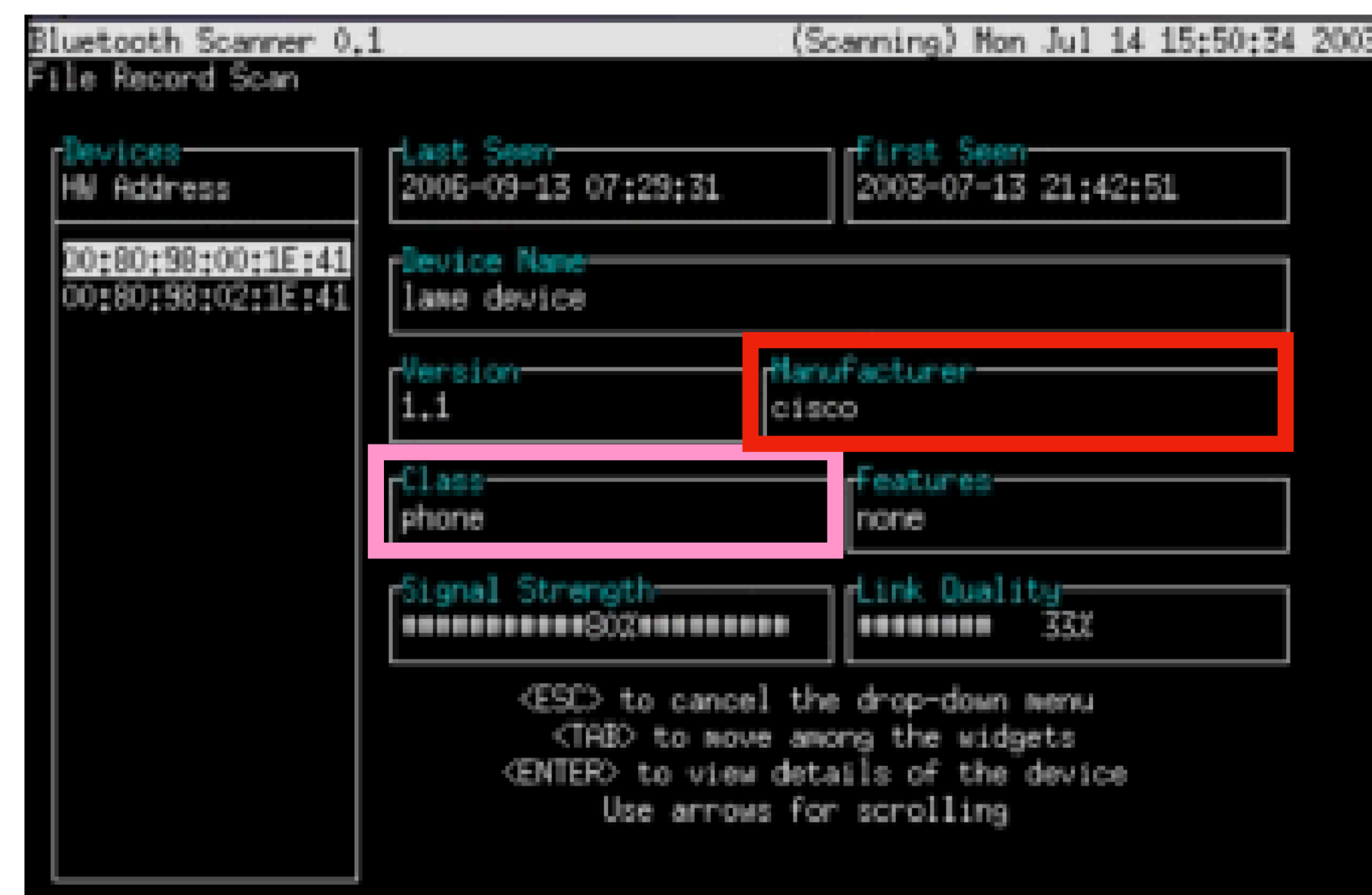

[1] <https://web.archive.org/web/20031115220513/http://www.shmoo.com/~gdead/dc-11-brucepotter.ppt>

Image from [https://web.archive.org/web/20040303230609/http://www.atstake.com/research/reports/acrobat/atstake\\_war\\_nibbling.pdf](https://web.archive.org/web/20040303230609/http://www.atstake.com/research/reports/acrobat/atstake_war_nibbling.pdf)

# Prior Work

## "BlueID: A Practical System for Bluetooth Device Identification"

- [1] by Jun Huang et al. from 2014 is focused on identifying individual devices, within a collection of potentially address-randomizing devices, based on clock skew over time

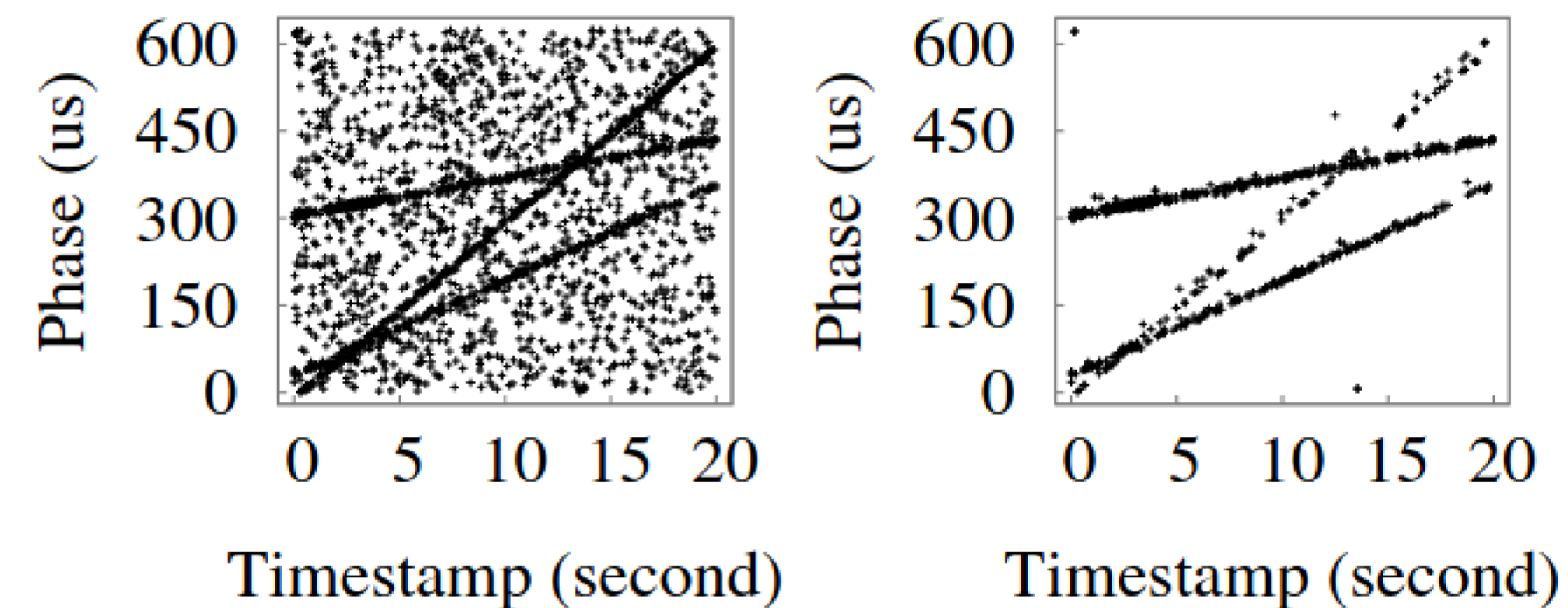

(a) Before noise filtering. (b) After noise filtering.

Fig. 2. Effect of noise filtering on Bluetooth preamble detections.

# Prior Work

## "BlueID: A Practical System for Bluetooth Device Identification"

- [1] by Jun Huang et al. from 2014 is focused on identifying individual devices, within a collection of potentially address-randomizing devices, based on clock skew over time

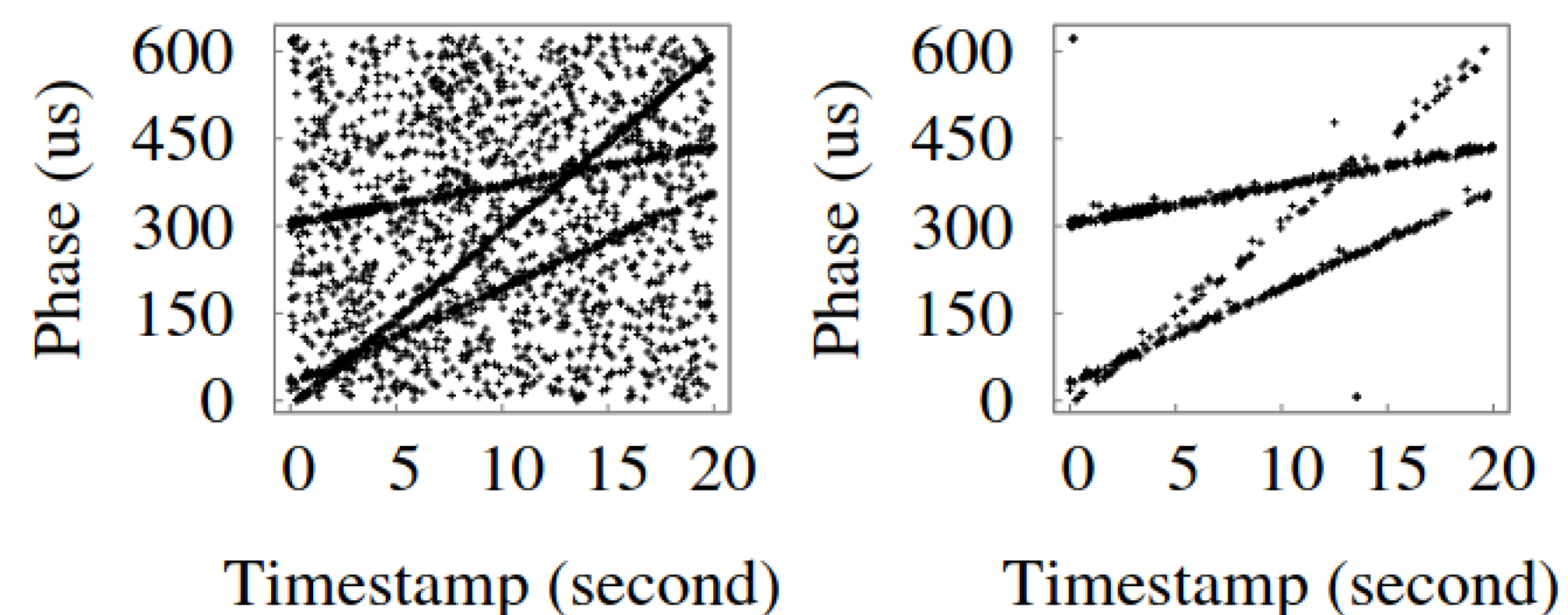

(a) Before noise filtering. (b) After noise filtering.

Fig. 2. Effect of noise filtering on Bluetooth preamble detections.

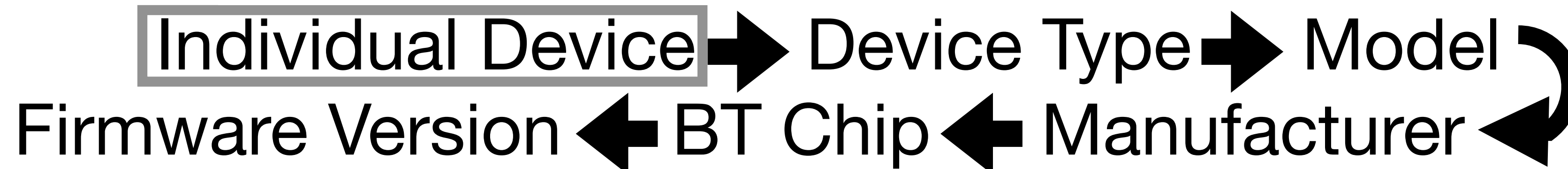





# Prior Work

## Only mentioning for completeness

- "Bluetooth devices fingerprinting using low cost SDR"[1]
- "Bluetooth Low Energy Device Identification Based on Link Layer Broadcast Packet Fingerprinting" [2]
  - Both test so few devices as to be meaningless
    - [2] "An experimental result on a dataset with 15 types of BLE devices"



# Prior Work

## Only mentioning for completeness

- "Bluetooth devices fingerprinting using low cost SDR"[1]
- "Bluetooth Low Energy Device Identification Based on Link Layer Broadcast Packet Fingerprinting" [2]
  - Both test so few devices as to be meaningless
    - [2] "An experimental result on a dataset with 15 types of BLE devices"

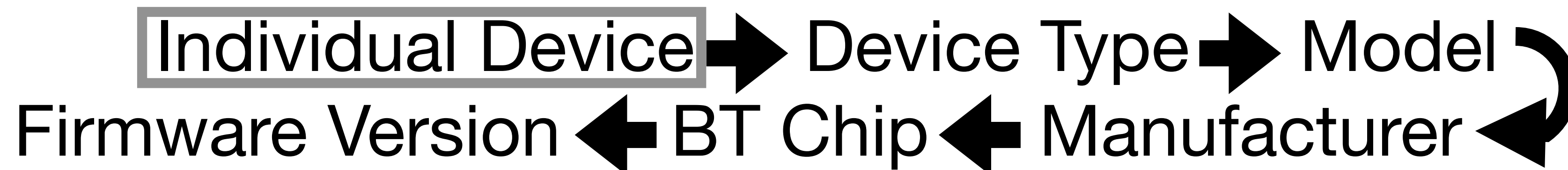



## Bluetooth Security Timeline



1st November 2023 at 12:09am

Submit additions or corrections via Merge Requests at [https://gitlab.com/XenoKovah/bluetooth\\_security\\_timeline](https://gitlab.com/XenoKovah/bluetooth_security_timeline)

Read this [Contributor Guidance](#) before sending Merge Requests

Key:

= High Impact!

= PoC exploit available

= Tool

### 2023

#### 11

[Blue2thprinting \(blue-\[tooth\)-printing\]: answering the question of 'WTF am I even looking at?!](#)

#### 10

[Open Wounds: The last 5 years have left Bluetooth to bleed](#)

#### 08

[Snoop on to them as they snoop on to us](#)

## Bluetooth Security Timeline

By [@XenoKovah](#) of [@DarkMentorLLC](#)



🔍 ✕ ▾ 15 matches

*Title matches:*

- A PSD-based fingerprinting approach to detect IoT device spoofing
- An overview of bluetooth device discovery and fingerprinting techniques – assessing the local context
- Automatic Fingerprinting of Vulnerable BLE IoT Devices with Static UUIDs from Mobile Apps
- Blueprinting - Remote Device Identification based on Bluetooth Fingerprinting Techniques
- Fingerprinting and analysis of Bluetooth devices with automata learning
- Fingerprinting Bluetooth-Low-Energy Devices Based on the Generic Attribute Profile
- Reverse Engineering Apple's BLE Continuity Protocol for Tracking, OS Fingerprinting, and Behavioral Profiling
- Tech: Fingerprinting

*All matches:*

- A PSD-based fingerprinting approach to detect IoT device spoofing
- An overview of bluetooth device discovery and fingerprinting techniques – assessing the local context
- Automatic Fingerprinting of Vulnerable BLE IoT Devices with Static UUIDs from Mobile Apps
- Blue2thprinting (blue-[tooth)-printing]: answering the question of 'WTF am I even looking at?!
- BlueID: A Practical System for Bluetooth Device Identification
- Blueprinting - Remote Device Identification based on Bluetooth Fingerprinting Techniques
- Bluetooth Security Timeline
- Evaluating Physical-Layer BLE Location Tracking Attacks on Mobile Devices
- Every Byte Matters: Traffic Analysis of Bluetooth Wearable Devices
- Fingerprinting and analysis of Bluetooth devices with automata learning
- Fingerprinting Bluetooth-Low-Energy Devices Based on the Generic Attribute Profile
- It Was Harder to Sniff Bluetooth Through My Mask During the Pandemic...
- Mass-pwning with a small IoT spy bug
- Reverse Engineering Apple's BLE Continuity Protocol for Tracking, OS Fingerprinting, and Behavioral Profiling
- Tech: Fingerprinting



# Prior Work - What I Get

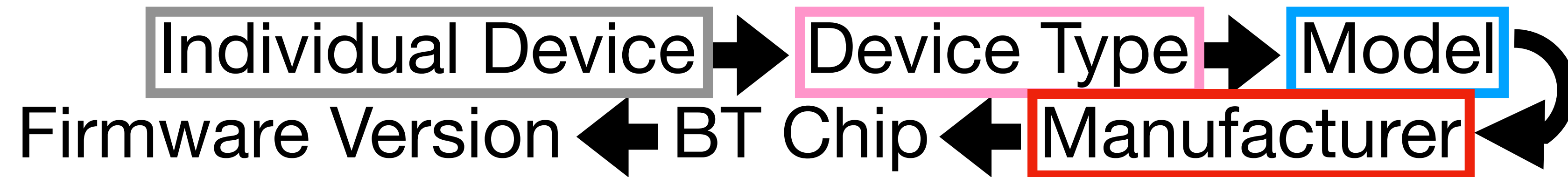



# What I Want

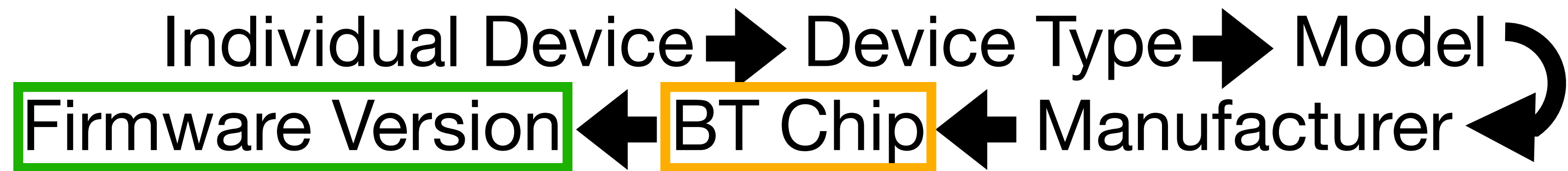



 Passive

# 2thprinting Approaches

 Mostly-Passive

 Active

# Bluetooth: The Gathering: 🧘 Passive

- Run a sniffer, never send *any* packets
- **BLE:** Sniffle, Ice9 Sniffer, **BTC:** Ubertooth
- BLE ADV\_IND, NONCONN\_ADV\_IND



# Bluetooth: The Gathering: 🧑 *Mostly-Passive*

- Ask your OS "What Bluetooth devices are currently visible?"
- It will scan for any advertisements, and *potentially*, autonomously, query some limited information about devices it finds, such as device name, class of device, etc (depends on OS & Bluetooth stack version)
- This is most of my data





# Bluetooth: The Gathering: 🏀 Active

- Send custom BLE LL / BTC LMP packets (requires custom controller firmware)
- Connect to all connectable interfaces, query all queryable information

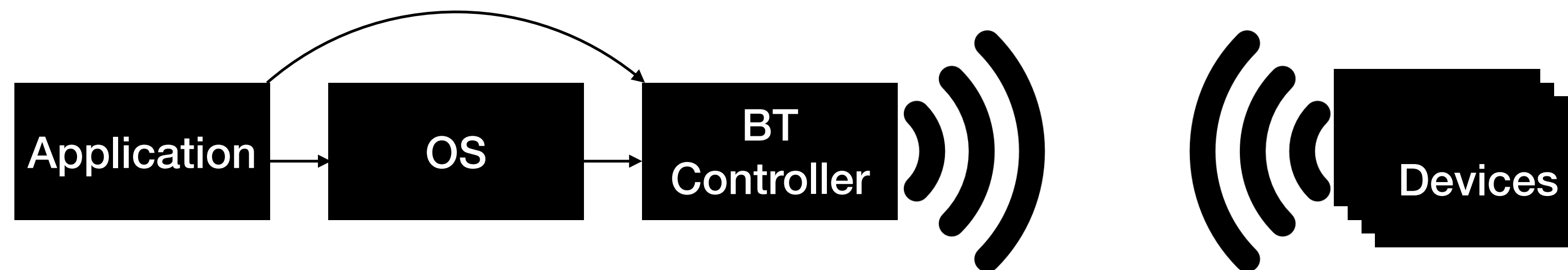

**2thprint by BDADDR OUI**





# Background - *BT Device Address (BDADDR)*

*BT Classic* Addresses



# Background - *BT Device Address (BDADDR)*

## *BT Classic* Addresses





# Background - *BT Device Address (BDADDR)*

## *BT Classic* Addresses

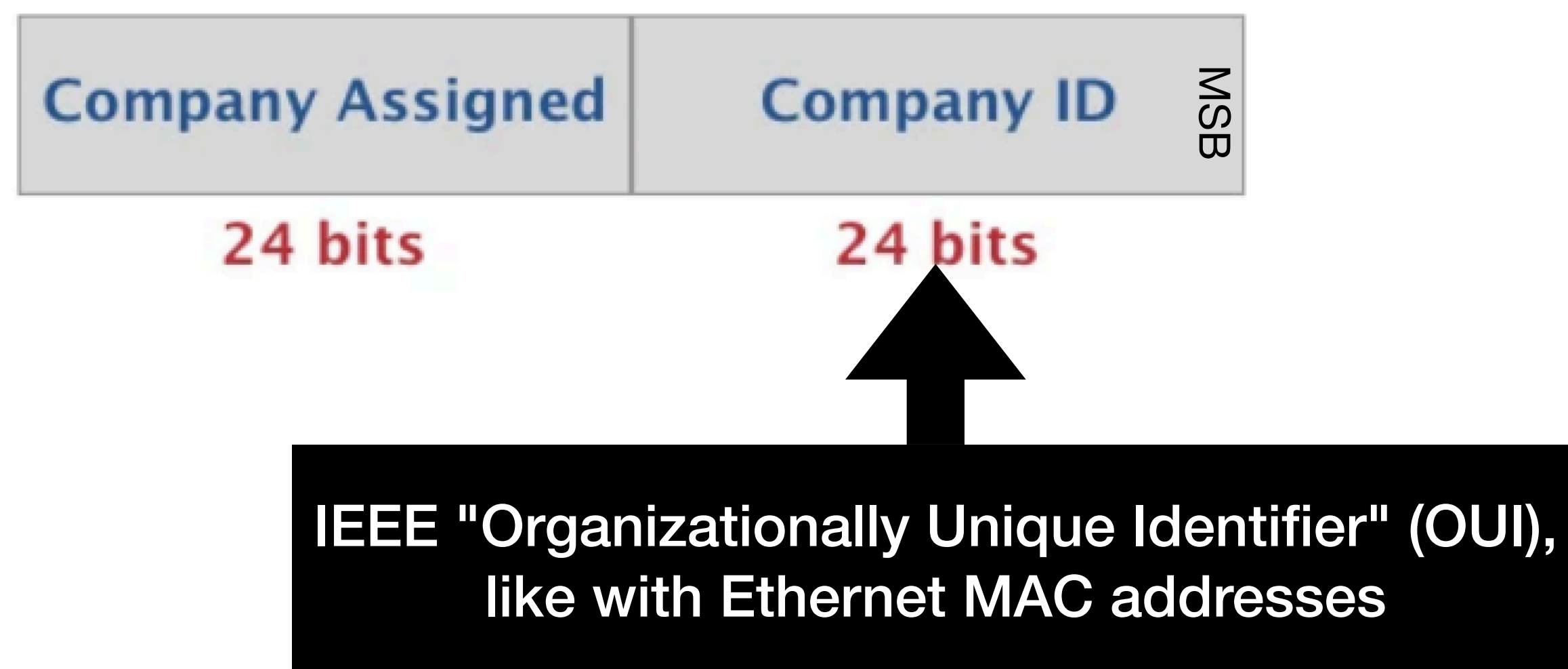



# Background - *BT Device Address (BDADDR)*

*BT Classic* Addresses

00:1f:5f:0d:5a



IEEE "Organizationally Unique Identifier" (OUI),  
like with Ethernet MAC addresses



# Background - *BT Device Address (BDADDR)*

## *BT Classic* Addresses

00:1f:ff:5f:0d:5a

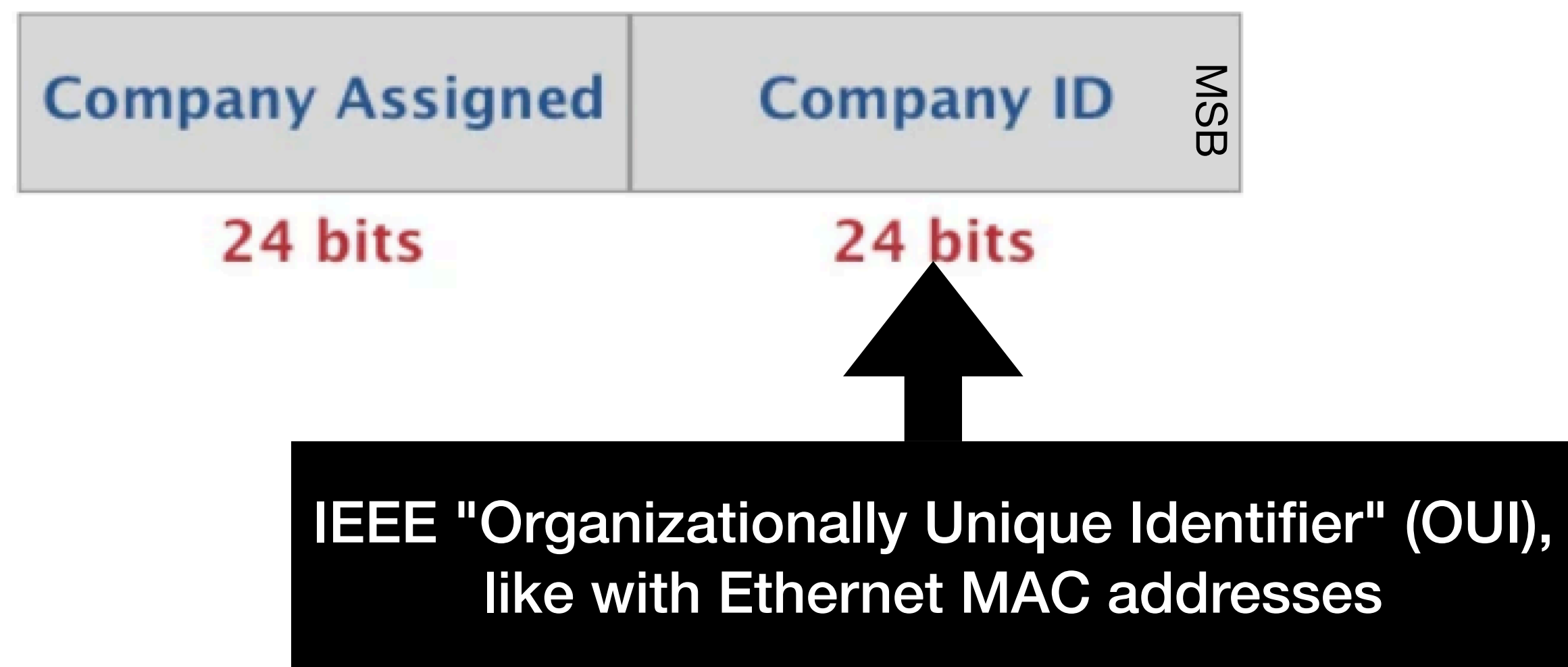



# Background - *BT Device Address (BDADDR)*

## *BT Classic* Addresses



IEEE "Organizationally Unique Identifier" (OUI),  
like with Ethernet MAC addresses

00:1f:ff:5f:0d:5a  
(00:1f:ff): Respironics, Inc.





# Background - *BT Device Address (BDADDR)*

## Bluetooth Address Types (Low Energy)

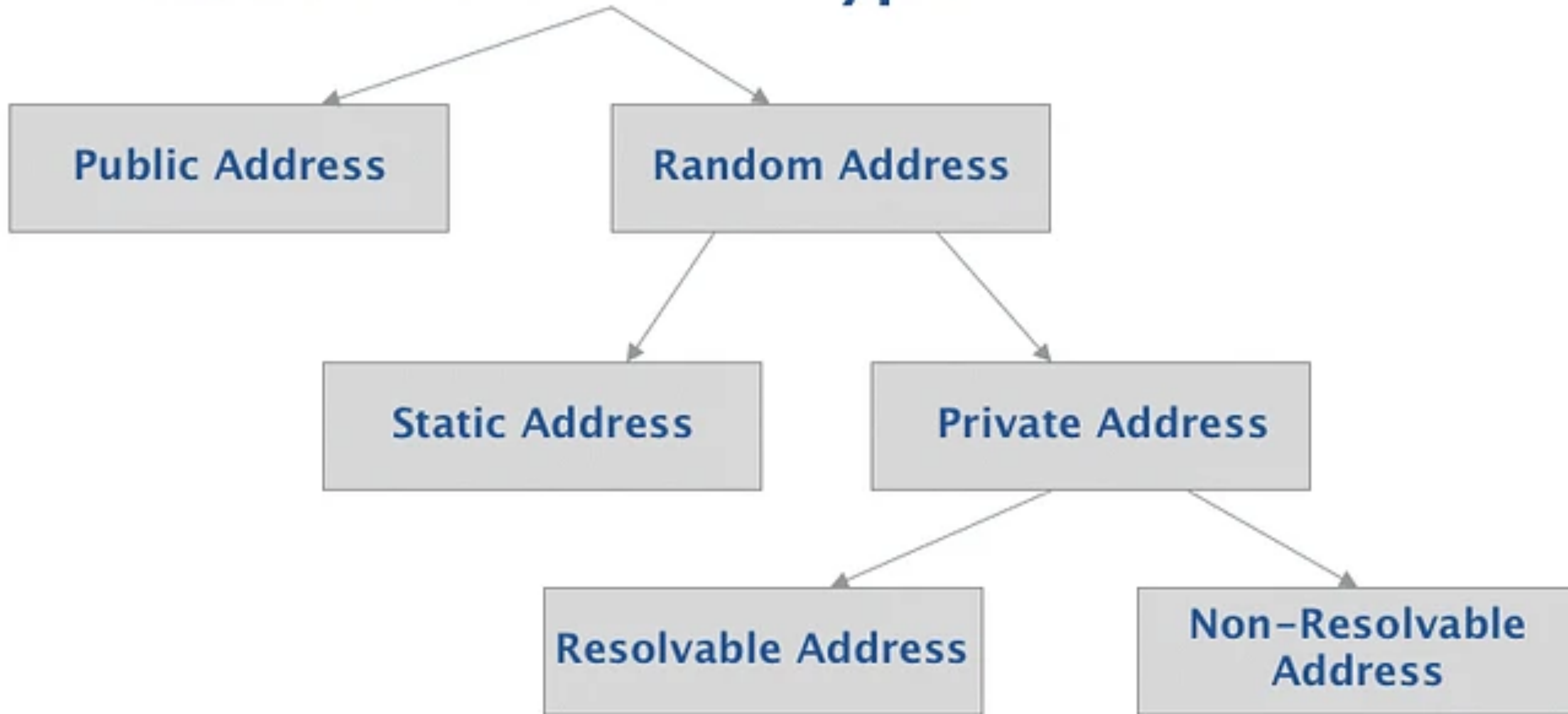



# Background - *BT Device Address (BDADDR)*

## Bluetooth Address Types (Low Energy)

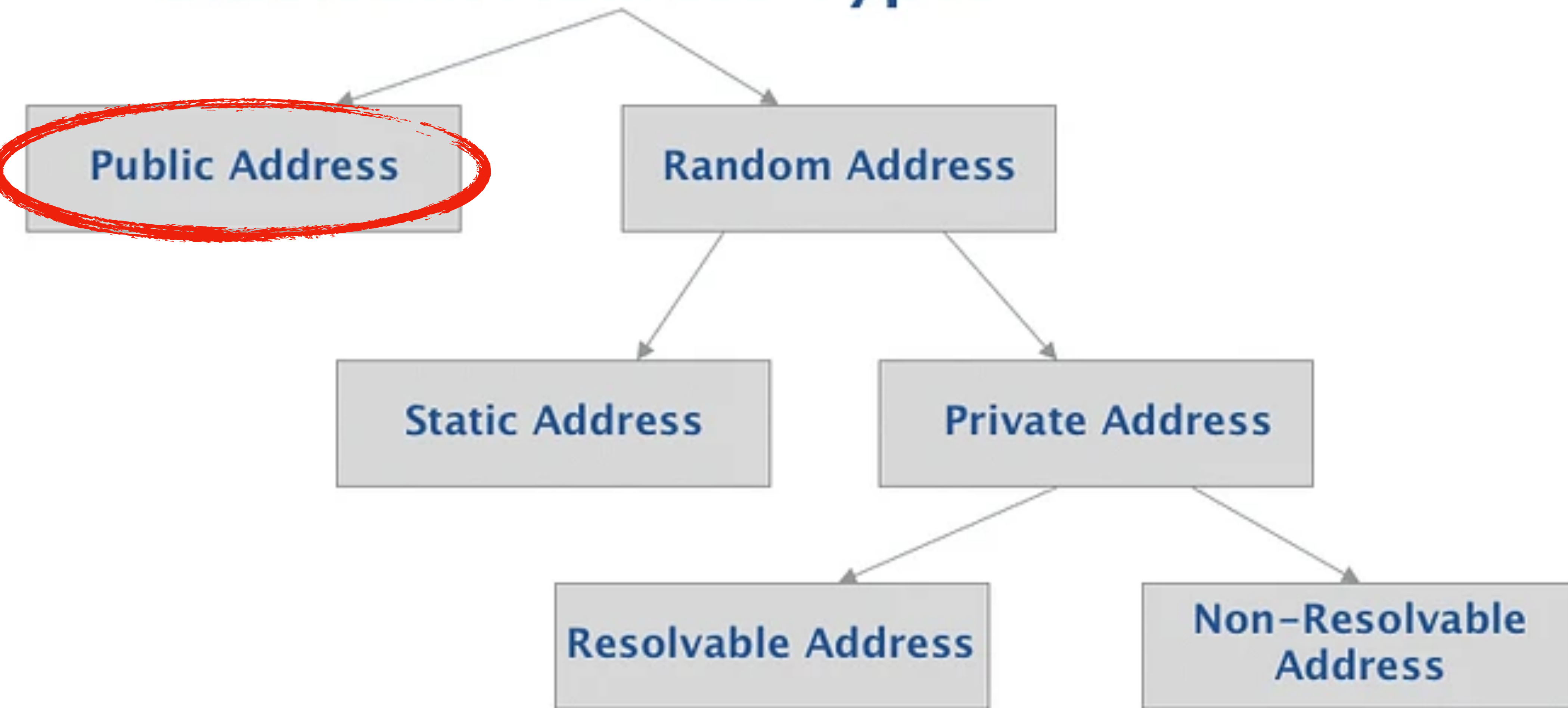



# Background - *BT Device Address (BDADDR)*

## Bluetooth Address Types (Low Energy)

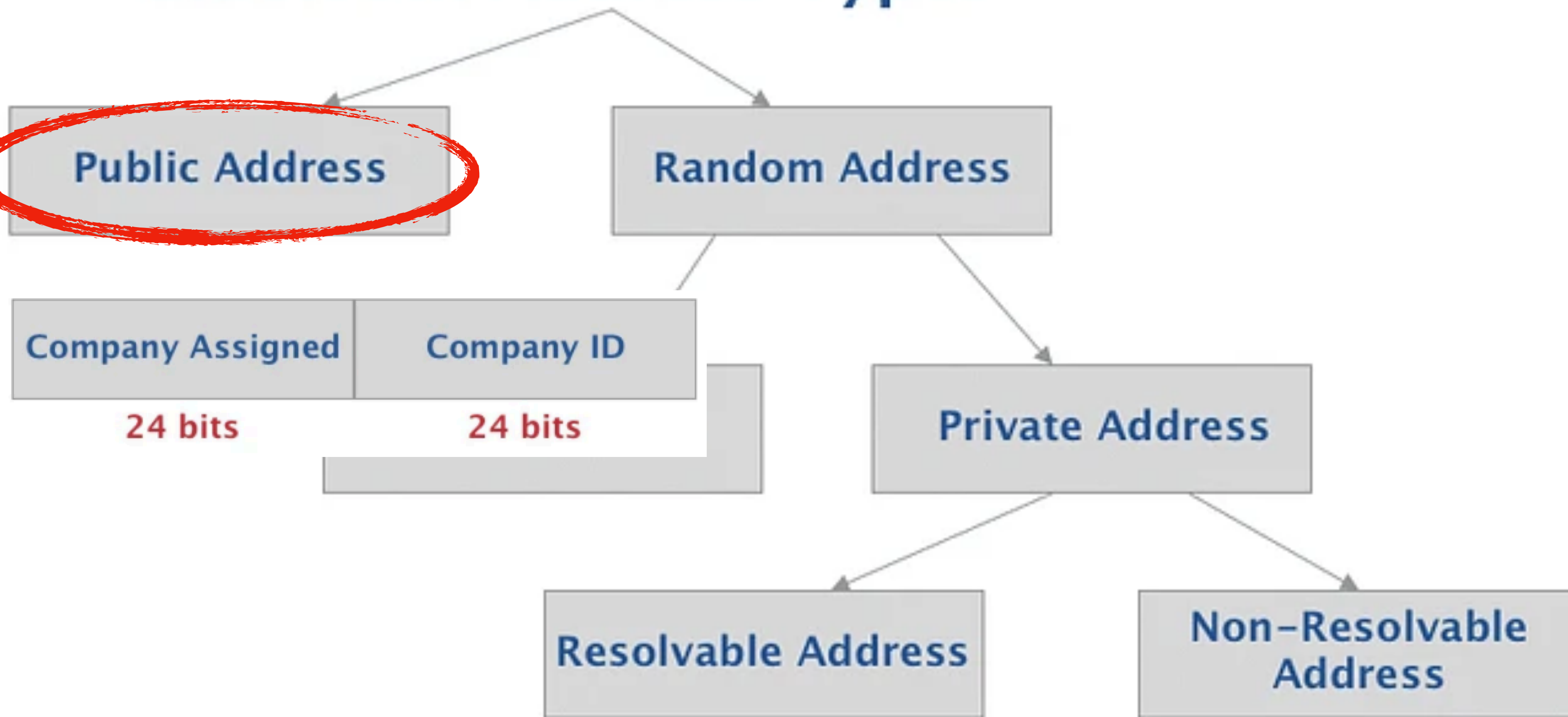



# Background - *BT Device Address (BDADDR)*

## Bluetooth Address Types (Low Energy)

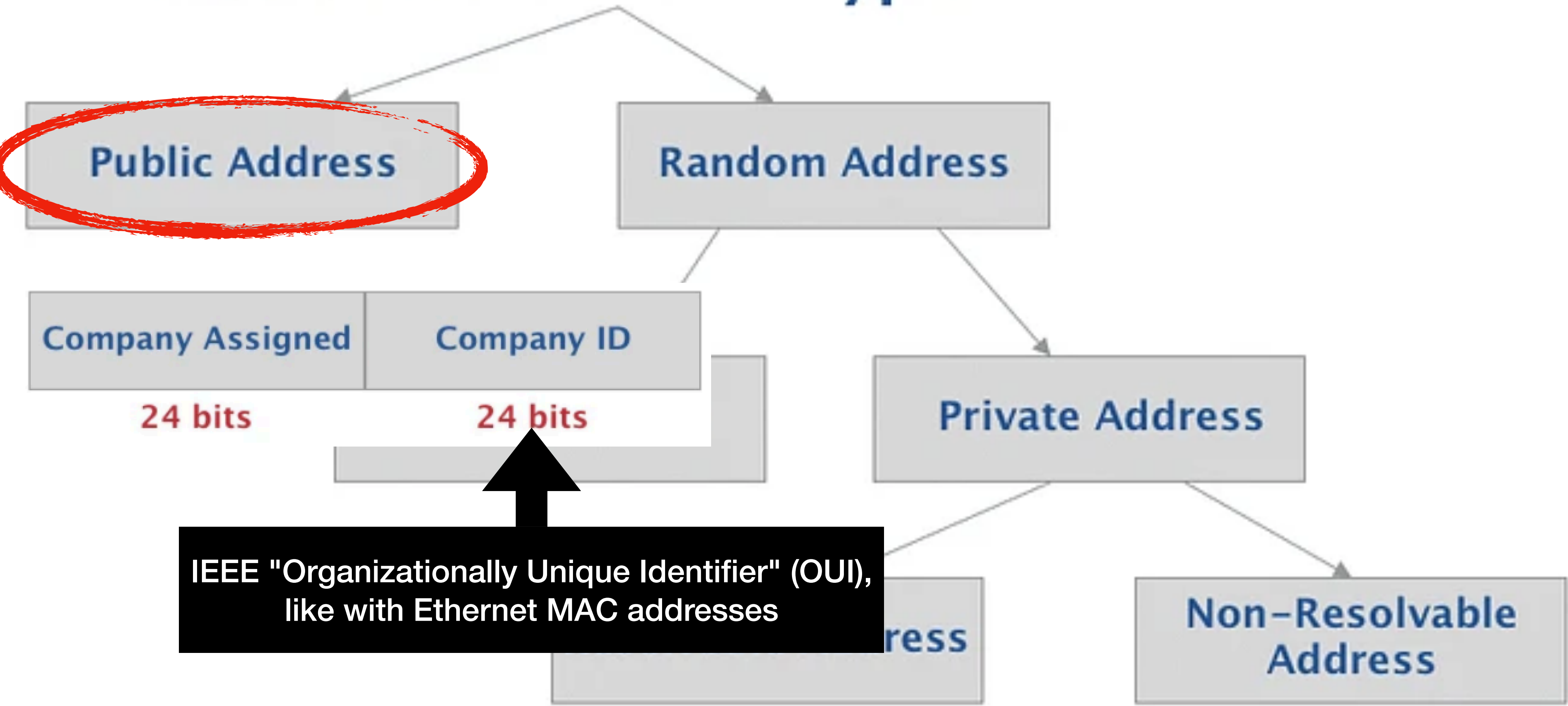



# Overall BDADDR Data

## IEEE OUI Applicability

- **73,047 unique BT Classic BDADDRs** 👍
- **8,392,322 unique BLE BDADDRs**
- **194,151 "public" BDADDRs** 👍
- ~~2,731,623 "random static" BDADDRs~~
- ~~4,950,427 "random resolvable" BDADDRs~~
- ~~299,244 "random non-resolvable" BDADDRs~~
- So OUIPrints applicable to only ~3.2% of the BDADDRs  
(73,047+194,151)/(73,047+8,392,322)

● BLE ● Classic

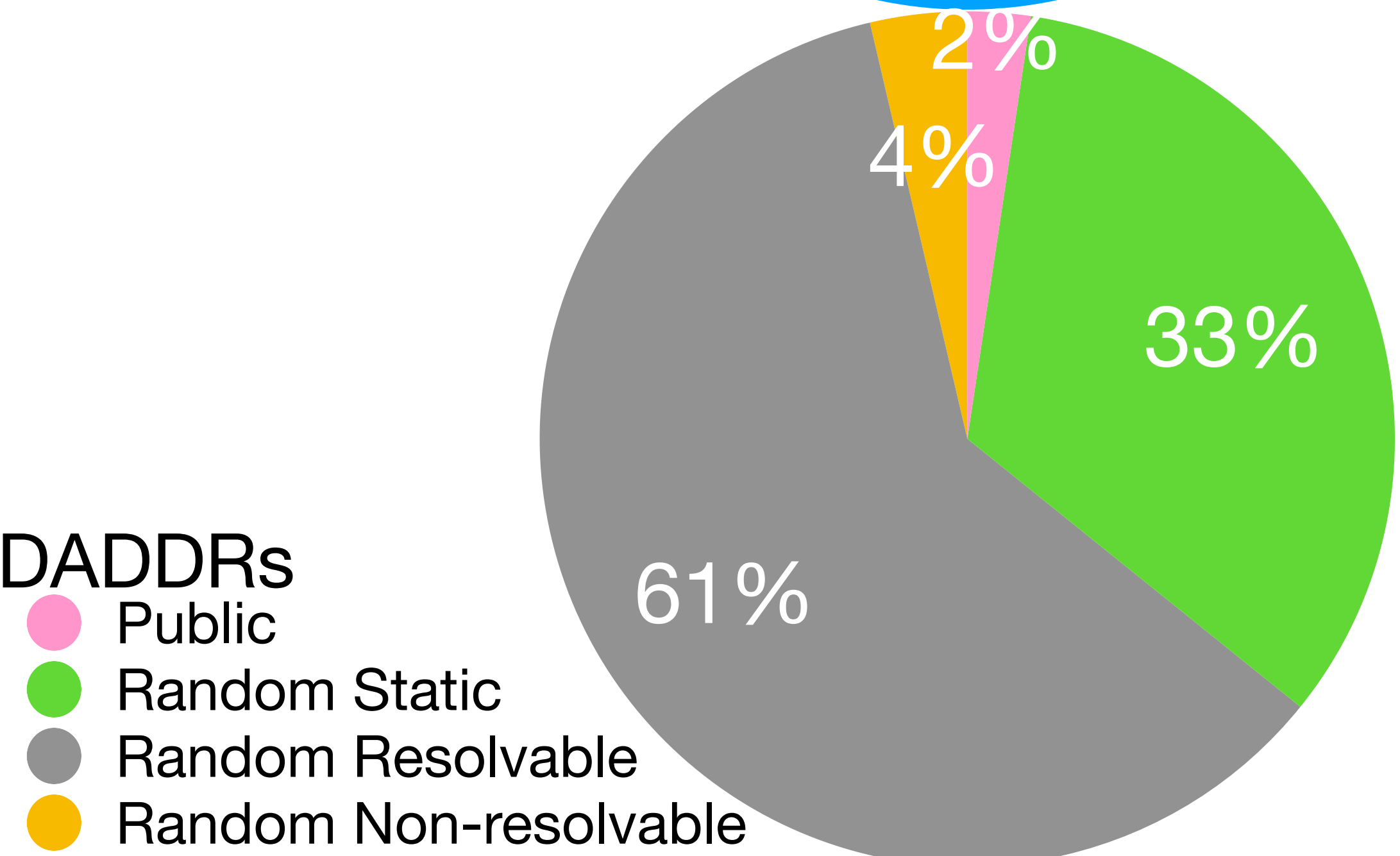
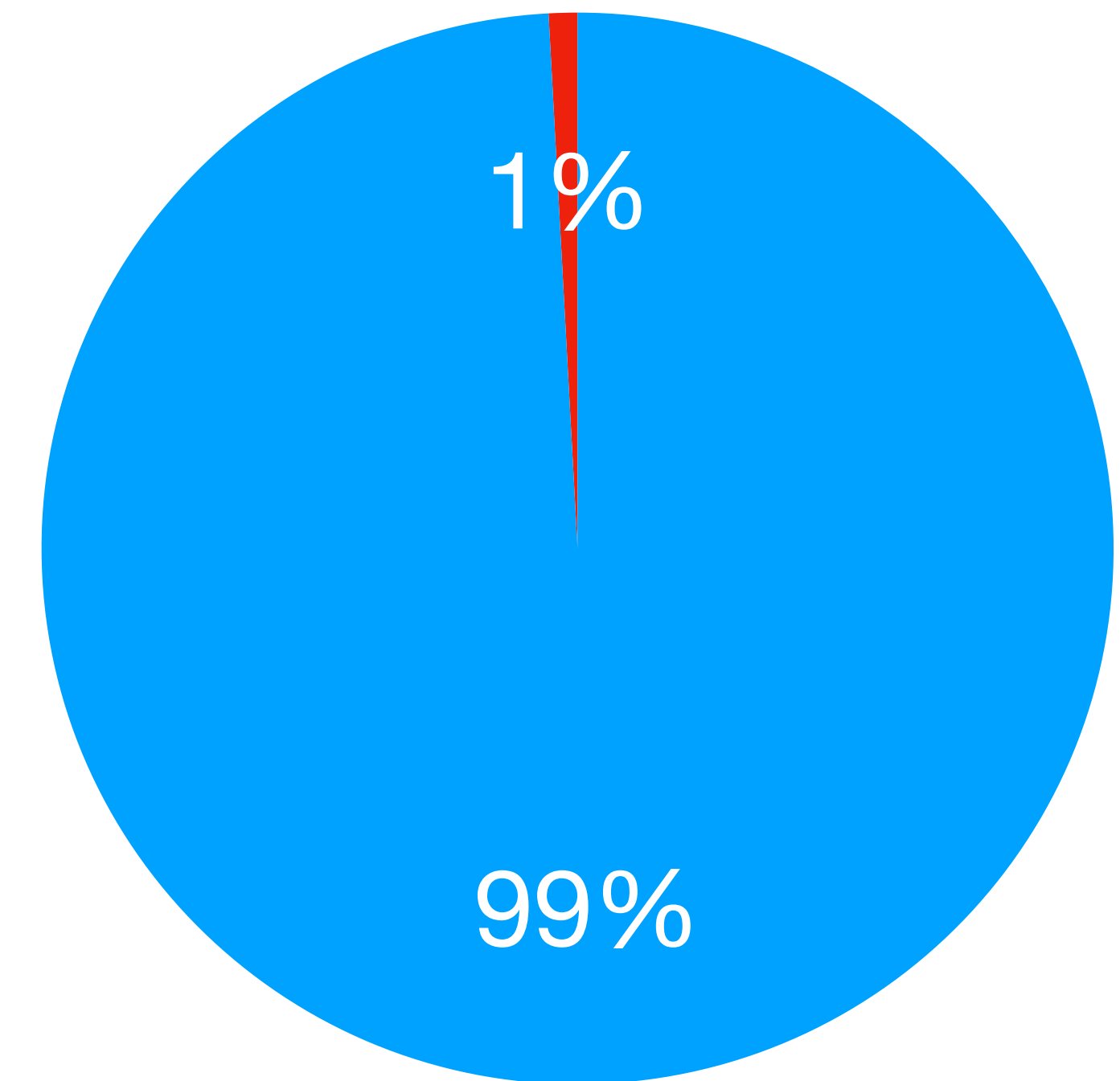



📱 = phone-related, 🚗 = car-related, 🎵 = audio-related, 🍪 = chip-related, 🧩 = module-related



# BTC Data (top 20 of 593 companies seen)

	company_by_bdaddr	found
GPS/Watches/etc	Garmin International	10423
📱 📺	Samsung Electronics Co.,Ltd <i>Qualcomm, Broadcom, MediaTek, Samsung</i> 🍪	6359
📱	OnePlus Technology (Shenzhen) Co., Ltd	3682
🍪	Actions Semiconductor Co.,Ltd.(Cayman Islands)	3036
📱	Apple, Inc. <i>Mostly Broadcom, Sometimes Apple (e.g. AirPods)</i> 🍪	2604
🎵 🚗 🧩	Panasonic Automotive Systems Co.,Ltd	2491
🎵 🚗 🧩	Laird Connectivity	2238
🎵 🚗 🧩	PIONEER CORPORATION	1977
🍪	Intel Corporate	1960
🚗	ALPSALPINE CO,.LTD	1919
📱	GUANGDONG OPPO MOBILE TELECOMMUNICATIONS CORP.,LTD	1648
🧩	AzureWave Technology Inc. <i>NXP, Cypress, MediaTek</i> 🍪	1369
🍪	Texas Instruments	974
📱	Wistron Neweb Corporation	920
🧩	silex technology, Inc. <i>Qualcomm</i> 🍪	890
🎵 🚗 🧩	Shinwa Industries(China) Ltd. <i>Qualcomm/CSR, TI, Cypress, Sunplus</i> 🍪	858
🎵 🚗 🧩	MITSUMI ELECTRIC CO.,LTD. <i>CSR-&gt;Qualcomm</i> 🍪	845
🎵 🚗 🧩	PARROT SA <i>TI</i> 🍪	741
📱 integrator?	Wingtech Mobile Communications Co., Ltd. <i>MediaTek?</i> 🍪	690
🎵 🚗 🍪	Sunplus Technology Co., Ltd.	606



📱 = phone-related, 🚗 = car-related, 🎵 = audio-related, 🍪 = chip-related, 🧩 = module-related



# BTC Data (top 20 of 593 companies seen)

	company_by_bdaddr	found
GPS/Watches/etc	Garmin International	10423
📱 🧩	Samsung Electronics Co.,Ltd <i>Qualcomm, Broadcom, MediaTek, Samsung</i> 🍪	6359
📱	OnePlus Technology (Shenzhen) Co., Ltd	3682
🍪	Actions Semiconductor Co.,Ltd.(Cayman Islands)	3036
📱	Apple, Inc. <i>Mostly Broadcom, Sometimes Apple (e.g. AirPods)</i> 🍪	2604
🎵 🚗 🧩	Panasonic Automotive Systems Co.,Ltd	2491
🎵 🚗 🧩	Laird Connectivity	2238
🎵 🚗 🧩	PIONEER CORPORATION	
🍪	Intel Corporate	
🚗	ALPSALPINE CO,.LTD	1919
📱	GUANGDONG OPPO MOBILE TELECOMMUNICATIONS CORP.,LTD	1648
🧩	AzureWave Technology Inc. <i>NXP, Cypress, MediaTek</i> 🍪	1369
🍪	Texas Instruments	974
📱	Wistron Neweb Corporation	920
🧩	silex technology, Inc. <i>Qualcomm</i> 🍪	890
🎵 🚗 🧩	Shinwa Industries(China) Ltd. <i>Qualcomm/CSR, TI, Cypress, Sunplus</i> 🍪	858
🎵 🚗 🧩	MITSUMI ELECTRIC CO.,LTD. <i>CSR-&gt;Qualcomm</i> 🍪	845
🎵 🚗 🧩	PARROT SA <i>TI</i> 🍪	741
📱 integrator?	Wingtech Mobile Communications Co., Ltd. <i>MediaTek?</i> 🍪	690
🎵 🚗 🍪	Sunplus Technology Co., Ltd.	606



**Note! My data is skewed towards vehicles, because I like to put my sniffers over freeways!**



📱 = phone-related, 🚗 = car-related, 🎵 = audio-related, 🍪 = chip-related, 🧩 = module-related



# BLE Data (top 20 of 608 companies seen)

	company_by_bdaddr	found	
	Texas Instruments	31799	
	VXi Corporation	25190	
	Samsung Electronics Co.,Ltd Qualcomm, Broadcom, MediaTek, Samsung	12340	
	Bose Corporation	8475	
	Logitech, Inc	4980	
	Cambridge Mobile Telematics, Inc. CSR->Qualcomm	4958	
	Apple, Inc. Mostly Broadcom, Sometimes Apple (e.g. AirPods)	4821	
	Silicon Laboratories	3802	
	Espressif Inc.	2975	
BLE beacons	Shenzhen Minew Technologies Co., Ltd.	2462	
	Murata Manufacturing Co., Ltd. Nordic, Cypress, CSR, Onsemi, Dialog	2276	
	Telink Semiconductor (Taipei) Co. Ltd.	1943	
	Shenzhen Jingxun Software Telecommunication Technology Co.,Ltd	1879	RealTek, Airoha
GPS/Watches/etc	Garmin International	1651	
	Sunitec Enterprise Co.,Ltd	1426	Broadcom
BLE beacons	Aruba, a Hewlett Packard Enterprise Company	1388	
LED lights & sensors	Shenzhen Intellirocks Tech co.,ltd	1139	Telink
Teslas	Shanghai Rui Rui Communication Technology Co.Ltd.	1070	(TI bought OUI?)
	ALPSALPINE CO,.LTD	969	
🎵 Hearing aids	Starkey Labs Inc.	934	





## Of what I want to know

- If the BDADDR maps to a chip-maker, we have an idea of what chip maker is being used with high probability

"Texas Instruments"	"Silicon Laboratories"	"Intel Corporate"
"Telink Semiconductor (Taipei) Co. Ltd."	"Cambridge Silicon Radio"	"Espressif Inc."
"Nordic Semiconductor ASA"	"NXP Semiconductors"	"NXP France Semiconductors France"
"NXP Semiconductor (Tianjin) LTD."	"NXP (China) Management Ltd."	"Microchip Technology Inc."
"Broadcom"	"Qualcomm Technologies International, Ltd. (QTIL)"	"REALTEK SEMICONDUCTOR CORP."

- For some other names (like module-makers), we might know that there's only 1 or 2 chips they ever use, though of course that can change
- Need to collect that data over time



# The First Traces

## Of what I want to know

- If the BDADDR maps to a chip-maker, we have an idea of what chip maker is being used with high probability

"Texas Instruments"	"Silicon Laboratories"	"Intel Corporate"
"Telink Semiconductor (Taipei) Co. Ltd."	"Cambridge Silicon Radio"	"Espressif Inc."
"Nordic Semiconductor ASA"	"NXP Semiconductors"	"NXP France Semiconductors France"
"NXP Semiconductor (Tianjin) LTD."	"NXP (China) Management Ltd."	"Microchip Technology Inc."
"Broadcom"	"Qualcomm Technologies International, Ltd. (QTIL)"	"REALTEK SEMICONDUCTOR CORP."

- For some other names (like module-makers), we might know that there's only 1 or 2 chips they ever use, though of course that can change
- Need to collect that data over time



# What I Want

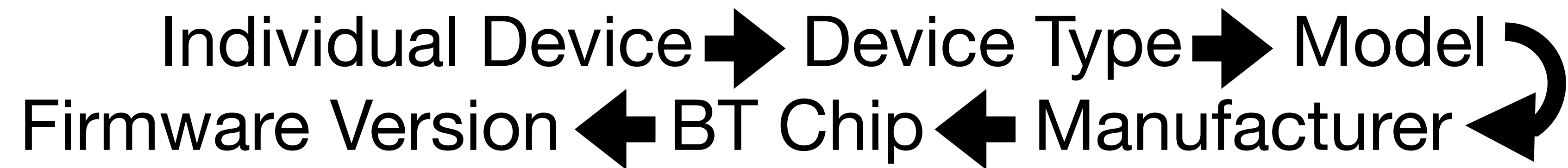



# What I Want

BDADDR = **FC:A8:9B:11:22:33**

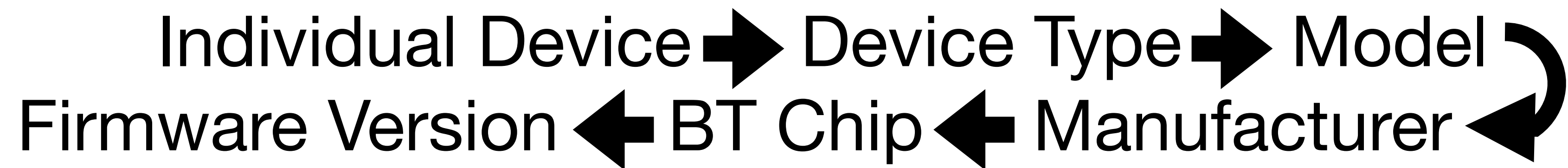



# What I Want

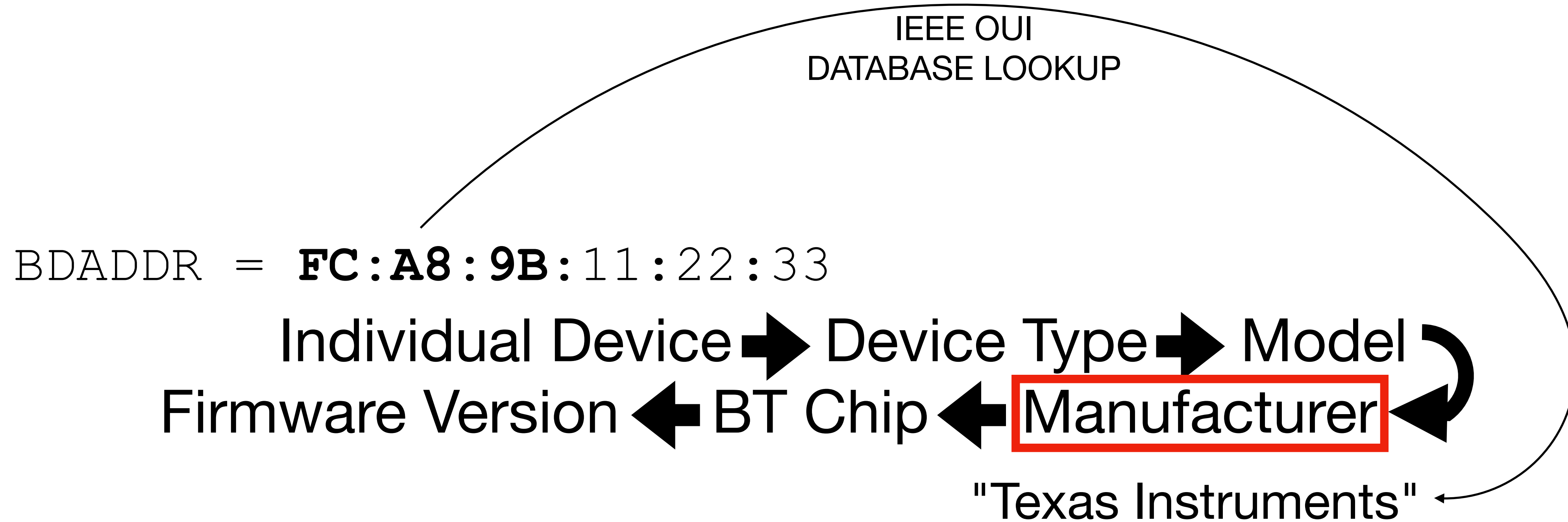



# What I Want

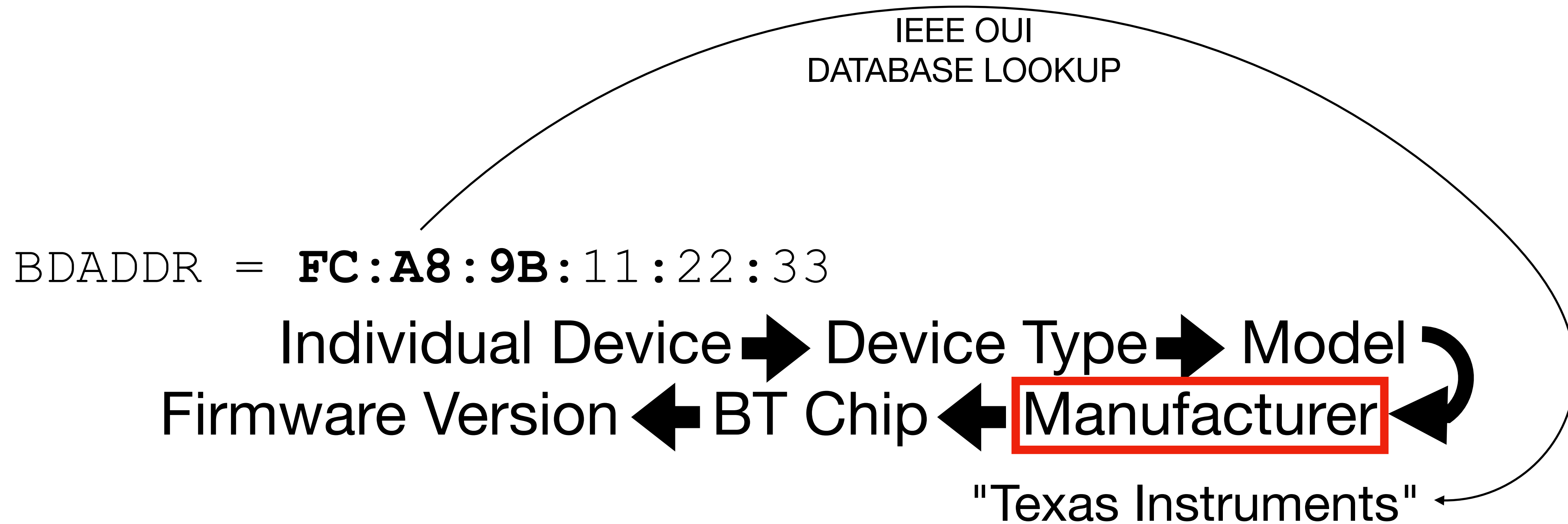

## ASSUMPTION:

OUIPrint == ChipPrint, for OUI == {Silicon Vendor OUIs}



# What I Want

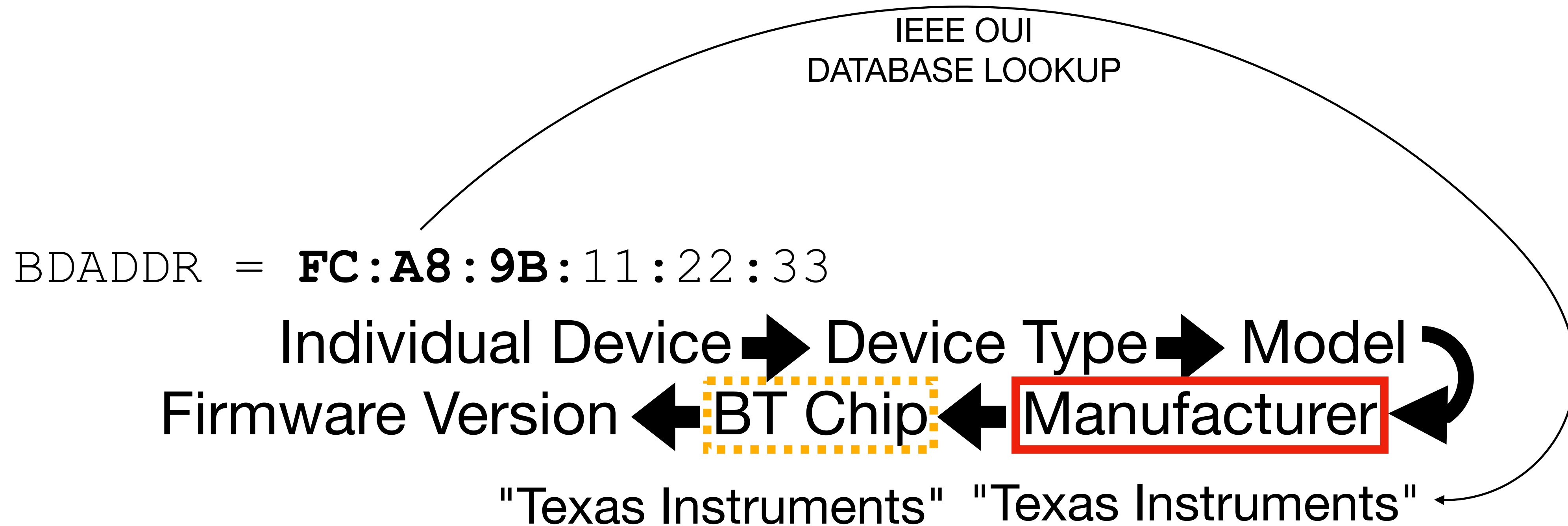

## ASSUMPTION:

OUIPrint == ChipPrint, for OUI == {Silicon Vendor OUIs}



# OUIPrints Beget Names

- If we have the company name from a BDADDR, it may help us track down model names from a company, and consequently create more 2thprints-by-name.

- Example:

00:1e:42:33:59:e5	Teltonika	MCX201_1689933	<a href="https://www.moreycorp.com/products/mcx201/">https://www.moreycorp.com/products/mcx201/</a>
00:1e:42:35:51:64	Teltonika	MCX201_1689933	
00:1e:42:50:9f:ea	Teltonika	FMM00A_8585657	
00:1e:42:58:15:df	Teltonika	862464066707824	-\_(\ツ)\_/-
00:1e:42:a7:bd:49	Teltonika	FMB122_6048388	





# OUIPrints Beget Names

- If we have the company name from a BDADDR, it may be possible to find model names from a company, and consequently create a name.
- Example:



00:1e:42:33:59:e5	Teltonika	MCX201_1689933	<a href="https://www.moreycorp.com/products/mcx201/">https://www.moreycorp.com/products/mcx201/</a>
00:1e:42:35:51:64	Teltonika	MCX201_1689933	
00:1e:42:50:9f:ea	Teltonika	FMM00A_8585657	
00:1e:42:58:15:df	Teltonika	862464066707824	-\_(\ツ)\_/-
00:1e:42:a7:bd:49	Teltonika	FMB122_6048388	



# OUIPrints Beget Names

- If we have the company name from a BDADDR, it may be possible to create model names from a company, and consequently create a name.
- Example:



00:1e:42:33:59:e5	Teltonika	MCX201_1689933	<a href="https://www.moreycorp.com/products/mcx201/">https://www.moreycorp.com/products/mcx201/</a>
00:1e:42:35:51:64	Teltonika	MCX201_1689933	
00:1e:42:50:9f:ea	Teltonika	FMM00A_8585657	
00:1e:42:58:15:df	Teltonika	862464066707824	-\_(\ツ)\_/-
00:1e:42:a7:bd:49	Teltonika	FMB122_6048388	



# OUIPrints Beget Names

- If we have the company name from a BDADDR, it may help us track down model names from a company, and consequently create more 2thprints-by-name.
- Example:

00:1e:42:33:59:e5	Teltonika	MCX201_1689933	<a href="https://www.moreycorp.com/products/mcx201/">https://www.moreycorp.com/products/mcx201/</a>
00:1e:42:35:51:64	Teltonika	MCX201_1689933	
00:1e:42:50:9f:ea	Teltonika	FMM00A_8585657	
00:1e:42:58:15:df	Teltonika	862464066707824	-\_(\ツ)\_/-
00:1e:42:a7:bd:49	Teltonika	FMB122_6048388	



# OUIPrints Beget Names

- If we have the company name from a BDADDR, it may help us track down model names from a company, and consequently create more 2thprints-by-name.
- Example:

00:1e:42:33:59:e5	Teltonika	MCX201_1689933	<a href="https://www.moreycorp.com/products/mcx201/">https://www.moreycorp.com/products/mcx201/</a>
00:1e:42:35:51:64	Teltonika	MCX201_1689933	
00:1e:42:50:9f:ea	Teltonika	FMM00A_8585657	<a href="https://wiki.teltonika-gps.com/view/FMM00A_Bluetooth_settings">https://wiki.teltonika-gps.com/view/FMM00A_Bluetooth_settings</a>
00:1e:42:58:15:df	Teltonika	862464066707824	-\_(\ツ)\_/-
00:1e:42:a7:bd:49	Teltonika	FMB122_6048388	<a href="https://wiki.teltonika-gps.com/view/FMB122_Bluetooth_settings">https://wiki.teltonika-gps.com/view/FMB122_Bluetooth_settings</a>



# OUIPrints Beget Names

[https://wiki.teltonika-gps.com/view/FMM00A\\_Bluetooth\\_settings](https://wiki.teltonika-gps.com/view/FMM00A_Bluetooth_settings)

[EOL PRODUCTS](#)[FAST & EASY TRACKERS](#)[FREQUENTLY ASKED QUESTIONS - FAQ](#)[OBD TRACKERS](#)

# Beget Names

- > FMB001
- > FMB002
- > FMB003
- > FMC001
- > FMC003
- > FMC00A
- > FMM001
- > FMM003
- > FMM00A

[https://wiki.teltonika-gps.com/view/FMM00A\\_Bluetooth\\_settings](https://wiki.teltonika-gps.com/view/FMM00A_Bluetooth_settings)

[EOL PRODUCTS](#)[FAST & EASY TRACKERS](#)[FREQUENTLY ASKED QUESTIONS - FAQ](#)[OBD TRACKERS](#)

# Beget Names

- > FMB001
- > FMB002
- > FMB003
- > FMC001
- > FMC003
- > FMC00A
- > FMM001
- > FMM003
- > FMM00A

[https://wiki.teltonika-gps.com/view/FMM00A\\_Bluetooth\\_settings](https://wiki.teltonika-gps.com/view/FMM00A_Bluetooth_settings)

# search for networks

WiFi
  Cell
  BT

Lat:  to:

Lon:  to:

Last Updated:

BSSID/MAC:

Network Name (wildcards<sup>1</sup>: % and \_):

Only Nets I Was the First to See

<sup>1</sup> %: 0-or-more characters, '\_': a single character.

- > FMM00A
- > FMM001
- > FMM003
- > FMM00A

✖ FMM00A_8488746 QoS: 0 type: BT	00:1e:42:50:26:98 ?	2023-04-13 - 2023-04-13
✖ FMM00A_8585657 QoS: 0 type: BT	00:1e:42:51:77:e9 ?	2023-06-01 - 2023-06-01
✖ FMM00A_8682488 QoS: 0 type: BT	00:1e:42:52:72:6c ?	2023-04-22 - 2023-04-24
✖ FMM00A_3268558 QoS: 0 type: BT	00:1e:42:55:0b:22 ?	2023-04-25 - 2023-04-25
✖ FMM00A_8585657 QoS: 0 type: BT	00:1e:42:56:92:a9 ?	2023-05-27 - 2023-05-30
✖ FMM00A_8585657 QoS: 0 type: BT	00:1e:42:58:23:6f ?	2023-04-19 - 2023-04-19
✖ FMM00A_8682488 QoS: 0 type: BT	00:1e:42:58:a8:0f ?	2023-05-09 - 2023-05-09
✖ FMM00A_8682488 QoS: 0 type: BT	00:1e:42:59:88:4e ?	2023-05-23 - 2023-05-23
✖ FMM00A_8585657 QoS: 0 type: BT	00:1e:42:5a:1c:07 ?	2023-06-06 - 2023-06-06
✖ FMM00A_8585657 QoS: 0 type: BT	00:1e:42:5b:07:a8 ?	2023-04-30 - 2023-04-30





[EOL PRODUCTS](#)[FAST & EASY TRACKERS](#)[FREQUENTLY ASKED QUESTIONS - FAQ](#)[OBD TRACKERS](#)

# Beget Names

- > FMB001
- > FMB002
- > FMB003
- > FMC001
- > FMC003
- > FMC00A
- > FMM001
- > FMM003
- > FMM00A

[https://wiki.teltonika-gps.com/view/FMM00A\\_Bluetooth\\_settings](https://wiki.teltonika-gps.com/view/FMM00A_Bluetooth_settings)

EOL PRODUCTS

FAST & EASY TRACKERS

FREQUENTLY ASKED QUESTIONS - FAQ

# Beget Names

OBD TRACKERS

- > FMB001
- > FMB002
- > FMB003
- > FMC001
- > FMC003
- > FMC00A
- > FMM001
- > FMM003
- > FMM00A

[https://wiki.teltonika-gps.com/view/FMM00A\\_Bluetooth\\_settings](https://wiki.teltonika-gps.com/view/FMM00A_Bluetooth_settings)

EOL PRODUCTS

FAST & EASY TRACKERS

FREQUENTLY ASKED QUESTIONS - FAQ

# Beget Names

OBD TRACKERS

- > FMB001
- > FMB002
- > FMB003
- > FMC001
- > FMC003
- > FMC00A
- > FMM001
- > **FMM003**
- > FMM00A

[https://wiki.teltonika-gps.com/view/FMM00A\\_Bluetooth\\_settings](https://wiki.teltonika-gps.com/view/FMM00A_Bluetooth_settings)

# search for networks

WiFi
  Cell
  BT

Lat:  to:

Lon:  to:









Last Updated:

BSSID/MAC:

Network Name (wildcards<sup>1</sup>: % and \_):

Only Nets I Was the First to See

- > FMC001
- > FMC003
- > FMC00A
- > FMM001
- > FMM003
- > FMM00A









	FMM003_2524025	QoS: 2	type: BT	00:1e:42:2c:b1:10	?	2022-09-25 - 2022-12-03
	FMM003_2524025	QoS: 0	type: BT	00:1e:42:2d:8f:f0	?	2022-12-03 - 2022-12-02
	FMM003_2524025	QoS: 0	type: BT	00:1e:42:32:92:03	?	2022-10-30 - 2022-10-29
	FMM003_2524025	QoS: 0	type: BT	00:1e:42:32:c6:73	?	2022-10-08 - 2022-10-08
	FMM003_6805451	QoS: 0	type: BT	00:1e:42:5b:c0:4d	?	2023-05-01 - 2023-05-01
	FMM003_DTM449	QoS: 0	type: BT	00:1e:42:5c:dc:68	?	2023-05-23 - 2023-05-23
	FMM003_6805451	QoS: 0	type: BT	00:1e:42:5e:db:6b	?	2023-02-20 - 2023-02-20
	FMM003_6735591	QoS: 0	type: BT	4d:05:95:2b:62:61	?	2019-01-15 - 2023-05-05



# search for networks

WiFi
  Cell
  BT

Lat:  to:   
 Lon:  to:   
 Last Updated:   
 BSSID/MAC:   
 Network Name (wildcards<sup>1</sup>: % and \_):  
  
 Only Nets I Was the First to See

	FMM003_2524025	QoS: 2	type: BT	00:1e:42:2c:b1:10	?	2022-09-25 - 2022-12-03
	FMM003_2524025	QoS: 0	type: BT	00:1e:42:2d:8f:f0	?	2022-12-03 - 2022-12-02
	FMM003_2524025	QoS: 0	type: BT	00:1e:42:32:92:03	?	2022-10-30 - 2022-10-29
	FMM003_2524025	QoS: 0	type: BT	00:1e:42:32:c6:73	?	2022-10-08 - 2022-10-08
	FMM003_6805451	QoS: 0	type: BT	00:1e:42:5b:c0:4d	?	2023-05-01 - 2023-05-01
	FMM003_DTM449	QoS: 0	type: BT	00:1e:42:5c:dc:68	?	2023-05-23 - 2023-05-23
	FMM003_6805451	QoS: 0	type: BT	00:1e:42:5e:db:6b	?	2023-02-20 - 2023-02-20
	FMM003_6735591	QoS: 0	type: BT	4d:05:95:2b:62:61	?	2019-01-15 - 2023-05-05



- > FMC001
- > FMC003

```

Morey (Teltonika by BDADDR) MCX201 telematics LTE/GNSS/BLE tracker (https://www.moreycorp.com/products/mcx201/, http://3.126.97.106/view/MCX201_First_Start, saw two different BDADDRs with the same last 7...)", "^MCX201_[0-9]{7}$"
"Teltonika FMM00A telematics tracker (https://wiki.teltonika-gps.com/view/FMM00A_Bluetooth_settings)", "^FMM00A_[0-9]{7}$"
"Teltonika FMB122 telematics tracker (https://wiki.teltonika-gps.com/view/FMB122_Bluetooth_settings)", "^FMB122_[0-9]{7}$"
"Teltonika FMB110 telematics tracker (Based on naming convention, and model list here: https://wiki.teltonika-gps.com/view/FMB122_Bluetooth_settings, plus sightings in WiGLE data)", "^FMB110_[0-9]{7}$"
"Teltonika FMB120 telematics tracker (Based on naming convention, and model list here: https://wiki.teltonika-gps.com/view/FMB122_Bluetooth_settings, plus sightings in WiGLE data)", "^FMB120_[0-9]{7}$"
"Teltonika FMB125 telematics tracker (Based on naming convention, and model list here: https://wiki.teltonika-gps.com/view/FMB122_Bluetooth_settings, plus sightings in WiGLE data)", "^FMB125_[0-9]{7}$"
"Teltonika FMB130 telematics tracker (Based on naming convention, and model list here: https://wiki.teltonika-gps.com/view/FMB122_Bluetooth_settings, plus sightings in WiGLE data)", "^FMB130_[0-9]{7}$"
"Teltonika FMB202 telematics tracker (Based on naming convention, and model list here: https://wiki.teltonika-gps.com/view/FMB122_Bluetooth_settings, plus sightings in WiGLE data)", "^FMB202_[0-9]{7}$"
"Teltonika FMB204 telematics tracker (Based on naming convention, and model list here: https://wiki.teltonika-gps.com/view/FMB122_Bluetooth_settings, plus sightings in WiGLE data)", "^FMB204_[0-9]{7}$"
"Teltonika FMB208 telematics tracker (Based on naming convention, and model list here: https://wiki.teltonika-gps.com/view/FMB122_Bluetooth_settings, plus sightings in WiGLE data)", "^FMB208_[0-9]{7}$"
"Teltonika FMB209 telematics tracker (Based on naming convention, and model list here: https://wiki.teltonika-gps.com/view/FMB122_Bluetooth_settings, plus sightings in WiGLE data)", "^FMB209_[0-9]{7}$"
"Teltonika FMB225 telematics tracker (Based on naming convention, and model list here: https://wiki.teltonika-gps.com/view/FMB122_Bluetooth_settings, plus sightings in WiGLE data)", "^FMB225_[0-9]{7}$"
"Teltonika FMB230 telematics tracker (Based on naming convention, and model list here: https://wiki.teltonika-gps.com/view/FMB122_Bluetooth_settings, plus sightings in WiGLE data)", "^FMB230_[0-9]{7}$"
"Teltonika FMC125 telematics tracker (Based on naming convention, and model list here: https://wiki.teltonika-gps.com/view/FMB122_Bluetooth_settings, plus sightings in WiGLE data)", "^FMC125_[0-9]{7}$"
"Teltonika FMC130 telematics tracker (Based on naming convention, and model list here: https://wiki.teltonika-gps.com/view/FMB122_Bluetooth_settings, plus sightings in WiGLE data)", "^FMC130_[0-9]{7}$"
"Teltonika FMC13A telematics tracker (Based on naming convention, and model list here: https://wiki.teltonika-gps.com/view/FMB122_Bluetooth_settings, plus sightings in WiGLE data)", "^FMC13A_[0-9]{7}$"
"Teltonika FMC225 telematics tracker (Based on naming convention, and model list here: https://wiki.teltonika-gps.com/view/FMB122_Bluetooth_settings, plus sightings in WiGLE data)", "^FMC225_[0-9]{7}$"
"Teltonika FMC230 telematics tracker (Based on naming convention, and model list here: https://wiki.teltonika-gps.com/view/FMB122_Bluetooth_settings, plus sightings in WiGLE data)", "^FMC230_[0-9]{7}$"
"Teltonika FMM125 telematics tracker (Based on naming convention, and model list here: https://wiki.teltonika-gps.com/view/FMB122_Bluetooth_settings, plus sightings in WiGLE data)", "^FMM125_[0-9]{7}$"
"Teltonika FMM130 telematics tracker (Based on naming convention, and model list here: https://wiki.teltonika-gps.com/view/FMB122_Bluetooth_settings, plus sightings in WiGLE data)", "^FMM130_[0-9]{7}$"
"Teltonika FMM13A telematics tracker (Based on naming convention, and model list here: https://wiki.teltonika-gps.com/view/FMB122_Bluetooth_settings, plus sightings in WiGLE data)", "^FMM13A_[0-9]{7}$"
"Teltonika FMM230 telematics tracker (Based on naming convention, and model list here: https://wiki.teltonika-gps.com/view/FMB122_Bluetooth_settings, plus sightings in WiGLE data)", "^FMM230_[0-9]{7}$"
"Teltonika FMB001 telematics tracker (Based on naming convention, and model list here: https://wiki.teltonika-gps.com/view/FMM00A_Bluetooth_settings, plus sightings in WiGLE data)", "^FMB001_[0-9]{7}$"
"Teltonika FMB002 telematics tracker (Based on naming convention, and model list here: https://wiki.teltonika-gps.com/view/FMM00A_Bluetooth_settings, plus sightings in WiGLE data)", "^FMB002_[0-9]{7}$"
"Teltonika FMB003 telematics tracker (Based on naming convention, and model list here: https://wiki.teltonika-gps.com/view/FMM00A_Bluetooth_settings, plus sightings in WiGLE data)", "^FMB003_[0-9]{7}$"
"Teltonika FMM001 telematics tracker (Based on naming convention, and model list here: https://wiki.teltonika-gps.com/view/FMM00A_Bluetooth_settings, plus sightings in WiGLE data)", "^FMM001_[0-9]{7}$"
"Teltonika FMM003 telematics tracker (Based on naming convention, and model list here: https://wiki.teltonika-gps.com/view/FMM00A_Bluetooth_settings, plus sightings in WiGLE data)", "^FMM003_[0-9]{7}$"
"Teltonika FMM00A telematics tracker (Based on naming convention, and model list here: https://wiki.teltonika-gps.com/view/FMM00A_Bluetooth_settings, plus sightings in WiGLE data)", "^FMM00A_[0-9]{7}$"
    
```

**2thprint by Link Layer Version Info**



**or**





# 2thprint by Link Layer Version Information

## LL\_VERSION\_IND (BLE), LMP\_version\_res (BTC)

- BTC has Link Management Protocol (LMP) and BLE has Link-Layer (LL) Control packets, that can be sent to request some chip and firmware version information
- These can be sent/received *without* any sort of BT pairing/bonding!

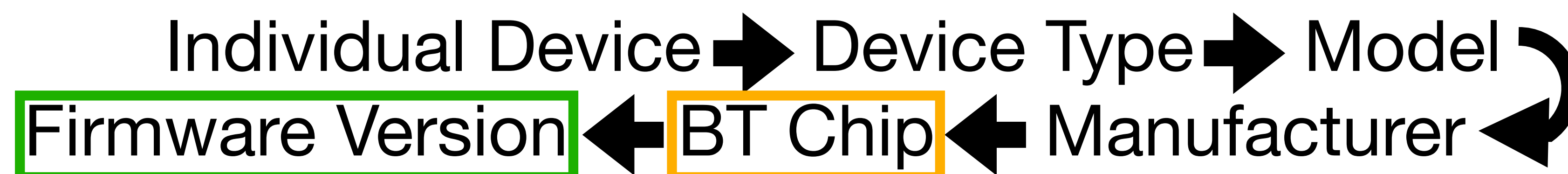

# 2thprint by

## LMP\_version\_res (BTC)

M/O	PDU	Contents
M	LMP_version_req	VersNr Compld SubVersNr
M	LMP_version_res	VersNr Compld SubVersNr

Table 4.26: PDUs used for LMP version request

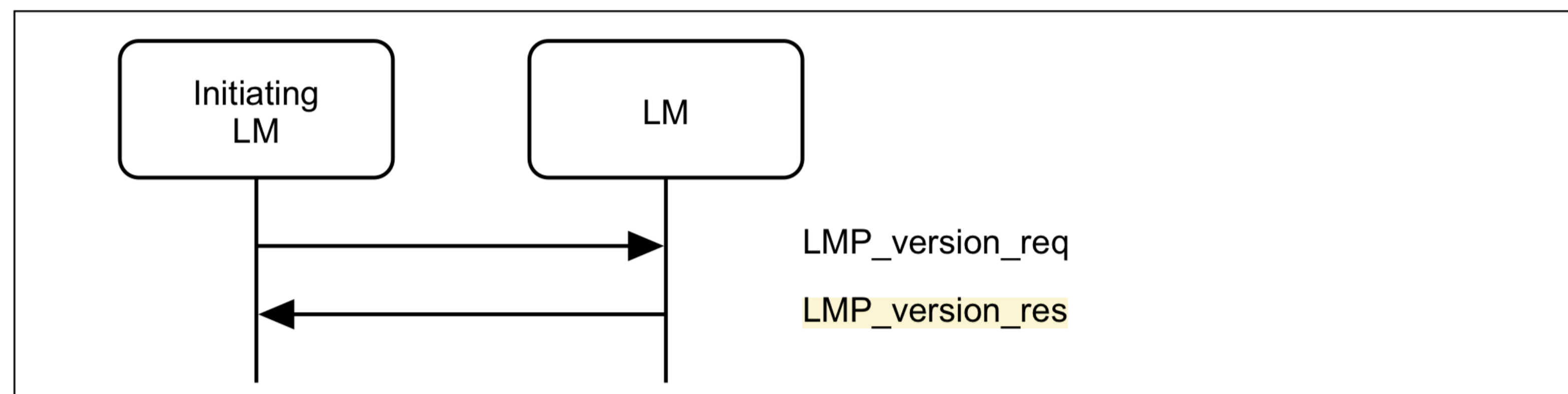

Sequence 77: Request for LMP version





# 2thprint by LL\_VERSION\_IND (BLE)

## 2.4.2.13 LL\_VERSION\_IND

The format of the CtrData field is shown in [Figure 2.23](#).

CtrData		
VersNr (1 octet)	Compld (2 octets)	SubVersNr (2 octets)

Figure 2.23: CtrData field of the LL\_VERSION\_IND PDU

The LL\_VERSION\_IND CtrData consists of three fields:

- VersNr field shall contain the version of the Bluetooth Controller specification (see Bluetooth [Assigned Numbers](#)).
- Compld field shall contain the company identifier of the manufacturer of the Bluetooth Controller (see Bluetooth [Assigned Numbers](#)).
- SubVersNr field shall contain a unique value for each implementation or revision of an implementation of the Bluetooth Controller.

# Prior Work

## "ESPwn32: Hacking with ESP32 System-on-Chips"

- Oh no! I got scooped! (Or did I?)
- [1] by Cayre et al. from May 2023 recognized that LL\_VERSION\_IND packets contains useful information
- But it subsequently *assumes* this information is *sufficient* for vulnerability applicability assessment, without offering any proof / data analysis

### Remote BLE stack fingerprinting !

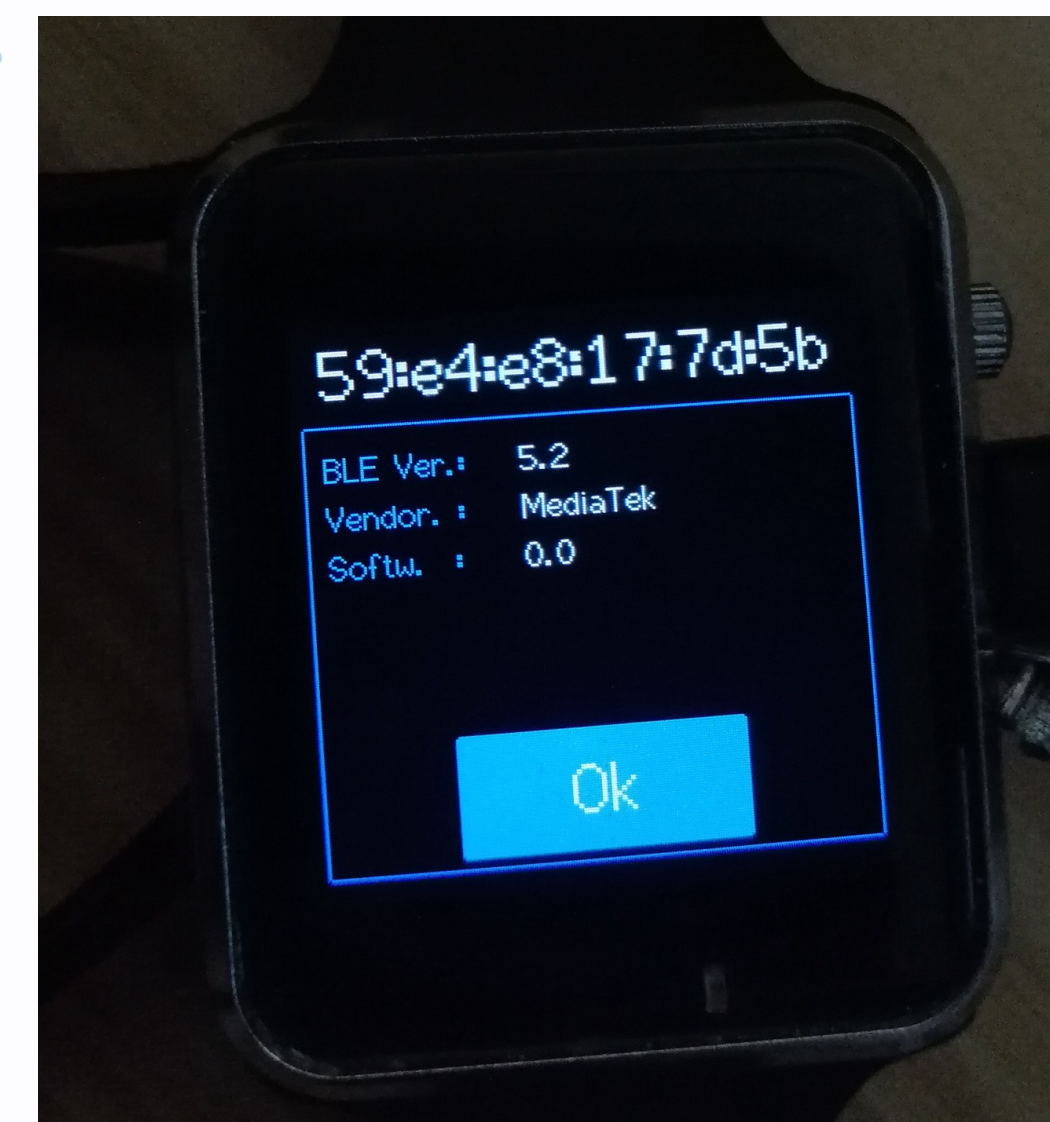

# Prior Work

## "ESPwn32: Hacking with ESP32 System-on-Chips"

- Oh no! I got scooped! (Or did I?)
- [1] by Cayre et al. from May 2023 recognized that LL\_VERSION\_IND packets contains useful information
- But it subsequently *assumes* this information is *sufficient* for vulnerability applicability assessment, without offering any proof / data analysis

### Remote BLE stack fingerprinting !





# LMP/LL 2thprints useful, but not definitive

- It turns out that for MediaTek (CID = 70), the most common value for the sub version is 0

device_BT_CID	lmp_sub_version	frequency
70	0	774
70	288	189
70	4648	86
70	4101	62
70	2051	15
70	1571	14
70	613	11
70	533	10
70	2344	10
70	1030	9
70	4391	8
70	1797	7
70	4135	5
70	304	4
70	726	4
70	791	4
70	1560	4
70	1817	4

device_BT_CID	ll_sub_version	frequency
70	0	36
70	534	8
70	4101	8
70	4648	6
70	2051	5
70	4355	3
70	4373	2
70	288	1
70	304	1
70	546	1
70	776	1
70	791	1
70	1033	1
70	1042	1
70	1045	1
70	1568	1
70	4097	1
70	4116	1



# LMP/LL 2thprints useful, but not definitive

- It turns out that for MediaTek (CID = 70), the most common value for the sub version is 0

device_BT_CID	lmp_sub_version	frequency
70	0	774
70	288	189
70	4648	86
70	4101	62
70	2051	15
70	1571	14
70	613	11
70	533	10
70	2344	10
70	1030	9
70	4391	8
70	1797	7
70	4135	5
70	304	4
70	726	4
70	791	4
70	1560	4
70	1817	4

device_BT_CID	ll_sub_version	frequency
70	0	36
70	534	8
70	4101	8
70	4648	6
70	2051	5
70	4355	3
70	4373	2
70	288	1
70	304	1
70	546	1
70	776	1
70	791	1
70	1033	1
70	1042	1
70	1045	1
70	1568	1
70	4097	1
70	4116	1



# LMP/LL 2thprints useful, but not definitive

- It turns out that for MediaTek (CID = 70), the most common value for the sub version is 0

device_BT_CID	lmp_sub_version	frequency
70	0	774
70	288	189
70	4648	86
70	4101	62
70	2051	15
70	1571	14
70	613	11
70	533	10
70	2344	10
70	1030	9
70	4391	8
70	1797	7
70	4135	5
70	304	4
70	726	4
70	791	4
70	1560	4
70	1817	4

device_BT_CID	ll_sub_version	frequency
70	0	36
70	534	8
70	4101	8
70	4648	6
70	2051	5
70	4355	3
70	4373	2
70	288	1
70	304	1
70	546	1
70	776	1
70	791	1
70	1033	1
70	1042	1
70	1045	1
70	1568	1
70	4097	1
70	4116	1



# OnePlus Pad

Halo Green | 8 GB RAM + 128 GB Storage

CA\$649.99

Color: Halo Green



ROM

8 GB RAM + 128 GB Storage



# out not definitive

most common value for the sub

70	4101	62
70	2051	15
70	1571	14
70	613	11
70	533	10
70	2344	10
70	1030	9
70	4391	8
70	1797	7
70	4135	5
70	304	4
70	726	4
70	791	4
70	1560	4
70	1817	4

device_BT_CID	ll_sub_version	frequency
70	0	36
70	534	8
70	4101	8
70	4648	6
70	2051	5
70	4355	3
70	4373	2
70	288	1
70	304	1
70	546	1
70	776	1
70	791	1
70	1033	1
70	1042	1
70	1045	1
70	1568	1
70	4097	1
70	4116	1





# OnePlus Pad

Halo Green | 8 GB RAM + 128 GB Storage

CA\$649.99

Color: Halo Green



ROM

8 GB RAM + 128 GB Storage



70	4101	62
70	2051	15
70	1571	14
70	613	11
70	533	10
70	2344	10
70	1030	9
70	4391	8
70	1797	7
70	4135	5
70	304	4
70	726	4
70	791	4
70	1560	4
70	1817	4



# OnePlus Pad

Halo Green | 8 GB RAM + 128 GB Storage

CA\$649.99

Color: Halo Green



ROM

8 GB RAM + 128 GB Storage

Nokia 130

Feed your playful side



62  
15  
14  
11  
10  
10  
9  
8  
7  
5  
4  
4  
4  
4  
4





# OnePlus Pad

Halo Green | 8 GB RAM + 128 GB Storage

CA\$649.99

Color: Halo Green



ROM

8 GB RAM + 128 GB Storage



Nokia 130  
Feed your playful side



62  
15  
14  
11  
10  
10  
9  
8  
7  
5  
4  
4  
4  
4  
4





# (Link Layer) Version Number

## VersNr (1 byte)

Last Modified: 2023-02-21

Core Specification Name	Version
Bluetooth® Core Specification 1.0b (Withdrawn)	0x00
Bluetooth® Core Specification 1.1 (Withdrawn)	0x01
Bluetooth® Core Specification 1.2 (Withdrawn)	0x02
Bluetooth® Core Specification 2.0+EDR (Withdrawn)	0x03
Bluetooth® Core Specification 2.1+EDR (Withdrawn)	0x04
Bluetooth® Core Specification 3.0+HS (Withdrawn)	0x05
Bluetooth® Core Specification 4.0 (Withdrawn)	0x06
Bluetooth® Core Specification 4.1 (Deprecated)	0x07
Bluetooth® Core Specification 4.2	0x08
Bluetooth® Core Specification 5.0	0x09
Bluetooth® Core Specification 5.1	0x0A
Bluetooth® Core Specification 5.2	0x0B
Bluetooth® Core Specification 5.3	0x0C
Bluetooth® Core Specification 5.4	0x0D

CtrData		
VersNr (1 octet)	Compld (2 octets)	SubVersNr (2 octets)

Figure 2.1: CtrData field of the LL\_VERSION\_IND PDU

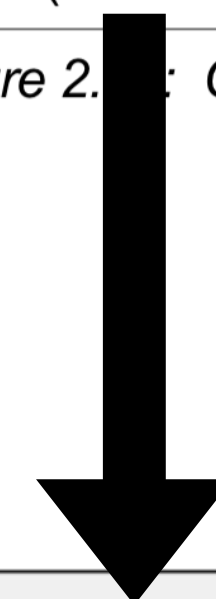

CtrData		
VersNr (1 octet)	Compld (2 octets)	SubVersNr (2 octets)

Figure 2.23: CtrData field in the LL\_VERSION\_IND PDU

# (Link Layer) Company Identifier

**Compld (2 bytes) - 3330 defined at time of writing**

company\_identifiers:

- value: 0x0CA5  
name: 'Princess Cruise Lines, Ltd.'
- value: 0x0CA4  
name: 'MITSUBISHI ELECTRIC LIGHTING CO, LTD'
- value: 0x0CA3  
name: 'MAQUET GmbH'
- value: 0x0CA2  
name: 'XSENSE LTD'
- value: 0x0CA1  
name: 'YAMAHA MOTOR CO.,LTD.'
- value: 0x0CA0  
name: 'BIGBEN'
- value: 0x0C9F  
name: 'Dragonfly Energy Corp.'
- value: 0x0C9E  
name: 'LEGCEL CORPORATION, SAS'

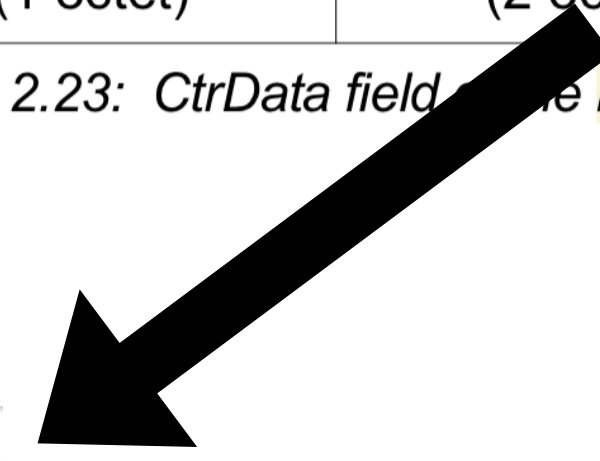

CtrData		
VersNr (1 octet)	Compld (2 octets)	SubVersNr (2 octets)

Figure 2.23: CtrData field of the LL\_VERSION\_IND PDU

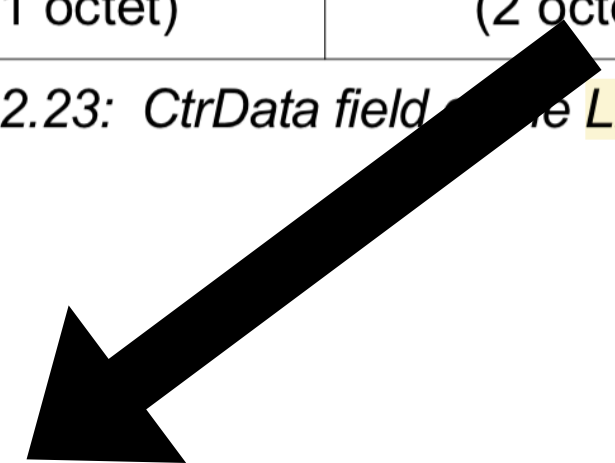

- name: 'H+B Hightech GmbH'
- value: 0x0C95  
name: 'Gemstone Lights Canada Ltd.'
- value: 0x0C94  
name: 'Baxter Healthcare Corporation'
- value: 0x0C93  
name: 'Movesense Oy'
- value: 0x0C92  
name: 'Kesseböhmer Ergonomietechnik GmbH'
- value: 0x0C91  
name: 'Yashu Systems'
- value: 0x0C90  
name: 'WESCO AG'
- value: 0x0C8F  
name: 'Radar Automobile Sales(Shandong)Co.,Ltd.'
- value: 0x0C8E  
name: 'Technocon Engineering Ltd.'
- value: 0x0C8D  
name: 'tonies GmbH'
- value: 0x0C8C  
name: 'T-Mobile USA'

# (Link Layer) Company Identifier

## Compld (2 bytes) - 3330 defined at time of writing

company\_identifiers:

- value: 0x0CA5  
name: 'Princess Cruise Lines, Ltd.'
- value: 0x0CA4  
name: 'MITSUBISHI ELECTRIC LIGHTING CO, LTD'
- value: 0x0CA3  
name: 'MAQUET GmbH'
- value: 0x0CA2  
name: 'XSENSE LTD'
- value: 0x0CA1  
name: 'YAMAHA MOTOR CO.,LTD.'
- value: 0x0CA0  
name: 'BIGBEN'
- value: 0x0C9F  
name: 'Dragonfly Energy Corp.'
- value: 0x0C9E

# (Link Layer) Company Identifier

## Compld (2 bytes) - 3330 defined at time of writing

company\_identifiers:

- value: 0x0CA5  
name: 'Princess Cruise Lines, Ltd.'
- value: 0x0CA4  
name: 'MITSUBISHI ELECTRIC LIGHTING CO, LTD'
- value: 0x0CA3  
name: 'MAQUET GmbH'
- value: 0x0CA2  
name: 'XSENSE LTD'
- value: 0x0CA1  
name: 'YAMAHA MOTOR CO.,LTD.'
- value: 0x0CA0  
name: 'BIGBEN'
- value: 0x0C9F  
name: 'Dragonfly Energy Corp.'
- value: 0x0C9E



# (Link Layer) Comparison

## Compld (2 bytes) - 3330 defined

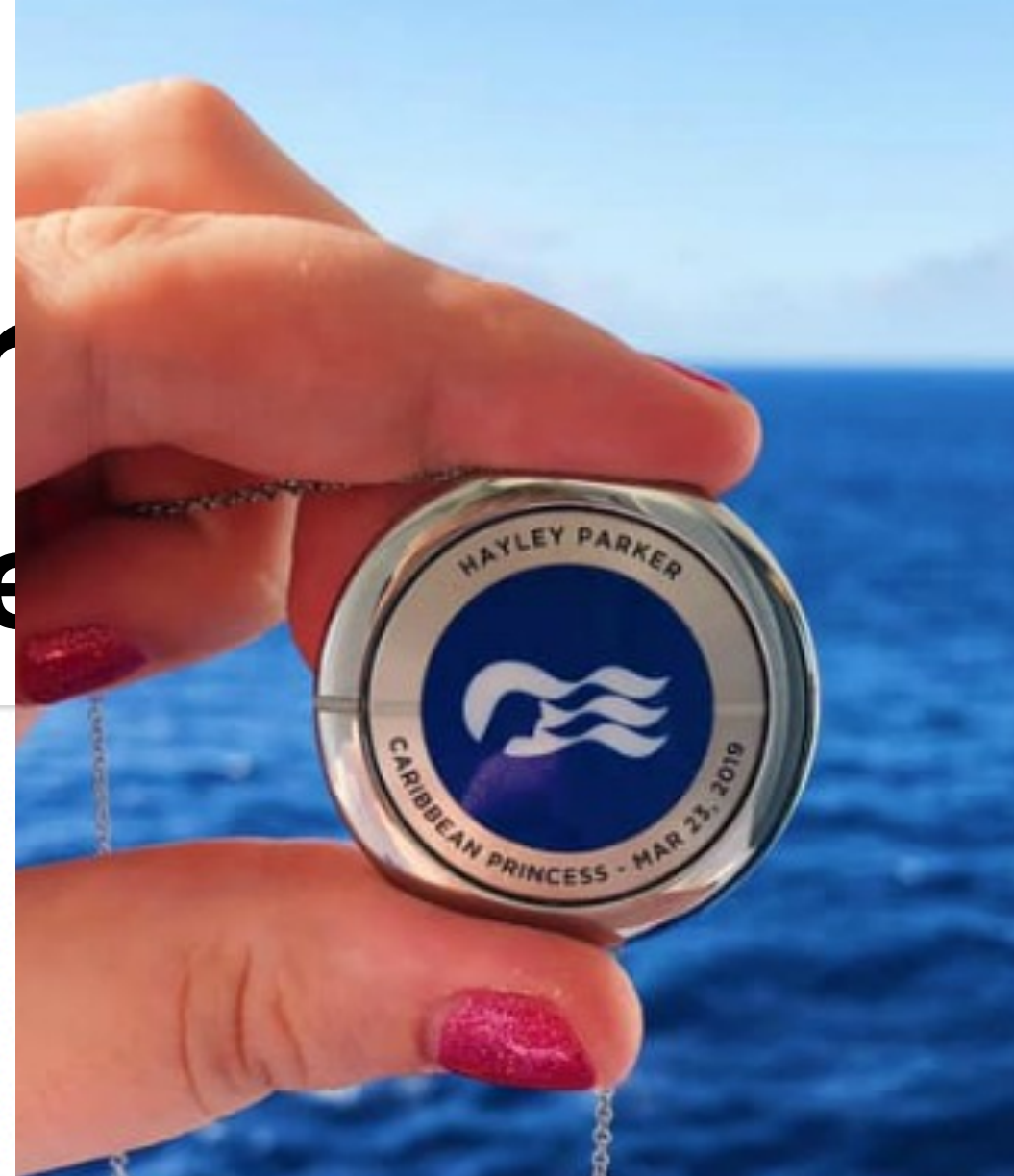

r  
iting

company\_identifiers:

- value: 0x0CA5  
name: 'Princess Cruise Lines, Ltd.'
- value: 0x0CA4  
name: 'MITSUBISHI ELECTRIC LIGHTING CO, LTD'
- value: 0x0CA3  
name: 'MAQUET GmbH'
- value: 0x0CA2  
name: 'XSENSE LTD'
- value: 0x0CA1  
name: 'YAMAHA MOTOR CO.,LTD.'
- value: 0x0CA0  
name: 'BIGBEN'
- value: 0x0C9F  
name: 'Dragonfly Energy Corp.'
- value: 0x0C9E

# (Link Layer) Comparison

## Compld (2 bytes) - 3330 defined

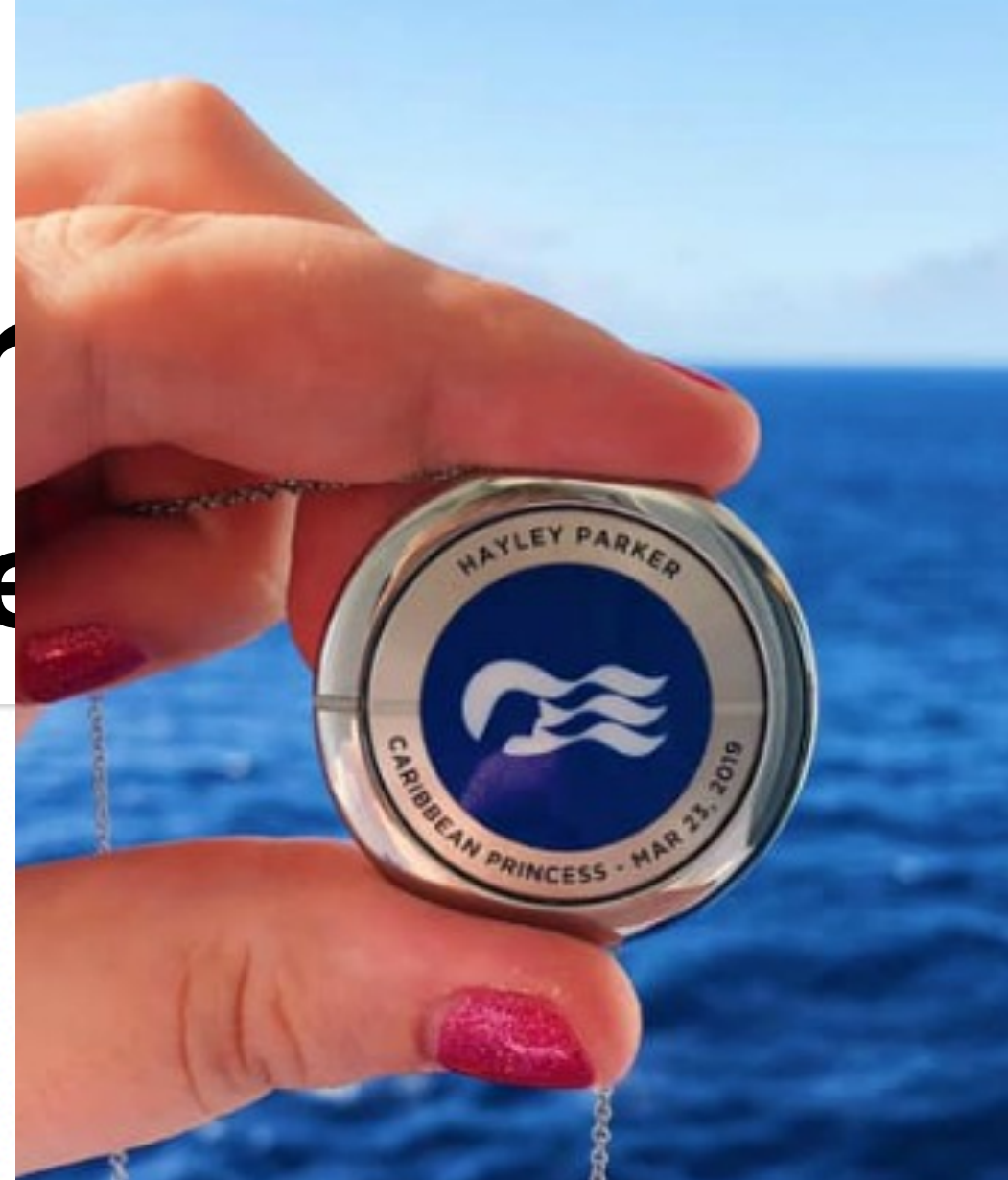

r  
iting

company\_identifiers:

- value: 0x0CA5  
name: 'Princess Cruise Lines, Ltd.'
- value: 0x0CA4  
name: 'MITSUBISHI ELECTRIC LIGHTING CO, LTD'
- value: 0x0CA3  
name: 'MAQUET GmbH'
- value: 0x0CA2  
name: 'XSENSE LTD'
- value: 0x0CA1  
name: 'YAMAHA MOTOR CO.,LTD.'
- value: 0x0CA0  
name: 'BIGBEN'
- value: 0x0C9F  
name: 'Dragonfly Energy Corp.'
- value: 0x0C9E

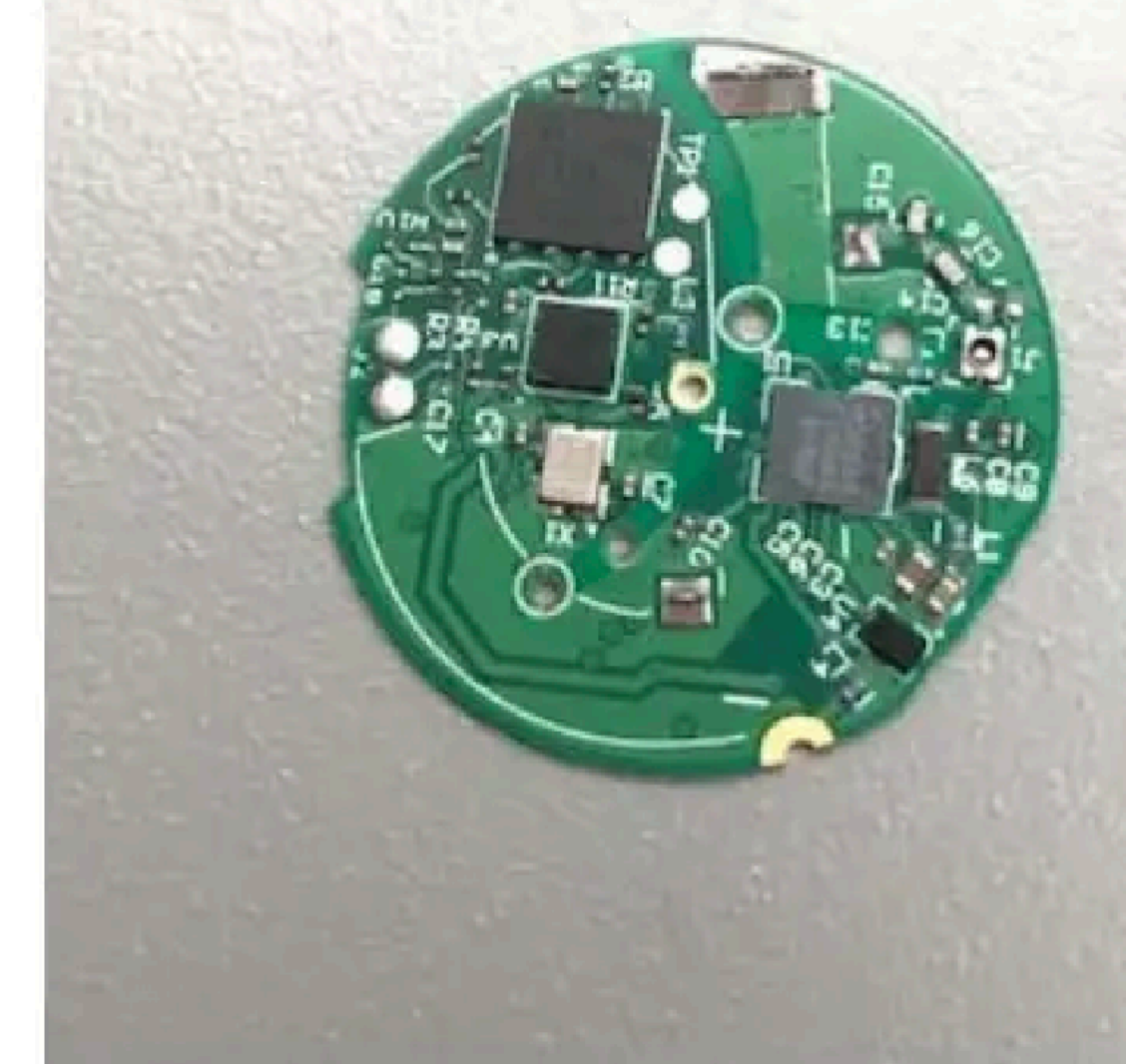

Top Side of PCB View

# (Link Layer) Comparison

Compld (2 bytes) - 3330 defined

company\_identifiers:



Writing

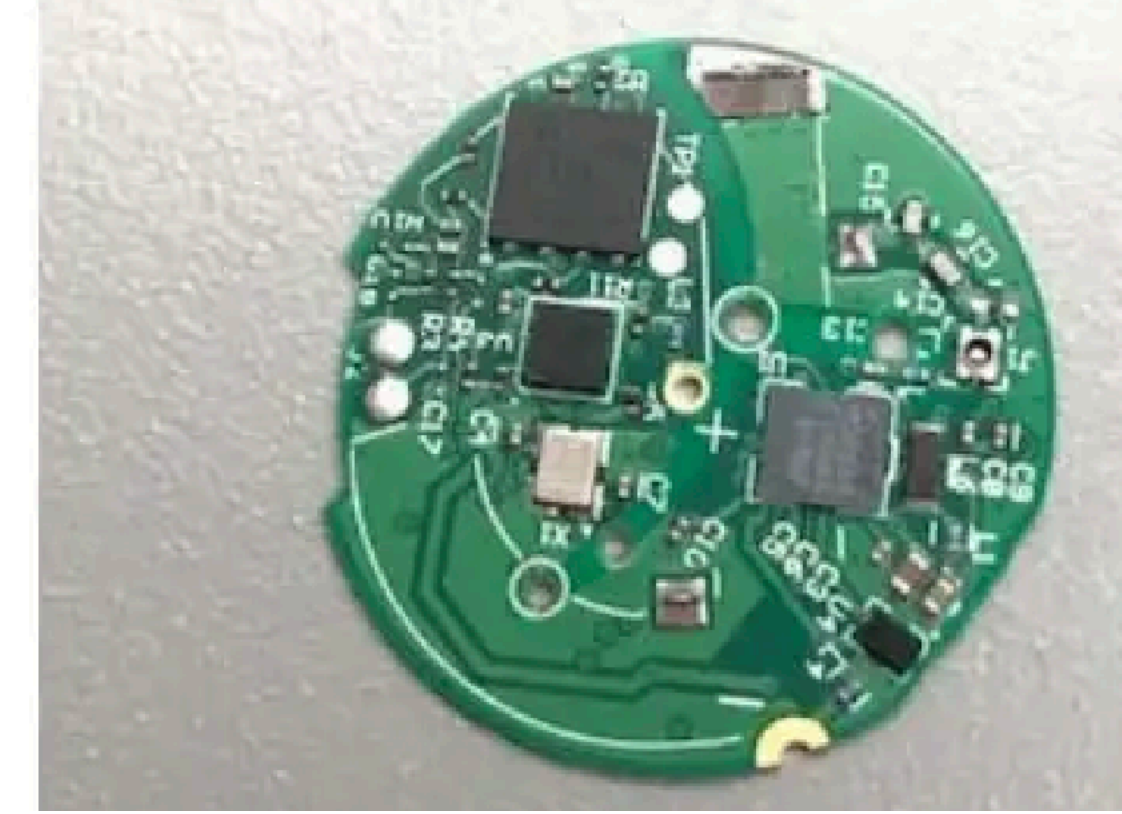

## Hands Full? No Problem

You walk along the corridor and voila! Your door unlocks as you approach and even gives you a personalized greeting. You'll enjoy keyless entry with automatic door locks every time you enter your stateroom.



# (Link Layer) Comparison

Compld (2 bytes) - 3330 defined

company\_identifiers:



Writing

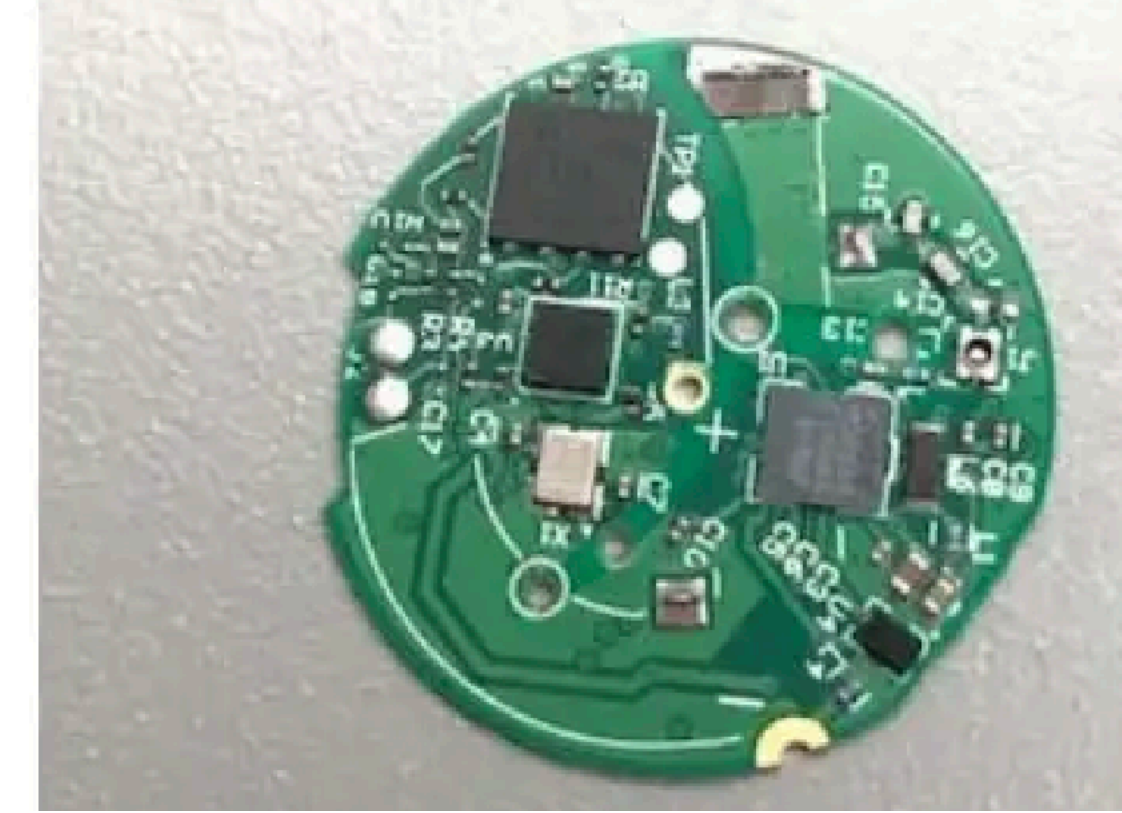

## Hands Full? No Problem

You walk along the corridor and voila! Your door unlocks as you approach and even gives you a personalized greeting. You'll enjoy keyless entry with automatic door locks every time you enter your stateroom.



# (Link Layer) Comparison

Compld (2 bytes) - 3330 defined

company\_identifiers:



Writing

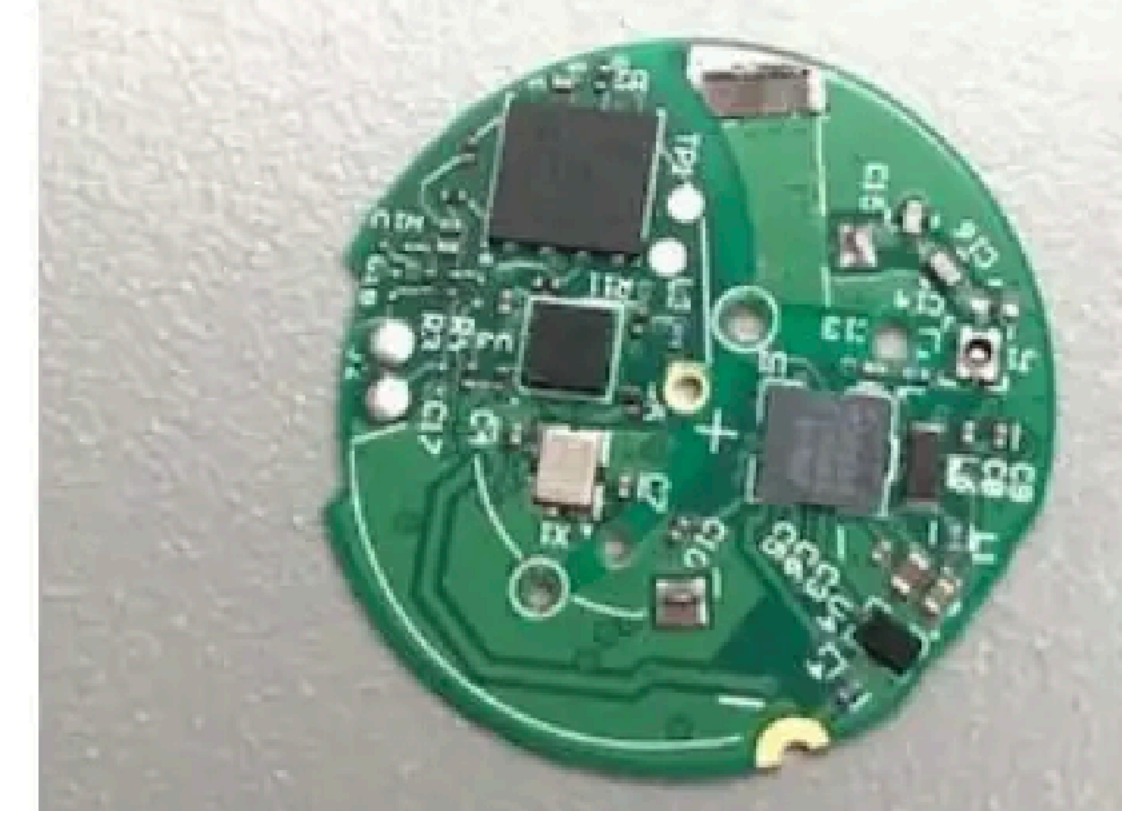

## Hands Full? No Problem

You walk along the corridor and voila! Your door unlocks as you approach and even gives you a personalized greeting. You'll enjoy keyless entry with automatic door locks every time you enter your stateroom.





# Vendor Prevalence

## BLE - 2023-10-26

- In general though this seems to have a higher prevalence of silicon makers than other BT company/vendor ID fields, so a better S/N ratio for what I want to know
- I have only seen ~ 11466 / 92854 (12.3%) success in my LL 2thprint log
  - Future work will take RSSI into account

comp_by_CompId	count
Broadcom Corporation	8108
Apple, Inc.	1466
Nordic Semiconductor ASA	163
Qualcomm Technologies International, Ltd. (QTIL)	121
MediaTek, Inc.	119
Qualcomm	114
Cypress Semiconductor	85
Texas Instruments Inc.	83
Samsung Electronics Co. Ltd.	60
Dialog Semiconductor B.V.	41
RivieraWaves S.A.S	32
Telink Semiconductor Co. Ltd	29
Bestechnic(Shanghai),Ltd	28
Realtek Semiconductor Corporation	28
ST Microelectronics	26
Marvell Technology Group Ltd.	19
Casambi Technologies Oy	15
Zhuhai Jieli technology Co.,Ltd	15
Airoha Technology Corp.	14
Silicon Laboratories	13
Ambiq	11
Atheros Communications, Inc.	10
Universal Electronics, Inc.	8
Shenzhen Goodix Technology Co., Ltd	6
Xinlin Microelectronics (Shenzhen) Co., Ltd	5



# Vendor Prevalence

**BLE - 2023-10-26**

- In general though this seems to have a higher prevalence of silicon makers than other BT company/vendor ID fields, so a better S/N ratio for what I want to know
- I have only seen ~ 11466 / 92854 (12.3%) success in my LL 2thprint log
  - Future work will take RSSI into account

comp_by_CompId	count
Broadcom Corporation	8108
Apple, Inc.	1466
Nordic Semiconductor ASA	163
Qualcomm Technologies International, Ltd. (QTIL)	121
MediaTek, Inc.	119
Qualcomm	114
Cypress Semiconductor	85
Texas Instruments Inc.	83
Samsung Electronics Co. Ltd.	60
Dialog Semiconductor B.V.	41
RivieraWaves S.A.S	32
Telink Semiconductor Co. Ltd	29
Bestechnic(Shanghai),Ltd	28
Realtek Semiconductor Corporation	28
ST Microelectronics	26
Marvell Technology Group Ltd.	19
Casambi Technologies Oy	15
Zhuhai Jieli technology Co.,Ltd	15
Airoha Technology Corp.	14
Silicon Laboratories	13
Ambiq	11
Atheros Communications, Inc.	10
Universal Electronics, Inc.	8
Shenzhen Goodix Technology Co., Ltd	6
Yichip Microelectronics (Hangzhou) Co.,Ltd.	5
UNKNOWN_COMP_BY_BT_CID	5
beken	5
Actions (Zhuhai) Technology Co., Limited	5
PHYPLUS Inc	4
Intel Corp.	4
Toshiba Corp.	3
Shanghai wuqi microelectronics Co.,Ltd	2
Barrot Technology Co.,Ltd.	2
Hong Kong HunterSun Electronic Limited	2
WuXi Vimicro	2
NXP B.V.	2
Ingchips Technology Co., Ltd.	2
LAPIS Semiconductor Co.,Ltd	2
Bluetrum Technology Co.,Ltd	2
ON Semiconductor	1
MindTree Ltd.	1



# Vendor Prevalence

## BTC - 2023-10-26

- In general though this seems to have a higher prevalence of silicon makers than other BT company/vendor ID fields, so a better S/N ratio for what I want to know
- I have only seen ~ 7916 / 25125 (31.5%) success in my LMP 2thprint log
  - Future work will take RSSI into account

comp_by_CompId	count
🍪 Qualcomm	35
🍪 MediaTek, Inc.	26
🍪 Broadcom Corporation	25
🍪 Intel Corp.	8
🍪 Qualcomm Technologies International, Ltd. (QTIL)	7
🍪 Zhuhai Jieli technology Co.,Ltd	7
🍪 Realtek Semiconductor Corporation	6
🍪 Cypress Semiconductor	3
🍪 Marvell Technology Group Ltd.	2
🍪 Samsung Electronics Co. Ltd.	2
🍪 RivieraWaves S.A.S	2
🍪 Bluegiga	1
❌ Equinix AG	1
❌ G-wearables inc.	1
❌ Anova Applied Electronics	1
🧩 Toshiba Corp.	1
🍪 Texas Instruments Inc.	1
❌ Lumens For Less, Inc	1
❌ Nokia Mobile Phones	1
🍪 Actions (Zhuhai) Technology Co., Limited	1
🧩 Shenzhen Feasycom Technology Co., Ltd.	1





# Vendor Prevalence

## BTC - 2023-10-26

- In general though this seems to have a higher prevalence of silicon makers than other BT company/vendor ID fields, so a better S/N ratio for what I want to know
- I have only seen ~ 7916 / 25125 (31.5%) success in my LMP 2thprint log
  - Future work will take RSSI into account

Bitflip!

comp_by_CompId	count
Qualcomm	35
MediaTek, Inc.	26
Broadcom Corporation	25
Intel Corp.	8
Qualcomm Technologies International, Ltd. (QTIL)	7
Zhuhai Jieli technology Co.,Ltd	7
Realtek Semiconductor Corporation	6
Cypress Semiconductor	3
Marvell Technology Group Ltd.	2
Samsung Electronics Co. Ltd.	2
RivieraWaves S.A.S	2
Bluegiga	1
Equinix AG	1
G-wearables inc.	1
Anova Applied Electronics	1
Toshiba Corp.	1
Texas Instruments Inc.	1
Lumens For Less, Inc	1
Nokia Mobile Phones	1
Actions (Zhuhai) Technology Co., Limited	1
Shenzhen Feasycom Technology Co., Ltd.	1

device_bdaddr	comp_by_bdaddr	VersNr	SubVersNr	CompId	comp_by_CompId	device_name
FE:86:B6:4F:FC:0D	UNKNOWN_COMP_BY_BDADDR	8	3120	5D0	Anova Applied Electronics	BT201-AUDIO
70:09:71:69:80:D1	Samsung Electronics Co.,Ltd	9	1005	47	Bluegiga	[TV] Samsung TU7000 50 TV
10:2C:6B:91:A8:F5	AMPAK Technology, Inc.	A	2306	F	Broadcom Corporation	Stream TV
10:2C:6B:99:75:63	AMPAK Technology, Inc.	A	6B06	F	Broadcom Corporation	Living Room
14:7D:DA:0F:66:E8	Apple, Inc.	9	4406	F	Broadcom Corporation	mbp
C0:97:27:1C:2C:6B	SAMSUNG ELECTRO-MECHANICS(THAILAND)	7	2304	F	Broadcom Corporation	[TV] Samsung 8 Series (65)
F8:04:2E:81:2F:33	SAMSUNG ELECTRO-MECHANICS(THAILAND)	7	2304	F	Broadcom Corporation	[TV] UN55JU650D
84:A4:66:BA:96:6D	Samsung Electronics Co.,Ltd	6	410E	F	Broadcom Corporation	[TV]Samsung LED55
6C:56:97:31:8E:DA	Amazon Technologies Inc.	8	2304	131	Cypress Semiconductor	Echo Show-2N2
2C:33:61:E6:E2:07	Apple, Inc.	B	240C	131	Cypress Semiconductor	apple's Keyboard
2C:33:61:E6:E2:07	Apple, Inc.	B	240C	131	Cypress Semiconductor	wkeybd_KPAL
FE:86:B6:4F:FC:0D	UNKNOWN_COMP_BY_BDADDR	8	3120	1D6	G-wearables inc.	BT201-AUDIO
AC:67:5D:CA:0A:8E	Intel Corporate	9	100	2	Intel Corp.	EXPCQ6092
C8:B2:9B:B0:25:83	Intel Corporate	B	216E	2	Intel Corp.	DESKTOP-EC66KUJ
00:42:38:F7:73:8E	Intel Corporate	B	2237	2	Intel Corp.	CVLAPTOP07
34:C9:3D:2D:B5:B2	Intel Corporate	B	226A	2	Intel Corp.	FCS00200079
AC:3F:A4:D2:3F:65	TAIYO YUDEN CO.,LTD	5	4633	48	Marvell Technology Group Ltd.	TJQLJ175205968
10:4E:89:69:FD:70	Garmin International	7	0	46	MediaTek, Inc.	BT_Garmin DriveSmart #3972245662
E8:9E:B4:18:AE:70	Hon Hai Precision Ind. Co.,Ltd.	6	928	46	MediaTek, Inc.	XBR-75X850E
E8:51:77:E8:C6:B9	Qingdao Intelligent&Precise Electronics Co.,Ltd.	A	12E4	46	MediaTek, Inc.	SmartTV 4K
70:09:71:34:21:95	Samsung Electronics Co.,Ltd	9	1005	46	MediaTek, Inc.	[TV] Samsung TU700D 50 TV
70:09:71:69:80:D1	Samsung Electronics Co.,Ltd	9	1005	46	MediaTek, Inc.	[TV] Samsung TU7000 50 TV
C0:23:8D:74:A2:EF	Samsung Electronics Co.,Ltd	9	1005	46	MediaTek, Inc.	[TV] Samsung Q60AA 65 TV
BC:7E:8B:2B:13:0D	Samsung Electronics Co.,Ltd	9	1228	46	MediaTek, Inc.	[TV] Samsung 7 Series (55)
00:7C:2D:29:B2:86	Samsung Electronics Co.,Ltd	9	308	46	MediaTek, Inc.	[TV] Samsung 7 Series (55)
D0:03:DF:D1:30:EF	Samsung Electronics Co.,Ltd	9	308	46	MediaTek, Inc.	[TV] Samsung 7 Series (43)
D4:9D:C0:96:1C:EF	Samsung Electronics Co.,Ltd	9	317	46	MediaTek, Inc.	[TV] Samsung 7 Series (50)
70:09:71:69:80:D1	Samsung Electronics Co.,Ltd	9	7003	46	MediaTek, Inc.	[TV] Samsung TU7000 50 TV
70:09:71:34:21:95	Samsung Electronics Co.,Ltd	9	7005	46	MediaTek, Inc.	[TV] Samsung TU700D 50 TV
4C:C9:5E:72:FE:93	Samsung Electronics Co.,Ltd	9	803	46	MediaTek, Inc.	[TV] Samsung 7 Series (43)
AC:67:5D:CA:0A:8E	Intel Corporate	9	100	1	Nokia Mobile Phones	EXPCQ6092
4C:CE:2D:1C:A7:BB	Danlaw Inc	7	25A	1D	Qualcomm	DL-2233301744
0C:02:BD:D3:05:67	Samsung Electronics Co.,Ltd	9	2BE	1D	Qualcomm	NULL
5C:C1:D7:3F:57:1B	Samsung Electronics Co.,Ltd	8	321	1D	Qualcomm	[TV] Samsung 6 Series (43)
5C:C1:D7:3F:5A:01	Samsung Electronics Co.,Ltd	8	321	1D	Qualcomm	[TV] Samsung 6 Series (43)
7C:64:56:B6:44:6F	Samsung Electronics Co.,Ltd	8	321	1D	Qualcomm	[TV] Samsung 6 Series (43)
7C:64:56:B6:44:75	Samsung Electronics Co.,Ltd	8	321	1D	Qualcomm	[TV] Samsung 6 Series (43)
D0:03:DF:EF:3A:CB	Samsung Electronics Co.,Ltd	8	321	1D	Qualcomm	[Refrigerator] Samsung
00:06:66:0B:E4:1D	Roving Networks	5	1A31	A	Qualcomm Technologies International, Ltd. (QTIL)	PLREP-E41D
88:E0:34:08:DF:FA	Shinwa industries(China) ltd.	8	2918	A	Qualcomm Technologies International, Ltd. (QTIL)	NULL
80:5E:0C:CC:1C:F8	YEALINK(XIAMEN) NETWORK TECHNOLOGY CO.,LTD.	8	2918	A	Qualcomm Technologies International, Ltd. (QTIL)	Yealink MP50
EC:9C:32:4F:A0:A2	Sichuan AI-Link Technology Co., Ltd.	7	7E1C	5D	Realtek Semiconductor Corporation	rk3328
C9:5C:04:77:9A:DD	UNKNOWN_COMP_BY_BDADDR	7	6AE6	5D	Realtek Semiconductor Corporation	BOOMBOX
DC:0D:30:F2:59:99	Shenzhen Feasycom Technology Co., Ltd.	9	6	A2D	Shenzhen Feasycom Technology Co., Ltd.	979869022455
14:8F:21:50:AB:18	Garmin International	6	1B5D	D	Texas Instruments Inc.	BT_nuvi #3912042869
7C:64:56:B6:44:6F	Samsung Electronics Co.,Ltd	8	6321	801D	UNKNOWN_COMP_BY_BT_CID	[TV] Samsung 6 Series (43)
BD:94:2C:C6:2D:74	UNKNOWN_COMP_BY_BDADDR	9	3520	39D6	UNKNOWN_COMP_BY_BT_CID	CAD-4057
B7:89:B9:E1:05:00	UNKNOWN_COMP_BY_BDADDR	9	3120	5D6	Zhuhai Jieli technology Co.,Ltd	CAD-6057
FE:86:B6:4F:FC:0D	UNKNOWN_COMP_BY_BDADDR	3	3120	5D6	Zhuhai Jieli technology Co.,Ltd	BT201-AUDIO
FE:86:B6:4F:FC:0D	UNKNOWN_COMP_BY_BDADDR	8	3120	5D6	Zhuhai Jieli technology Co.,Ltd	BT201-AUDIO

# Example Data

device_bdaddr	comp_by_bdaddr	VersNr	SubVersNr	CompId	comp_by_CompId	device_name
FE:86:B6:4F:FC:0D	UNKNOWN_COMP_BY_BDADDR	8	3120	5D0	Anova Applied Electronics	BT201-AUDIO
70:09:71:69:80:D1	Samsung Electronics Co.,Ltd	9	1005	47	Bluegiga	[TV] Samsung TU7000 50 TV
10:2C:6B:91:A8:F5	AMPAK Technology, Inc.	A	2306	F	Broadcom Corporation	Stream TV
10:2C:6B:99:75:63	AMPAK Technology, Inc.	A	6B06	F	Broadcom Corporation	Living Room
14:7D:DA:0F:66:E8	Apple, Inc.	9	4406	F	Broadcom Corporation	mbp
C0:97:27:1C:2C:6B	SAMSUNG ELECTRO-MECHANICS(THAILAND)	7	2304	F	Broadcom Corporation	[TV] Samsung 8 Series (65)
F8:04:2E:81:2F:33	SAMSUNG ELECTRO-MECHANICS(THAILAND)	7	2304	F	Broadcom Corporation	[TV] UN55JU650D
84:A4:66:BA:96:6D	Samsung Electronics Co.,Ltd	6	410E	F	Broadcom Corporation	[TV]Samsung LED55
6C:56:97:31:8E:DA	Amazon Technologies Inc.	8	2304	131	Cypress Semiconductor	Echo Show-2N2
2C:33:61:E6:E2:07	Apple, Inc.	B	240C	131	Cypress Semiconductor	apple's Keyboard
2C:33:61:E6:E2:07	Apple, Inc.	B	240C	131	Cypress Semiconductor	wkeybd_KPAL
FE:86:B6:4F:FC:0D	UNKNOWN_COMP_BY_BDADDR	8	3120	1D6	G-wearables inc.	BT201-AUDIO
AC:67:5D:CA:0A:8E	Intel Corporate	9	100	2	Intel Corp.	EXPCQ6092
C8:B2:9B:B0:25:83	Intel Corporate	B	216E	2	Intel Corp.	DESKTOP-EC66KUJ
00:42:38:F7:73:8E	Intel Corporate	B	2237	2	Intel Corp.	CVLAPTOP07
34:C9:3D:2D:B5:B2	Intel Corporate	B	226A	2	Intel Corp.	FCS00200079
AC:3F:A4:D2:3F:65	TAIYO YUDEN CO.,LTD	5	4633	48	Marvell Technology Group Ltd.	TJQLJ175205968
10:4E:89:69:FD:70	Garmin International	7	0	46	MediaTek, Inc.	BT_Garmin DriveSmart #3972245662
E8:9E:B4:18:AE:70	Hon Hai Precision Ind. Co.,Ltd.	6	928	46	MediaTek, Inc.	XBR-75X850E
E8:51:77:E8:C6:B9	Qingdao Intelligent&Precise Electronics Co.,Ltd.	A	12E4	46	MediaTek, Inc.	SmartTV 4K
70:09:71:34:21:95	Samsung Electronics Co.,Ltd	9	1005	46	MediaTek, Inc.	[TV] Samsung TU700D 50 TV
70:09:71:69:80:D1	Samsung Electronics Co.,Ltd	9	1005	46	MediaTek, Inc.	[TV] Samsung TU7000 50 TV
C0:23:8D:74:A2:EF	Samsung Electronics Co.,Ltd	9	1005	46	MediaTek, Inc.	[TV] Samsung Q60AA 65 TV
BC:7E:8B:2B:13:0D	Samsung Electronics Co.,Ltd	9	1228	46	MediaTek, Inc.	[TV] Samsung 7 Series (55)
00:7C:2D:29:B2:86	Samsung Electronics Co.,Ltd	9	308	46	MediaTek, Inc.	[TV] Samsung 7 Series (55)
D0:03:DF:D1:30:EF	Samsung Electronics Co.,Ltd	9	308	46	MediaTek, Inc.	[TV] Samsung 7 Series (43)
D4:9D:C0:96:1C:EF	Samsung Electronics Co.,Ltd	9	317	46	MediaTek, Inc.	[TV] Samsung 7 Series (50)
70:09:71:69:80:D1	Samsung Electronics Co.,Ltd	9	7003	46	MediaTek, Inc.	[TV] Samsung TU7000 50 TV
70:09:71:34:21:95	Samsung Electronics Co.,Ltd	9	7005	46	MediaTek, Inc.	[TV] Samsung TU700D 50 TV
4C:C9:5E:72:FE:93	Samsung Electronics Co.,Ltd	9	803	46	MediaTek, Inc.	[TV] Samsung 7 Series (43)
AC:67:5D:CA:0A:8E	Intel Corporate	9	100	1	Nokia Mobile Phones	EXPCQ6092
4C:CE:2D:1C:A7:BB	Danlaw Inc	7	25A	1D	Qualcomm	DL-2233301744
0C:02:BD:D3:05:67	Samsung Electronics Co.,Ltd	9	2BE	1D	Qualcomm	NULL
5C:C1:D7:3F:57:1B	Samsung Electronics Co.,Ltd	8	321	1D	Qualcomm	[TV] Samsung 6 Series (43)
5C:C1:D7:3F:5A:01	Samsung Electronics Co.,Ltd	8	321	1D	Qualcomm	[TV] Samsung 6 Series (43)
7C:64:56:B6:44:6F	Samsung Electronics Co.,Ltd	8	321	1D	Qualcomm	[TV] Samsung 6 Series (43)
7C:64:56:B6:44:75	Samsung Electronics Co.,Ltd	8	321	1D	Qualcomm	[TV] Samsung 6 Series (43)
D0:03:DF:EF:3A:CB	Samsung Electronics Co.,Ltd	8	321	1D	Qualcomm	[Refrigerator] Samsung
00:06:66:0B:E4:1D	Roving Networks	5	1A31	A	Qualcomm Technologies International, Ltd. (QTIL)	PLREP-E41D
88:E0:34:08:DF:FA	Shinwa industries(China) ltd.	8	2918	A	Qualcomm Technologies International, Ltd. (QTIL)	NULL
80:5E:0C:CC:1C:F8	YEALINK(XIAMEN) NETWORK TECHNOLOGY CO.,LTD.	8	2918	A	Qualcomm Technologies International, Ltd. (QTIL)	Yealink MP50
EC:9C:32:4F:A0:A2	Sichuan AI-Link Technology Co., Ltd.	7	7E1C	5D	Realtek Semiconductor Corporation	rk3328
C9:5C:04:77:9A:DD	UNKNOWN_COMP_BY_BDADDR	7	6AE6	5D	Realtek Semiconductor Corporation	BOOMBOX
DC:0D:30:F2:59:99	Shenzhen Feasycom Technology Co., Ltd.	9	6	A2D	Shenzhen Feasycom Technology Co., Ltd.	979869022455
14:8F:21:50:AB:18	Garmin International	6	1B5D	D	Texas Instruments Inc.	BT_nuvi #3912042869
7C:64:56:B6:44:6F	Samsung Electronics Co.,Ltd	8	6321	801D	UNKNOWN_COMP_BY_BT_CID	[TV] Samsung 6 Series (43)
BD:94:2C:C6:2D:74	UNKNOWN_COMP_BY_BDADDR	9	3520	39D6	UNKNOWN_COMP_BY_BT_CID	CAD-4057
B7:89:B9:E1:05:00	UNKNOWN_COMP_BY_BDADDR	9	3120	5D6	Zhuhai Jieli technology Co.,Ltd	CAD-6057
FE:86:B6:4F:FC:0D	UNKNOWN_COMP_BY_BDADDR	3	3120	5D6	Zhuhai Jieli technology Co.,Ltd	BT201-AUDIO
FE:86:B6:4F:FC:0D	UNKNOWN_COMP_BY_BDADDR	8	3120	5D6	Zhuhai Jieli technology Co.,Ltd	BT201-AUDIO

# Example Data

device_bdaddr	comp_by_bdaddr	VersNr	SubVersNr	CompId	comp_by_CompId	device_name
FE:86:B6:4F:FC:0D	UNKNOWN_COMP_BY_BDADDR	8	3120	5D0	Anova Applied Electronics	BT201-AUDIO
70:09:71:69:80:D1	Samsung Electronics Co.,Ltd	9	1005	47	Bluegiga	[TV] Samsung TU7000 50 TV
10:2C:6B:91:A8:F5	AMPAK Technology, Inc.	A	2306	F	Broadcom Corporation	Stream TV
10:2C:6B:99:75:63	AMPAK Technology, Inc.	A	6B06	F	Broadcom Corporation	Living Room
14:7D:DA:0F:66:E8	Apple, Inc.	9	4406	F	Broadcom Corporation	mbp
C0:97:27:1C:2C:6B	SAMSUNG ELECTRO-MECHANICS(THAILAND)	7	2304	F	Broadcom Corporation	[TV] Samsung 8 Series (65)
F8:04:2E:81:2F:33	SAMSUNG ELECTRO-MECHANICS(THAILAND)	7	2304	F	Broadcom Corporation	[TV] UN55JU650D
84:A4:66:BA:96:6D	Samsung Electronics Co.,Ltd	6	410E	F	Broadcom Corporation	[TV]Samsung LED55
6C:56:97:31:8E:DA	Amazon Technologies Inc.	8	2304	131	Cypress Semiconductor	Echo Show-2N2
2C:33:61:E6:E2:07	Apple, Inc.	B	240C	131	Cypress Semiconductor	apple's Keyboard
2C:33:61:E6:E2:07	Apple, Inc.	B	240C	131	Cypress Semiconductor	ukeybd_KPAL
FE:86:B6:4F:FC:0D	UNKNOWN_COMP_BY_BDADDR	8	3120	1D6	G-wearables inc.	BT201-AUDIO
AC:67:5D:CA:0A:8E	Intel Corporate	9	100	2	Intel Corp.	EXPCQ6092
C8:B2:9B:B0:25:83	Intel Corporate	B	216E	2	Intel Corp.	DESKTOP-EC66KUJ
00:42:38:F7:73:8E	Intel Corporate	B	2237	2	Intel Corp.	CVLAPTOP07
34:C9:3D:2D:B5:B2	Intel Corporate	B	226A	2	Intel Corp.	FCS00200079
AC:3F:A4:D2:3F:65	TAIYO YUDEN CO.,LTD	5	4633	48	Marvell Technology Group Ltd.	TJQLJ175205968
10:4E:89:69:FD:70	Garmin International	7	0	46	MediaTek, Inc.	BT_Garmin DriveSmart #3972245662
E8:9E:B4:18:AE:70	Hon Hai Precision Ind. Co.,Ltd.	6	928	46	MediaTek, Inc.	XBR-75X850E
E8:51:77:E8:C6:B9	Qingdao Intelligent&Precise Electronics Co.,Ltd.	A	12E4	46	MediaTek, Inc.	SmartTV 4K
70:09:71:34:21:95	Samsung Electronics Co.,Ltd	9	1005	46	MediaTek, Inc.	[TV] Samsung TU700D 50 TV
70:09:71:69:80:D1	Samsung Electronics Co.,Ltd	9	1005	46	MediaTek, Inc.	[TV] Samsung TU7000 50 TV
C0:23:8D:74:A2:EF	Samsung Electronics Co.,Ltd	9	1005	46	MediaTek, Inc.	[TV] Samsung Q60AA 65 TV
BC:7E:8B:2B:13:0D	Samsung Electronics Co.,Ltd	9	1228	46	MediaTek, Inc.	[TV] Samsung 7 Series (55)
00:7C:2D:29:B2:86	Samsung Electronics Co.,Ltd	9	308	46	MediaTek, Inc.	[TV] Samsung 7 Series (55)
D0:03:DF:D1:30:EF	Samsung Electronics Co.,Ltd	9	308	46	MediaTek, Inc.	[TV] Samsung 7 Series (43)
D4:9D:C0:96:1C:EF	Samsung Electronics Co.,Ltd	9	317	46	MediaTek, Inc.	[TV] Samsung 7 Series (50)
70:09:71:69:80:D1	Samsung Electronics Co.,Ltd	9	7003	46	MediaTek, Inc.	[TV] Samsung TU7000 50 TV
70:09:71:34:21:95	Samsung Electronics Co.,Ltd	9	7005	46	MediaTek, Inc.	[TV] Samsung TU700D 50 TV
4C:C9:5E:72:FE:93	Samsung Electronics Co.,Ltd	9	803	46	MediaTek, Inc.	[TV] Samsung 7 Series (43)
AC:67:5D:CA:0A:8E	Intel Corporate	9	100	1	Nokia Mobile Phones	EXPCQ6092
4C:CE:2D:1C:A7:BB	Danlaw Inc	7	25A	1D	Qualcomm	DL-2233301744
0C:02:BD:D3:05:67	Samsung Electronics Co.,Ltd	9	2BE	1D	Qualcomm	NULL
5C:C1:D7:3F:57:1B	Samsung Electronics Co.,Ltd	8	321	1D	Qualcomm	[TV] Samsung 6 Series (43)
5C:C1:D7:3F:5A:01	Samsung Electronics Co.,Ltd	8	321	1D	Qualcomm	[TV] Samsung 6 Series (43)
7C:64:56:B6:44:6F	Samsung Electronics Co.,Ltd	8	321	1D	Qualcomm	[TV] Samsung 6 Series (43)
7C:64:56:B6:44:75	Samsung Electronics Co.,Ltd	8	321	1D	Qualcomm	[TV] Samsung 6 Series (43)
D0:03:DF:EF:3A:CB	Samsung Electronics Co.,Ltd	8	321	1D	Qualcomm	[Refrigerator] Samsung
00:06:66:0B:E4:1D	Roving Networks	5	1A31	A	Qualcomm Technologies International, Ltd. (QTIL)	PLREP-E41D
88:E0:34:08:DF:FA	Shinwa industries(China) ltd.	8	2918	A	Qualcomm Technologies International, Ltd. (QTIL)	NULL
80:5E:0C:CC:1C:F8	YEALINK(XIAMEN) NETWORK TECHNOLOGY CO.,LTD.	8	2918	A	Qualcomm Technologies International, Ltd. (QTIL)	Yealink MP50
EC:9C:32:4F:A0:A2	Sichuan AI-Link Technology Co., Ltd.	7	7E1C	5D	Realtek Semiconductor Corporation	rk3328
C9:5C:04:77:9A:DD	UNKNOWN_COMP_BY_BDADDR	7	6AE6	5D	Realtek Semiconductor Corporation	BOOMBOX
DC:0D:30:F2:59:99	Shenzhen Feasycom Technology Co., Ltd.	9	6	A2D	Shenzhen Feasycom Technology Co., Ltd.	979869022455
14:8F:21:50:AB:18	Garmin International	6	1B5D	D	Texas Instruments Inc.	BT_nuvi #3912042869
7C:64:56:B6:44:6F	Samsung Electronics Co.,Ltd	8	6321	801D	UNKNOWN_COMP_BY_BT_CID	[TV] Samsung 6 Series (43)
BD:94:2C:C6:2D:74	UNKNOWN_COMP_BY_BDADDR	9	3520	39D6	UNKNOWN_COMP_BY_BT_CID	CAD-4057
B7:89:B9:E1:05:00	UNKNOWN_COMP_BY_BDADDR	9	3120	5D6	Zhuhai Jieli technology Co.,Ltd	CAD-6057
FE:86:B6:4F:FC:0D	UNKNOWN_COMP_BY_BDADDR	3	3120	5D6	Zhuhai Jieli technology Co.,Ltd	BT201-AUDIO
FE:86:B6:4F:FC:0D	UNKNOWN_COMP_BY_BDADDR	8	3120	5D6	Zhuhai Jieli technology Co.,Ltd	BT201-AUDIO

# Example Data

device_bdaddr	comp_by_bdaddr	VersNr	SubVersNr	CompId	comp_by_CompId	device_name
FE:86:B6:4F:FC:0D	UNKNOWN_COMP_BY_BDADDR	8	3120	5D0	Anova Applied Electronics	BT201-AUDIO
70:09:71:69:80:D1	Samsung Electronics Co.,Ltd	9	1005	47	Bluegiga	[TV] Samsung TU7000 50 TV
10:2C:6B:91:A8:F5	AMPAK Technology, Inc.	A	2306	F	Broadcom Corporation	Stream TV
10:2C:6B:99:75:63	AMPAK Technology, Inc.	A	6B06	F	Broadcom Corporation	Living Room
14:7D:DA:0F:66:E8	Apple, Inc.	9	4406	F	Broadcom Corporation	mbp
C0:97:27:1C:2C:6B	SAMSUNG ELECTRO-MECHANICS(THAILAND)	7	2304	F	Broadcom Corporation	[TV] Samsung 8 Series (65)
F8:04:2E:81:2F:33	SAMSUNG ELECTRO-MECHANICS(THAILAND)	7	2304	F	Broadcom Corporation	[TV] UN55JU650D
84:A4:66:BA:96:6D	Samsung Electronics Co.,Ltd	6	410E	F	Broadcom Corporation	[TV]Samsung LED55
6C:56:97:31:8E:DA	Amazon Technologies Inc.	8	2304	131	Cypress Semiconductor	Echo Show-2N2
2C:33:61:E6:E2:07	Apple, Inc.	B	240C	131	Cypress Semiconductor	apple's Keyboard
2C:33:61:E6:E2:07	Apple, Inc.	B	240C	131	Cypress Semiconductor	ukeybd_KPAL
FE:86:B6:4F:FC:0D	UNKNOWN_COMP_BY_BDADDR	8	3120	1D6	G-wearables inc.	BT201-AUDIO
AC:67:5D:CA:0A:8E	Intel Corporate	9	100	2	Intel Corp.	EXPCQ6092
C8:B2:9B:B0:25:83	Intel Corporate	B	216E	2	Intel Corp.	DESKTOP-EC66KUJ
00:42:38:F7:73:8E	Intel Corporate	B	2237	2	Intel Corp.	CVLAPTOP07
34:C9:3D:2D:B5:B2	Intel Corporate	B	226A	2	Intel Corp.	FCS00200079
AC:3F:A4:D2:3F:65	TAIYO YUDEN CO.,LTD	5	4633	48	Marvell Technology Group Ltd.	TJQLJ175205968
10:4E:89:69:FD:70	Garmin International	7	0	46	MediaTek, Inc.	BT_Garmin DriveSmart #3972245662
E8:9E:B4:18:AE:70	Hon Hai Precision Ind. Co.,Ltd.	6	928	46	MediaTek, Inc.	XBR-75X850E
E8:51:77:E8:C6:B9	Qingdao Intelligent&Precise Electronics Co.,Ltd.	A	12E4	46	MediaTek, Inc.	SmartTV 4K
70:09:71:34:21:95	Samsung Electronics Co.,Ltd	9	1005	46	MediaTek, Inc.	[TV] Samsung TU700D 50 TV
70:09:71:69:80:D1	Samsung Electronics Co.,Ltd	9	1005	46	MediaTek, Inc.	[TV] Samsung TU7000 50 TV
C0:23:8D:74:A2:EF	Samsung Electronics Co.,Ltd	9	1005	46	MediaTek, Inc.	[TV] Samsung Q60AA 65 TV
BC:7E:8B:2B:13:0D	Samsung Electronics Co.,Ltd	9	1228	46	MediaTek, Inc.	[TV] Samsung 7 Series (55)
00:7C:2D:29:B2:86	Samsung Electronics Co.,Ltd	9	308	46	MediaTek, Inc.	[TV] Samsung 7 Series (55)
D0:03:DF:D1:30:EF	Samsung Electronics Co.,Ltd	9	308	46	MediaTek, Inc.	[TV] Samsung 7 Series (43)
D4:9D:C0:96:1C:EF	Samsung Electronics Co.,Ltd	9	317	46	MediaTek, Inc.	[TV] Samsung 7 Series (50)
70:09:71:69:80:D1	Samsung Electronics Co.,Ltd	9	7003	46	MediaTek, Inc.	[TV] Samsung TU7000 50 TV
70:09:71:34:21:95	Samsung Electronics Co.,Ltd	9	7005	46	MediaTek, Inc.	[TV] Samsung TU700D 50 TV
4C:C9:5E:72:FE:93	Samsung Electronics Co.,Ltd	9	803	46	MediaTek, Inc.	[TV] Samsung 7 Series (43)
AC:67:5D:CA:0A:8E	Intel Corporate	9	100	1	Nokia Mobile Phones	EXPCQ6092
4C:CE:2D:1C:A7:BB	Danlaw Inc	7	25A	1D	Qualcomm	DL-2233301744
0C:02:BD:D3:05:67	Samsung Electronics Co.,Ltd	9	2BE	1D	Qualcomm	NULL
5C:C1:D7:3F:57:1B	Samsung Electronics Co.,Ltd	8	321	1D	Qualcomm	[TV] Samsung 6 Series (43)
5C:C1:D7:3F:5A:01	Samsung Electronics Co.,Ltd	8	321	1D	Qualcomm	[TV] Samsung 6 Series (43)
7C:64:56:B6:44:6F	Samsung Electronics Co.,Ltd	8	321	1D	Qualcomm	[TV] Samsung 6 Series (43)
7C:64:56:B6:44:75	Samsung Electronics Co.,Ltd	8	321	1D	Qualcomm	[TV] Samsung 6 Series (43)
D0:03:DF:EF:3A:CB	Samsung Electronics Co.,Ltd	8	321	1D	Qualcomm	[Refrigerator] Samsung
00:06:66:0B:E4:1D	Roving Networks	5	1A31	A	Qualcomm Technologies International, Ltd. (QTIL)	PLREP-E41D
88:E0:34:08:DF:FA	Shinwa industries(China) ltd.	8	2918	A	Qualcomm Technologies International, Ltd. (QTIL)	NULL
80:5E:0C:CC:1C:F8	YEALINK(XIAMEN) NETWORK TECHNOLOGY CO.,LTD.	8	2918	A	Qualcomm Technologies International, Ltd. (QTIL)	Yealink MP50
EC:9C:32:4F:A0:A2	Sichuan AI-Link Technology Co., Ltd.	7	7E1C	5D	Realtek Semiconductor Corporation	rk3328
C9:5C:04:77:9A:DD	UNKNOWN_COMP_BY_BDADDR	7	6AE6	5D	Realtek Semiconductor Corporation	BOOMBOX
DC:0D:30:F2:59:99	Shenzhen Feasycom Technology Co., Ltd.	9	6	A2D	Shenzhen Feasycom Technology Co., Ltd.	979869022455
14:8F:21:50:AB:18	Garmin International	6	1B5D	D	Texas Instruments Inc.	BT_nuvi #3912042869
7C:64:56:B6:44:6F	Samsung Electronics Co.,Ltd	8	6321	801D	UNKNOWN_COMP_BY_BT_CID	[TV] Samsung 6 Series (43)
BD:94:2C:C6:2D:74	UNKNOWN_COMP_BY_BDADDR	9	3520	39D6	UNKNOWN_COMP_BY_BT_CID	CAD-4057
B7:89:B9:E1:05:00	UNKNOWN_COMP_BY_BDADDR	9	3120	5D6	Zhuhai Jieli technology Co.,Ltd	CAD-6057
FE:86:B6:4F:FC:0D	UNKNOWN_COMP_BY_BDADDR	3	3120	5D6	Zhuhai Jieli technology Co.,Ltd	BT201-AUDIO
FE:86:B6:4F:FC:0D	UNKNOWN_COMP_BY_BDADDR	8	3120	5D6	Zhuhai Jieli technology Co.,Ltd	BT201-AUDIO

# Example Data

device_bdaddr	comp_by_bdaddr	VersNr	SubVersNr	CompId	comp_by_CompId	device_name
FE:86:B6:4F:FC:0D	UNKNOWN_COMP_BY_BDADDR	8	3120	5D0	Anova Applied Electronics	BT201-AUDIO
70:09:71:69:80:D1	Samsung Electronics Co.,Ltd	9	1005	47	Bluegiga	[TV] Samsung TU7000 50 TV
10:2C:6B:91:A8:F5	AMPAK Technology, Inc.	A	2306	F	Broadcom Corporation	Stream TV
10:2C:6B:99:75:63	AMPAK Technology, Inc.	A	6B06	F	Broadcom Corporation	Living Room
14:7D:DA:0F:66:E8	Apple, Inc.	9	4406	F	Broadcom Corporation	mbp
C0:97:27:1C:2C:6B	SAMSUNG ELECTRO-MECHANICS(THAILAND)	7	2304	F	Broadcom Corporation	[TV] Samsung 8 Series (65)
F8:04:2E:81:2F:33	SAMSUNG ELECTRO-MECHANICS(THAILAND)	7	2304	F	Broadcom Corporation	[TV] UN55JU650D
84:A4:66:BA:96:6D	Samsung Electronics Co.,Ltd	6	410E	F	Broadcom Corporation	[TV]Samsung LED55
6C:56:97:31:8E:DA	Amazon Technologies Inc.	8	2304	131	Cypress Semiconductor	Echo Show-2N2
2C:33:61:E6:E2:07	Apple, Inc.	B	240C	131	Cypress Semiconductor	apple's Keyboard
2C:33:61:E6:E2:07	Apple, Inc.	B	240C	131	Cypress Semiconductor	ukeybd_KPAL
FE:86:B6:4F:FC:0D	UNKNOWN_COMP_BY_BDADDR	8	3120	1D6	G-wearables inc.	BT201-AUDIO
AC:67:5D:A:0A:8E	Intel Corporate	9	100	2	Intel Corp.	EXPCQ6092
C8:B2:9F:02:25:83	Intel Corporate	B	216E	2	Intel Corp.	DESKTOP-EC66KUJ
00:42:00:00:00:8E	Intel Corporate	B	2237	2	Intel Corp.	CVLAPTOP07
34:00:00:00:00:02	Intel Corporate	B	226A	2	Intel Corp.	FCS00200079
AC:00:00:00:00:00:00	TAIYO YUDEN CO.,LTD	5	4633	48	Marvell Technology Group Ltd.	TJQLJ175205968
00:00:00:00:00:00	Garmin International	7	0	46	MediaTek, Inc.	BT_Garmin DriveSmart #3972245662
E8:9E:00:00:00:70	Shen Hai Precision Ind. Co.,Ltd.	6	928	46	MediaTek, Inc.	XBR-75X850E
E8:51:00:00:00:6B9	Qingdao Intelligent&Precise Electronics Co.,Ltd.	A	12E4	46	MediaTek, Inc.	SmartTV 4K
70:09:71:69:80:D1	Samsung Electronics Co.,Ltd	9	1005	46	MediaTek, Inc.	[TV] Samsung TU700D 50 TV
70:09:71:69:80:D1	Samsung Electronics Co.,Ltd	9	1005	46	MediaTek, Inc.	[TV] Samsung TU7000 50 TV
C0:23:6E:00:00:00	Samsung Electronics Co.,Ltd	9	1005	46	MediaTek, Inc.	[TV] Samsung Q60AA 65 TV
BC:7E:00:00:00:00	Samsung Electronics Co.,Ltd	9	1228	46	MediaTek, Inc.	[TV] Samsung 7 Series (55)
00:7C:00:00:00:00	Samsung Electronics Co.,Ltd	9	308	46	MediaTek, Inc.	[TV] Samsung 7 Series (55)
D0:03:00:00:00:00	Samsung Electronics Co.,Ltd	9	308	46	MediaTek, Inc.	[TV] Samsung 7 Series (43)
D4:9D:00:00:00:00	Samsung Electronics Co.,Ltd	9	317	46	MediaTek, Inc.	[TV] Samsung 7 Series (50)
70:09:71:69:80:D1	Samsung Electronics Co.,Ltd	9	7003	46	MediaTek, Inc.	[TV] Samsung TU7000 50 TV
70:09:71:69:80:D1	Samsung Electronics Co.,Ltd	9	7005	46	MediaTek, Inc.	[TV] Samsung TU700D 50 TV
4C:C9:00:00:00:00	Samsung Electronics Co.,Ltd	9	803	46	MediaTek, Inc.	[TV] Samsung 7 Series (43)
AC:67:5D:A:0A:8E	Intel Corporate	9	100	1	Nokia Mobile Phones	EXPCQ6092
4C:CE:00:00:00:00	Danlaw Inc	7	25A	1D	Qualcomm	DL-2233301744
0C:02:00:00:00:00	Samsung Electronics Co.,Ltd	9	2BE	1D	Qualcomm	NULL
5C:C1:00:00:00:00	Samsung Electronics Co.,Ltd	8	321	1D	Qualcomm	[TV] Samsung 6 Series (43)
5C:C1:00:00:00:00	Samsung Electronics Co.,Ltd	8	321	1D	Qualcomm	[TV] Samsung 6 Series (43)
7C:64:00:00:00:00	Samsung Electronics Co.,Ltd	8	321	1D	Qualcomm	[TV] Samsung 6 Series (43)
7C:64:00:00:00:00	Samsung Electronics Co.,Ltd	8	321	1D	Qualcomm	[TV] Samsung 6 Series (43)
D0:03:00:00:00:00	Samsung Electronics Co.,Ltd	8	321	1D	Qualcomm	[Refrigerator] Samsung
00:06:00:00:00:00	Roving Networks	5	1A31	A	Qualcomm Technologies International, Ltd. (QTI)	PLREP-E41D
88:E0:00:00:00:00	Shinwa industries(China) ltd.	8	2918	A	Qualcomm Technologies International, Ltd. (QTI)	NULL
80:5E:00:00:00:00	YEALINK(XIAMEN) NETWORK TECHNOLOGY CO.,LTD.	8	2918	A	Qualcomm Technologies International, Ltd. (QTI)	Yealink MP50
5C:00:00:00:00:00	Sichuan AI-Link Technology Co., Ltd.	7	7E1C	5D	Realtek Semiconductor Corporation	rk3328
DC:00:00:00:00:00	UNKNOWN_COMP_BY_BDADDR	7	6AE6	5D	Realtek Semiconductor Corporation	BOOMBOX
DC:00:00:00:00:00	Shenzhen Feasycom Technology Co., Ltd.	9	6	A2D	Shenzhen Feasycom Technology Co., Ltd.	979869022455
14:7D:DA:0F:66:E8	Garmin International	6	1B5D	D	Texas Instruments Inc.	BT_nuvi #3912042869
7C:64:00:00:00:00	Samsung Electronics Co.,Ltd	8	6321	801D	UNKNOWN_COMP_BY_BT_CID	[TV] Samsung 6 Series (43)
BD:94:2C:00:00:00	UNKNOWN_COMP_BY_BDADDR	9	3520	39D6	UNKNOWN_COMP_BY_BT_CID	CAD-4057
B7:89:B9:00:00:00	UNKNOWN_COMP_BY_BDADDR	9	3120	5D6	Zhuhai Jieli technology Co.,Ltd	CAD-6057
FE:86:B6:4F:FC:0D	UNKNOWN_COMP_BY_BDADDR	3	3120	5D6	Zhuhai Jieli technology Co.,Ltd	BT201-AUDIO
FE:86:B6:4F:FC:0D	UNKNOWN_COMP_BY_BDADDR	8	3120	5D6	Zhuhai Jieli technology Co.,Ltd	BT201-AUDIO

Same BDADR

# Example Data

device_bdaddr	comp_by_bdaddr	VersNr	SubVersNr	CompId	comp_by_CompId	device_name
FE:86:B6:4F:FC:0D	UNKNOWN_COMP_BY_BDADDR	8	3120	5D0	Anova Applied Electronics	BT201-AUDIO
70:09:71:69:80:D1	Samsung Electronics Co.,Ltd	9	1005	47	Bluegiga	[TV] Samsung TU7000 50 TV
10:2C:6B:91:A8:F5	AMPAK Technology, Inc.	A	2306	F	Broadcom Corporation	Stream TV
10:2C:6B:99:75:63	AMPAK Technology, Inc.	A	6B06	F	Broadcom Corporation	Living Room
14:7D:DA:0F:66:E8	Apple, Inc.	9	4406	F	Broadcom Corporation	mbp
C0:97:27:1C:2C:6B	SAMSUNG ELECTRO-MECHANICS(THAILAND)	7	2304	F	Broadcom Corporation	[TV] Samsung 8 Series (65)
F8:04:2E:81:2F:33	SAMSUNG ELECTRO-MECHANICS(THAILAND)	7	2304	F	Broadcom Corporation	[TV] UN55JU650D
84:A4:66:BA:96:6D	Samsung Electronics Co.,Ltd	6	410E	F	Broadcom Corporation	[TV]Samsung LED55
6C:56:97:31:8E:DA	Amazon Technologies Inc.	8	2304	131	Cypress Semiconductor	Echo Show-2N2
2C:33:61:E6:E2:07	Apple, Inc.	B	240C	131	Cypress Semiconductor	apple's Keyboard
2C:33:61:E6:E2:07	Apple, Inc.	B	240C	131	Cypress Semiconductor	ukeybd_KPAL
FE:86:B6:4F:FC:0D	UNKNOWN_COMP_BY_BDADDR	8	3120	1D6	G-wearables inc.	BT201-AUDIO
AC:67:5D:A:0A:8E	Intel Corporate	9	100	2	Intel Corp.	EXPCQ6092
C8:B2:9F:0:25:83	Intel Corporate	B	216E	2	Intel Corp.	DESKTOP-EC66KUJ
00:42:0:0:0:8E	Intel Corporate	B	2237	2	Intel Corp.	CVLAPTOP07
34:0:0:0:0:02	Intel Corporate	B	226A	2	Intel Corp.	FCS00200079
AC:0:0:0:0:00	TAIYO YUDEN CO.,LTD	5	4633	48	Marvell Technology Group Ltd.	TJQLJ175205968
00:00:00:00:00:00	Garmin International	7	0	46	MediaTek, Inc.	BT_Garmin DriveSmart #3972245662
E8:9E:0:0:0:70	non Hai Precision Ind. Co.,Ltd.	6	928	46	MediaTek, Inc.	XBR-75X850E
E8:51:0:0:0:6B9	Qingdao Intelligent&Precise Electronics Co.,Ltd.	A	12E4	46	MediaTek, Inc.	SmartTV 4K
70:09:0:0:0:1:95	Samsung Electronics Co.,Ltd	9	1005	46	MediaTek, Inc.	[TV] Samsung TU700D 50 TV
70:09:0:0:0:0:D1	Samsung Electronics Co.,Ltd	9	1005	46	MediaTek, Inc.	[TV] Samsung TU7000 50 TV
C0:23:0:0:0:2:EF	Samsung Electronics Co.,Ltd	9	1005	46	MediaTek, Inc.	[TV] Samsung Q60AA 65 TV
BC:7E:0:0:0:3:0D	Samsung Electronics Co.,Ltd	9	1228	46	MediaTek, Inc.	[TV] Samsung 7 Series (55)
00:7C:0:0:0:2:86	Samsung Electronics Co.,Ltd	9	308	46	MediaTek, Inc.	[TV] Samsung 7 Series (55)
D0:03:0:0:0:0:EF	Samsung Electronics Co.,Ltd	9	308	46	MediaTek, Inc.	[TV] Samsung 7 Series (43)
D4:9D:0:0:0:0:EF	Samsung Electronics Co.,Ltd	9	317	46	MediaTek, Inc.	[TV] Samsung 7 Series (50)
70:09:0:0:0:0:D1	Samsung Electronics Co.,Ltd	9	7003	46	MediaTek, Inc.	[TV] Samsung TU7000 50 TV
70:09:0:0:0:1:95	Samsung Electronics Co.,Ltd	9	7005	46	MediaTek, Inc.	[TV] Samsung TU700D 50 TV
4C:C9:0:0:0:E:93	Samsung Electronics Co.,Ltd	9	803	46	MediaTek, Inc.	[TV] Samsung 7 Series (43)
AC:67:0:0:0:A:8E	Intel Corporate	9	100	1	Nokia Mobile Phones	EXPCQ6092
4C:CE:0:0:0:7:BB	Danlaw Inc	7	25A	1D	Qualcomm	DL-2233301744
0C:02:0:0:0:5:67	Samsung Electronics Co.,Ltd	9	2BE	1D	Qualcomm	NULL
5C:C1:0:0:0:7:1B	Samsung Electronics Co.,Ltd	8	321	1D	Qualcomm	[TV] Samsung 6 Series (43)
5C:C1:0:0:0:A:01	Samsung Electronics Co.,Ltd	8	321	1D	Qualcomm	[TV] Samsung 6 Series (43)
7C:64:0:0:0:4:6F	Samsung Electronics Co.,Ltd	8	321	1D	Qualcomm	[TV] Samsung 6 Series (43)
7C:64:0:0:0:4:75	Samsung Electronics Co.,Ltd	8	321	1D	Qualcomm	[TV] Samsung 6 Series (43)
D0:03:0:0:0:A:CB	Samsung Electronics Co.,Ltd	8	321	1D	Qualcomm	[Refrigerator] Samsung
00:06:0:0:0:4:1D	Roving Networks	5	1A31	A	Qualcomm Technologies International, Ltd. (QTI)	PLREP-E41D
88:E0:0:0:0:F:FA	Shinwa industries(China) ltd.	8	2918	A	Qualcomm Technologies International, Ltd. (QTI)	NULL
80:5E:0:0:0:C:F8	YEALINK(XIAMEN) NETWORK TECHNOLOGY CO.,LTD.	8	2918	A	Qualcomm Technologies International, Ltd. (QTI)	Yealink MP50
5C:0C:0:0:0:0:A2	Sichuan AI-Link Technology Co., Ltd.	7	7E1C	5D	Realtek Semiconductor Corporation	rk3328
DC:0:0:0:0:0:0	UNKNOWN_COMP_BY_BDADDR	7	6AE6	5D	Realtek Semiconductor Corporation	BOOMBOX
DC:0:0:0:0:0:0	Shenzhen Feasycom Technology Co., Ltd.	9	6	A2D	Shenzhen Feasycom Technology Co., Ltd.	979869022455
14:8:0:0:0:0:18	Garmin International	6	1B5D	D	Texas Instruments Inc.	BT_nuvi #3912042869
7C:64:0:0:0:4:6F	Samsung Electronics Co.,Ltd	8	6321	801D	UNKNOWN_COMP_BY_BT_CID	[TV] Samsung 6 Series (43)
BD:94:2C:0:0:0:2D:74	UNKNOWN_COMP_BY_BDADDR	9	3520	39D6	UNKNOWN_COMP_BY_BT_CID	CAD-4057
B7:89:B9:0:0:0:05:00	UNKNOWN_COMP_BY_BDADDR	9	3120	5D6	Zhuhai Jieli technology Co.,Ltd	CAD-6057
FE:86:B6:4F:FC:0D	UNKNOWN_COMP_BY_BDADDR	3	3120	5D6	Zhuhai Jieli technology Co.,Ltd	BT201-AUDIO
FE:86:B6:4F:FC:0D	UNKNOWN_COMP_BY_BDADDR	8	3120	5D6	Zhuhai Jieli technology Co.,Ltd	BT201-AUDIO

Same BDADR

3 bitflips?

# Example Data

device_baddr	comp_by_baddr	VersNr	SubVersNr	CompId	comp_by_CompId	device_name
FE:86:B6:4F:FC:0D	UNKNOWN_COMP_BY_BDADDR	8	3120	5D0	Anova Applied Electronics	BT201-AUDIO
70:09:71:69:80:D1	Samsung Electronics Co.,Ltd	9	1005	47	Bluegiga	[TV] Samsung TU7000 50 TV
10:2C:6B:91:A8:F5	AMPAK Technology, Inc.	A	2306	F	Broadcom Corporation	Stream TV
10:2C:6B:99:75:63	AMPAK Technology, Inc.	A	6B06	F	Broadcom Corporation	Living Room
14:7D:DA:0F:66:E8	Apple, Inc.	9	4406	F	Broadcom Corporation	mbp
C0:97:27:1C:2C:6B	SAMSUNG ELECTRO-MECHANICS(THAILAND)	7	2304	F	Broadcom Corporation	[TV] Samsung 8 Series (65)
F8:04:2E:81:2F:33	SAMSUNG ELECTRO-MECHANICS(THAILAND)	7	2304	F	Broadcom Corporation	[TV] UN55JU650D
84:A4:66:BA:96:6D	Samsung Electronics Co.,Ltd	6	410E	F	Broadcom Corporation	[TV]Samsung LED55
6C:56:97:31:8E:DA	Amazon Technologies Inc.	8	2304	131	Cypress Semiconductor	Echo Show-2N2
2C:33:61:E6:E2:07	Apple, Inc.	B	240C	131	Cypress Semiconductor	apple's Keyboard
2C:33:61:E6:E2:07	Apple, Inc.	B	240C	131	Cypress Semiconductor	ukeybd_KPAL
FE:86:B6:4F:FC:0D	UNKNOWN_COMP_BY_BDADDR	8	3120	1D6	G-wearables inc.	BT201-AUDIO
AC:67:5D:A:0A:8E	Intel Corporate	9	100		Intel Corp.	EXPCQ6092
C8:B2:9F:25:83	Intel Corporate	B	216E		Intel Corp.	DESKTOP-EC66KUJ
00:42:00:00:8E	Intel Corporate	B	2237		Intel Corp.	CVLAPTOP07
34:00:00:00:02	Intel Corporate	B	226A		Intel Corp.	FCS00200079
AC:00:00:00:00:00	TAIYO YUDEN CO.,LTD	5	4633		Marvell Technology Group Ltd.	TJQLJ175205968
00:00:00:00:00:00	Garmin International	7	0		MediaTek, Inc.	BT_Garmin DriveSmart #3972245662
00:00:00:00:00:00	Shen Hai Precision Ind. Co.,Ltd.	6	928		MediaTek, Inc.	XBR-75X850E
E8:51:00:00:00:00	Qingdao Intelligent&Precise Electronics Co.,Ltd.	A	12F		MediaTek, Inc.	SmartTV 4K
70:09:00:00:00:00	Samsung Electronics Co.,Ltd	9	1005		MediaTek, Inc.	[TV] Samsung TU700D 50 TV
70:09:00:00:00:00	Samsung Electronics Co.,Ltd	9	1005		MediaTek, Inc.	[TV] Samsung TU7000 50 TV
C0:23:00:00:00:00	Samsung Electronics Co.,Ltd	9	1005		MediaTek, Inc.	[TV] Samsung Q60AA 65 TV
BC:7E:00:00:00:00	Samsung Electronics Co.,Ltd	9	1228		MediaTek, Inc.	[TV] Samsung 7 Series (55)
00:7C:00:00:00:00	Samsung Electronics Co.,Ltd	9	308		MediaTek, Inc.	[TV] Samsung 7 Series (55)
D0:03:00:00:00:00	Samsung Electronics Co.,Ltd	9	308		MediaTek, Inc.	[TV] Samsung 7 Series (43)
D4:9D:00:00:00:00	Samsung Electronics Co.,Ltd	9	317		MediaTek, Inc.	[TV] Samsung 7 Series (50)
70:09:00:00:00:00	Samsung Electronics Co.,Ltd	9	7003		MediaTek, Inc.	[TV] Samsung TU7000 50 TV
70:09:00:00:00:00	Samsung Electronics Co.,Ltd	9	7005		MediaTek, Inc.	[TV] Samsung TU700D 50 TV
4C:C9:00:00:00:00	Samsung Electronics Co.,Ltd	9	803		MediaTek, Inc.	[TV] Samsung 7 Series (43)
AC:67:00:00:00:00	Intel Corporate	9	100		Nokia Mobile Phones	EXPCQ6092
4C:CE:00:00:00:00	Danlaw Inc	7	25A		Qualcomm	DL-2233301744
0C:02:00:00:00:00	Samsung Electronics Co.,Ltd	9	2BE		Qualcomm	NULL
5C:C1:00:00:00:00	Samsung Electronics Co.,Ltd	8	321		Qualcomm	[TV] Samsung 6 Series (43)
5C:C1:00:00:00:00	Samsung Electronics Co.,Ltd	8	321		Qualcomm	[TV] Samsung 6 Series (43)
7C:64:00:00:00:00	Samsung Electronics Co.,Ltd	8	321		Qualcomm	[TV] Samsung 6 Series (43)
7C:64:00:00:00:00	Samsung Electronics Co.,Ltd	8	321		Qualcomm	[TV] Samsung 6 Series (43)
D0:03:00:00:00:00	Samsung Electronics Co.,Ltd	8			Qualcomm	[Refrigerator] Samsung
00:06:00:00:00:00	Roving Networks	5			Qualcomm Technologies International, Ltd. (QTI)	PLREP-E41D
88:E0:00:00:00:00	Shinwa industries(China) ltd.	8	291		Qualcomm Technologies International, Ltd. (QTI)	NULL
80:5E:00:00:00:00	YEALINK(XIAMEN) NETWORK TECHNOLOGY CO.,LTD.	8	291		Qualcomm Technologies International, Ltd. (QTI)	Yealink MP50
5C:00:00:00:00:00	Sichuan AI-Link Technology Co., Ltd.	7	7E1C		Realtek Semiconductor Corporation	rk3328
DC:00:00:00:00:00	UNKNOWN_COMP_BY_BDADDR	7	6AE6		Realtek Semiconductor Corporation	BOOMBOX
DC:00:00:00:00:00	Shenzhen Feasycom Technology Co., Ltd.	9	6		Shenzhen Feasycom Technology Co., Ltd.	979869022455
14:80:00:00:00:00	Garmin International	6	1B5D		Texas Instruments Inc.	BT_nuvi #3912042869
7C:64:00:00:00:00	Samsung Electronics Co.,Ltd	8	6321		UNKNOWN_COMP_BY_BT_CID	[TV] Samsung 6 Series (43)
BD:94:2C:00:00:00	UNKNOWN_COMP_BY_BDADDR	9	3520	5D6	UNKNOWN_COMP_BY_BT_CID	CAD-4057
B7:89:B9:00:00:00	UNKNOWN_COMP_BY_BDADDR	9	3120	5D6	Zhuhai Jieli technology Co.,Ltd	CAD-6057
FE:86:B6:4F:FC:0D	UNKNOWN_COMP_BY_BDADDR	3	3120	5D6	Zhuhai Jieli technology Co.,Ltd	BT201-AUDIO
FE:86:B6:4F:FC:0D	UNKNOWN_COMP_BY_BDADDR	8	3120	5D6	Zhuhai Jieli technology Co.,Ltd	BT201-AUDIO

Same BDADR

1 bit flip  
(0b0101 -> 0b0001)

3 bitflips?

# Example Data



device_baddr	comp_by_baddr	VersNr	SubVersNr	CompId	comp_by_CompId	device_name
FE:86:B6:4F:FC:0D	UNKNOWN_COMP_BY_BDADDR	8	3120	5D0	Anova Applied Electronics	BT201-AUDIO
70:09:71:69:80:D1	Samsung Electronics Co.,Ltd	9	1005	47	Bluegiga	[TV] Samsung TU7000 50 TV
10:2C:6B:91:A8:F5	AMPAK Technology, Inc.	A	2306	F	Broadcom Corporation	Stream TV
10:2C:6B:99:75:63	AMPAK Technology, Inc.	A	6B06	F	Broadcom Corporation	Living Room
14:7D:DA:0F:66:E8	Apple, Inc.	9	4406	F	Broadcom Corporation	mbp
C0:97:27:1C:2C:6B	SAMSUNG ELECTRO-MECHANICS(THAILAND)	7	2304	F	Broadcom Corporation	[TV] Samsung 8 Series (65)
F8:04:2E:81:2F:33	SAMSUNG ELECTRO-MECHANICS(THAILAND)	7	2304	F	Broadcom Corporation	[TV] UN55JU650D
84:A4:66:BA:96:6D	Samsung Electronics Co.,Ltd	6	410E	F	Broadcom Corporation	[TV]Samsung LED55
6C:56:97:31:8E:DA	Amazon Technologies Inc.	8	2304	131	Cypress Semiconductor	Echo Show-2N2
2C:33:61:E6:E2:07	Apple, Inc.	B	240C	131	Cypress Semiconductor	apple's Keyboard
2C:33:61:E6:E2:07	Apple, Inc.	B	240C	131	Cypress Semiconductor	ukeybd_KPAL
FE:86:B6:4F:FC:0D	UNKNOWN_COMP_BY_BDADDR	8	3120	1D6	G-wearables inc.	BT201-AUDIO
AC:67:5D:A:0A:8E	Intel Corporate		100		Intel Corp.	EXPCQ6092
C8:B2:9F:25:83	Intel Corporate		216E		Intel Corp.	DESKTOP-EC66KUJ
00:42:00:00:8E	Intel Corporate		2237		Intel Corp.	CVLAPTOP07
34:00:00:00:02	Intel Corporate		226A		Intel Corp.	FCS00200079
AC:00:00:00:00:00	TAIYO YUDEN CO.,LTD		4633		Marvell Technology Group Ltd.	TJQLJ175205968
00:00:00:00:00:00	Garmin International		0		MediaTek, Inc.	BT_Garmin DriveSmart #3972245662
E8:9E:00:00:00:00	non Hai Precision Ind. Co.,Ltd.		928		MediaTek, Inc.	XBR-75X850E
E8:51:00:00:00:00	Qingdao Intelligent&Precise Electronics Co		02F		MediaTek, Inc.	SmartTV 4K
70:09:00:00:00:00	Samsung Electronics Co.,Ltd				MediaTek, Inc.	[TV] Samsung TU700D 50 TV
70:09:00:00:00:00	Samsung Electronics Co.,Ltd				MediaTek, Inc.	[TV] Samsung TU7000 50 TV
C0:23:00:00:00:00	Samsung Electronics Co.,Ltd				MediaTek, Inc.	[TV] Samsung Q60AA 65 TV
BC:7E:00:00:00:00	Samsung Electronics Co.,Ltd		1228		MediaTek, Inc.	[TV] Samsung 7 Series (55)
00:7C:00:00:00:00	Samsung Electronics Co.,Ltd		308		MediaTek, Inc.	[TV] Samsung 7 Series (55)
D0:03:00:00:00:00	Samsung Electronics Co.,Ltd		308		MediaTek, Inc.	[TV] Samsung 7 Series (43)
D4:9D:00:00:00:00	Samsung Electronics Co.,Ltd		317		MediaTek, Inc.	[TV] Samsung 7 Series (50)
70:09:00:00:00:00	Samsung Electronics Co.,Ltd		7003		MediaTek, Inc.	[TV] Samsung TU7000 50 TV
70:09:00:00:00:00	Samsung Electronics Co.,Ltd		7005		MediaTek, Inc.	[TV] Samsung TU700D 50 TV
4C:C9:00:00:00:00	Samsung Electronics Co.,Ltd		803		MediaTek, Inc.	[TV] Samsung 7 Series (43)
AC:67:00:00:00:00	Intel Corporate		100		Nokia Mobile Phones	EXPCQ6092
4C:CE:00:00:00:00	Danlaw Inc		25A		Qualcomm	DL-2233301744
0C:02:00:00:00:00	Samsung Electronics Co.,Ltd		2BE		Qualcomm	NULL
5C:C1:00:00:00:00	Samsung Electronics Co.,Ltd		321		Qualcomm	[TV] Samsung 6 Series (43)
5C:C1:00:00:00:00	Samsung Electronics Co.,Ltd		321		Qualcomm	[TV] Samsung 6 Series (43)
7C:64:00:00:00:00	Samsung Electronics Co.,Ltd		321		Qualcomm	[TV] Samsung 6 Series (43)
7C:64:00:00:00:00	Samsung Electronics Co.,Ltd		321		Qualcomm	[TV] Samsung 6 Series (43)
D0:03:00:00:00:00	Samsung Electronics Co.,Ltd				Qualcomm	[Refrigerator] Samsung
00:06:00:00:00:00	Roving Networks				Qualcomm Technologies International, Ltd. (QTI)	PLREP-E41D
88:E0:00:00:00:00	Shinwa industries(China) ltd.				Qualcomm Technologies International, Ltd. (QTI)	NULL
80:5E:00:00:00:00	YEALINK(XIAMEN) NETWORK TECHNOLOGY CO.,LTD		91		Qualcomm Technologies International, Ltd. (QTI)	Yealink MP50
5C:00:00:00:00:00	Sichuan AI-Link Technology Co., Ltd.		7E1C		Realtek Semiconductor Corporation	rk3328
DC:00:00:00:00:00	UNKNOWN_COMP_BY_BDADDR		6AE6		Realtek Semiconductor Corporation	BOOMBOX
14:80:00:00:00:00	Shenzhen Feasycom Technology Co., Ltd.		6		Shenzhen Feasycom Technology Co., Ltd.	979869022455
14:80:00:00:00:00	Garmin International		1B5D		Texas Instruments Inc.	BT_nuvi #3912042869
7C:64:00:00:00:00	Samsung Electronics Co.,Ltd		6321		UNKNOWN_COMP_BY_BT_CID	[TV] Samsung 6 Series (43)
BD:94:2C:00:00:00	UNKNOWN_COMP_BY_BDADDR		3520	5D6	UNKNOWN_COMP_BY_BT_CID	CAD-4057
B7:89:B9:00:00:00	UNKNOWN_COMP_BY_BDADDR		3120	5D6	Zhuhai Jieli technology Co.,Ltd	CAD-6057
FE:86:B6:4F:FC:0D	UNKNOWN_COMP_BY_BDADDR	3	3120	5D6	Zhuhai Jieli technology Co.,Ltd	BT201-AUDIO
FE:86:B6:4F:FC:0D	UNKNOWN_COMP_BY_BDADDR	8	3120	5D6	Zhuhai Jieli technology Co.,Ltd	BT201-AUDIO

Same BDADR

3 bit flips?  
(0b1000 -> 0b0011)

1 bit flip  
(0b0101 -> 0b0001)

3 bitflips?

# Example Data

device_bdaddr	comp_by_bdaddr	rand?	VersNr	SubVersNr	CompId	comp_by_CompId	device_name
62:B6:3C:CC:51:EB	NON-PUBLIC_BDADDR	1	9	5400	4C	Apple, Inc.	NULL
79:19:DC:60:75:98	NON-PUBLIC_BDADDR	1	C	6310	4C	Apple, Inc.	NULL
7D:17:D8:82:A7:C4	NON-PUBLIC_BDADDR	1	C	6310	4C	Apple, Inc.	NULL
76:D8:8E:51:63:65	NON-PUBLIC_BDADDR	1	C	6520	4C	Apple, Inc.	NULL
56:02:07:04:75:03	NON-PUBLIC_BDADDR	1	C	6520	4C	Apple, Inc.	NULL
78:74:1A:DC:CE:F0	NON-PUBLIC_BDADDR	1	C	6520	4C	Apple, Inc.	NULL
E9:D2:84:15:36:62	NON-PUBLIC_BDADDR	1	9	7301	4C	Apple, Inc.	NULL
E0:A1:6B:4B:87:01	NON-PUBLIC_BDADDR	1	9	7301	4C	Apple, Inc.	NULL
F6:83:8F:86:D8:63	NON-PUBLIC_BDADDR	1	9	7301	4C	Apple, Inc.	NULL
D8:18:50:32:F3:1F	NON-PUBLIC_BDADDR	1	9	7301	4C	Apple, Inc.	NULL
18:B4:30:59:67:77	NON-PUBLIC_BDADDR	1	6	1	45	Atheros Communications, Inc.	Nest Cam
52:9B:B4:1D:65:0D	NON-PUBLIC_BDADDR	1	B	42C	2B0	Bestechnic(Shanghai),Ltd	JBL TUNE230NC TWS-LE
6C:4A:85:2C:C3:A9	Apple, Inc.	0	9	420E	F	Broadcom Corporation	NULL
50:32:37:9C:2D:30	Apple, Inc.	0	8	6607	F	Broadcom Corporation	NULL
A8:51:AB:D1:F3:C3	Apple, Inc.	0	C	6E	F	Broadcom Corporation	NULL
2C:4C:C6:1C:91:83	Murata Manufacturing Co., Ltd.	0	7	2209	F	Broadcom Corporation	Venus_2C4CC61C9183
FC:F1:36:D1:3A:FA	Samsung Electronics Co.,Ltd	0	6	410E	F	Broadcom Corporation	[TV] Family Room
FC:F1:36:D1:3A:FA	Samsung Electronics Co.,Ltd	0	6	410E	F	Broadcom Corporation	[TV] Living room
F3:33:92:FB:15:69	NON-PUBLIC_BDADDR	1	8	1200	131	Cypress Semiconductor	906764167ECA33A8E9
BE:E9:2F:71:FA:1A	UNKNOWN_COMP_BY_BDADDR	0	8	1CB1	48	Marvell Technology Group Ltd.	NULL
66:6C:80:66:AF:FE	UNKNOWN_COMP_BY_BDADDR	0	8	1CB1	48	Marvell Technology Group Ltd.	NULL
E0:99:45:3F:1E:71	NON-PUBLIC_BDADDR	1	9	A2	59	Nordic Semiconductor ASA	SPD-BLE0668517
FA:71:89:EF:E6:93	NON-PUBLIC_BDADDR	1	9	A7	59	Nordic Semiconductor ASA	rnet
F5:57:2E:48:96:05	NON-PUBLIC_BDADDR	1	9	B6	59	Nordic Semiconductor ASA	FCAB620360822
E4:D4:97:9B:B6:13	NON-PUBLIC_BDADDR	1	9	B7	59	Nordic Semiconductor ASA	IoT9BB613
C5:09:25:D3:5F:29	NON-PUBLIC_BDADDR	1	9	B7	59	Nordic Semiconductor ASA	IoTVD35F29
C3:3C:6E:74:F7:35	NON-PUBLIC_BDADDR	1	9	B7	59	Nordic Semiconductor ASA	IoT74F735
DF:17:12:E6:7D:A0	NON-PUBLIC_BDADDR	1	9	B7	59	Nordic Semiconductor ASA	IoTVE67DA0
EC:4E:72:76:51:FA	NON-PUBLIC_BDADDR	1	9	B7	59	Nordic Semiconductor ASA	IoT7651FA
F8:6D:F0:81:BA:3C	NON-PUBLIC_BDADDR	1	9	B7	59	Nordic Semiconductor ASA	IoT81BA3C
F4:07:9E:2F:54:C2	NON-PUBLIC_BDADDR	1	A	CC	59	Nordic Semiconductor ASA	NULL
E6:AE:02:49:2A:F4	NON-PUBLIC_BDADDR	1	A	CC	59	Nordic Semiconductor ASA	NULL
6A:58:78:34:90:7F	NON-PUBLIC_BDADDR	1	B	5554	1D	Qualcomm	NULL
EC:81:93:F1:35:AD	Logitech, Inc	0	9	3716	A	Qualcomm Technologies International, Ltd. (QTIL)	NULL
66:1B:11:54:B3:19	NON-PUBLIC_BDADDR	1	6	1D87	A	Qualcomm Technologies International, Ltd. (QTIL)	FIXD
B8:3A:9D:8A:3B:D9	Alarm.com	0	7	D8E1	5D	Realtek Semiconductor Corporation	ALAM (8A:3B:D8)
34:13:43:07:DB:DE	GE Lighting	0	8	E051	5D	Realtek Semiconductor Corporation	AEA76C97625A
78:9C:E7:02:4C:0B	Shenzhen Aikede Technology Co., Ltd	0	8	22BB	211	Telink Semiconductor Co. Ltd	BLE003U
A4:C1:38:73:2E:8B	Telink Semiconductor (Taipei) Co. Ltd.	0	8	22BB	211	Telink Semiconductor Co. Ltd	ihoment_H6110_2E8B
A4:C1:38:38:72:1C	Telink Semiconductor (Taipei) Co. Ltd.	0	8	22BB	211	Telink Semiconductor Co. Ltd	ihoment_H6110_721C
CC:04:B4:0B:C5:21	Select Comfort	0	6	120	D	Texas Instruments Inc.	cc:04:b4:0b:c5:21
B4:60:77:79:D3:CD	Sichuan Changhong Electric Ltd.	0	8	321	D	Texas Instruments Inc.	Sbecb43f15400aaf6C
60:98:66:44:E4:64	Texas Instruments	0	A	213	D	Texas Instruments Inc.	S6c0a7c71fda94e9bC
98:04:ED:C5:CD:68	UNKNOWN_COMP_BY_BDADDR	0	8	321	D	Texas Instruments Inc.	Se019c1365abce9b9C
A0:98:66:0D:EC:BE	UNKNOWN_COMP_BY_BDADDR	0	8	321	D	Texas Instruments Inc.	Se41358d612e55e20C

# Example Data

device_bdaddr	comp_by_bdaddr	rand?	VersNr	SubVersNr	CompId	comp_by_CompId	device_name
62:B6:3C:CC:51:EB	NON-PUBLIC_BDADDR	1	9	5400	4C	Apple, Inc.	NULL
79:19:DC:60:75:98	NON-PUBLIC_BDADDR	1	C	6310	4C	Apple, Inc.	NULL
7D:17:D8:82:A7:C4	NON-PUBLIC_BDADDR	1	C	6310	4C	Apple, Inc.	NULL
76:D8:8E:51:63:65	NON-PUBLIC_BDADDR	1	C	6520	4C	Apple, Inc.	NULL
56:02:07:04:75:03	NON-PUBLIC_BDADDR	1	C	6520	4C	Apple, Inc.	NULL
78:74:1A:DC:CE:F0	NON-PUBLIC_BDADDR	1	C	6520	4C	Apple, Inc.	NULL
E9:D2:84:15:36:62	NON-PUBLIC_BDADDR	1	9	7301	4C	Apple, Inc.	NULL
E0:A1:6B:4B:87:01	NON-PUBLIC_BDADDR	1	9	7301	4C	Apple, Inc.	NULL
F6:83:8F:86:D8:63	NON-PUBLIC_BDADDR	1	9	7301	4C	Apple, Inc.	NULL
D8:18:50:32:F3:1F	NON-PUBLIC_BDADDR	1	9	7301	4C	Apple, Inc.	NULL
18:B4:30:59:67:77	NON-PUBLIC_BDADDR	1	6	1	45	Atheros Communications, Inc.	Nest Cam
52:9B:B4:1D:65:0D	NON-PUBLIC_BDADDR	1	B	42C	2B0	Bestechnic(Shanghai),Ltd	JBL TUNE230NC TWS-LE
6C:4A:85:2C:C3:A9	Apple, Inc.	0	9	420E	F	Broadcom Corporation	NULL
50:32:37:9C:2D:30	Apple, Inc.	0	8	6607	F	Broadcom Corporation	NULL
A8:51:AB:D1:F3:C3	Apple, Inc.	0	C	6E	F	Broadcom Corporation	NULL
2C:4C:C6:1C:91:83	Murata Manufacturing Co., Ltd.	0	7	2209	F	Broadcom Corporation	Venus_2C4CC61C9183
FC:F1:36:D1:3A:FA	Samsung Electronics Co.,Ltd	0	6	410E	F	Broadcom Corporation	[TV] Family Room
FC:F1:36:D1:3A:FA	Samsung Electronics Co.,Ltd	0	6	410E	F	Broadcom Corporation	[TV] Living room
F3:33:92:FB:15:69	NON-PUBLIC_BDADDR	1	8	1200	131	Cypress Semiconductor	906764167ECA33A8E9
BE:E9:2F:71:FA:1A	UNKNOWN_COMP_BY_BDADDR	0	8	1CB1	48	Marvell Technology Group Ltd.	NULL
66:6C:80:66:AF:FE	UNKNOWN_COMP_BY_BDADDR	0	8	1CB1	48	Marvell Technology Group Ltd.	NULL
E0:99:45:3F:1E:71	NON-PUBLIC_BDADDR	1	9	A2	59	Nordic Semiconductor ASA	SPD-BLE0668517
FA:71:89:EF:E6:93	NON-PUBLIC_BDADDR	1	9	A7	59	Nordic Semiconductor ASA	rnet
F5:57:2E:48:96:05	NON-PUBLIC_BDADDR	1	9	B6	59	Nordic Semiconductor ASA	FCAB620360822
E4:D4:97:9B:B6:13	NON-PUBLIC_BDADDR	1	9	B7	59	Nordic Semiconductor ASA	IoT9BB613
C5:09:25:D3:5F:29	NON-PUBLIC_BDADDR	1	9	B7	59	Nordic Semiconductor ASA	IoTVD35F29
C3:3C:6E:74:F7:35	NON-PUBLIC_BDADDR	1	9	B7	59	Nordic Semiconductor ASA	IoT74F735
DF:17:12:E6:7D:A0	NON-PUBLIC_BDADDR	1	9	B7	59	Nordic Semiconductor ASA	IoTVE67DA0
EC:4E:72:76:51:FA	NON-PUBLIC_BDADDR	1	9	B7	59	Nordic Semiconductor ASA	IoT7651FA
F8:6D:F0:81:BA:3C	NON-PUBLIC_BDADDR	1	9	B7	59	Nordic Semiconductor ASA	IoT81BA3C
F4:07:9E:2F:54:C2	NON-PUBLIC_BDADDR	1	A	CC	59	Nordic Semiconductor ASA	NULL
E6:AE:02:49:2A:F4	NON-PUBLIC_BDADDR	1	A	CC	59	Nordic Semiconductor ASA	NULL
6A:58:78:34:90:7F	NON-PUBLIC_BDADDR	1	B	5554	1D	Qualcomm	NULL
EC:81:93:F1:35:AD	Logitech, Inc	0	9	3716	A	Qualcomm Technologies International, Ltd. (QTIL)	NULL
66:1B:11:54:B3:19	NON-PUBLIC_BDADDR	1	6	1D87	A	Qualcomm Technologies International, Ltd. (QTIL)	FIXD
B8:3A:9D:8A:3B:D9	Alarm.com	0	7	D8E1	5D	Realtek Semiconductor Corporation	ALAM (8A:3B:D8)
34:13:43:07:DB:DE	GE Lighting	0	8	E051	5D	Realtek Semiconductor Corporation	AEA76C97625A
78:9C:E7:02:4C:0B	Shenzhen Aikede Technology Co., Ltd	0	8	22BB	211	Telink Semiconductor Co. Ltd	BLE003U
A4:C1:38:73:2E:8B	Telink Semiconductor (Taipei) Co. Ltd.	0	8	22BB	211	Telink Semiconductor Co. Ltd	ihoment_H6110_2E8B
A4:C1:38:38:72:1C	Telink Semiconductor (Taipei) Co. Ltd.	0	8	22BB	211	Telink Semiconductor Co. Ltd	ihoment_H6110_721C
CC:04:B4:0B:C5:21	Select Comfort	0	6	120	D	Texas Instruments Inc.	cc:04:b4:0b:c5:21
B4:60:77:79:D3:CD	Sichuan Changhong Electric Ltd.	0	8	321	D	Texas Instruments Inc.	Sbecb43f15400aaf6C
60:98:66:44:E4:64	Texas Instruments	0	A	213	D	Texas Instruments Inc.	S6c0a7c71fda94e9bC
98:04:ED:C5:CD:68	UNKNOWN_COMP_BY_BDADDR	0	8	321	D	Texas Instruments Inc.	Se019c1365abce9b9C
A0:98:66:0D:EC:BE	UNKNOWN_COMP_BY_BDADDR	0	8	321	D	Texas Instruments Inc.	Se41358d612e55e20C

# Example Data



# **(Link Layer) Sub-Version Number**

**SubVersNr (2 bytes)**

- The vendor gets to make up whatever value they want here!



### 2.4.2.13 LL\_VERSION\_IND

(Link I  
SubVersI

The format of the CtrData field is shown in [Figure 2.23](#).

CtrData		
VersNr (1 octet)	Compld (2 octets)	SubVersNr (2 octets)

- The venci *Figure 2.23: CtrData field of the LL\_VERSION\_IND PDU*

The LL\_VERSION\_IND CtrData consists of three fields:

- VersNr field shall contain the version of the Bluetooth Controller specification (see Bluetooth [Assigned Numbers](#)).
- Compld field shall contain the company identifier of the manufacturer of the Bluetooth Controller (see Bluetooth [Assigned Numbers](#)).

SubVersNr field shall contain a unique value for each implementation or revision of an implementation of the Bluetooth Controller.

# Does SubVersNr Imply OS/Firmware Version?

- **Hypothesis:** SubVersNr will increment per OS/firmware update, and thus can be used to infer the OS/firmware version
  - Conclusion:
    - **Rejected** for Broadcom



# Does SubVersNr Imply OS/Firmware Version?

- From BlueZ 5.66 monitor/packet.c

```
} broadcom_usb_subversion_table[] = {  
  { 0x210b, "BCM43142A0" }, /* 001.001.011 */  
  { 0x2112, "BCM4314A0" }, /* 001.001.018 */  
  { 0x2118, "BCM20702A0" }, /* 001.001.024 */  
  { 0x2126, "BCM4335A0" }, /* 001.001.038 */  
  { 0x220e, "BCM20702A1" }, /* 001.002.014 */  
  { 0x230f, "BCM4354A2" }, /* 001.003.015 */  
  { 0x4106, "BCM4335B0" }, /* 002.001.006 */  
  { 0x410e, "BCM20702B0" }, /* 002.001.014 */  
  { 0x6109, "BCM4335C0" }, /* 003.001.009 */  
  { 0x610c, "BCM4354" }, /* 003.001.012 */
```

# Oh right...I remember something now...

- InternalBlue has firmware files per Broadcom chip, and they're ordered by numbers that look like those SubVersions!

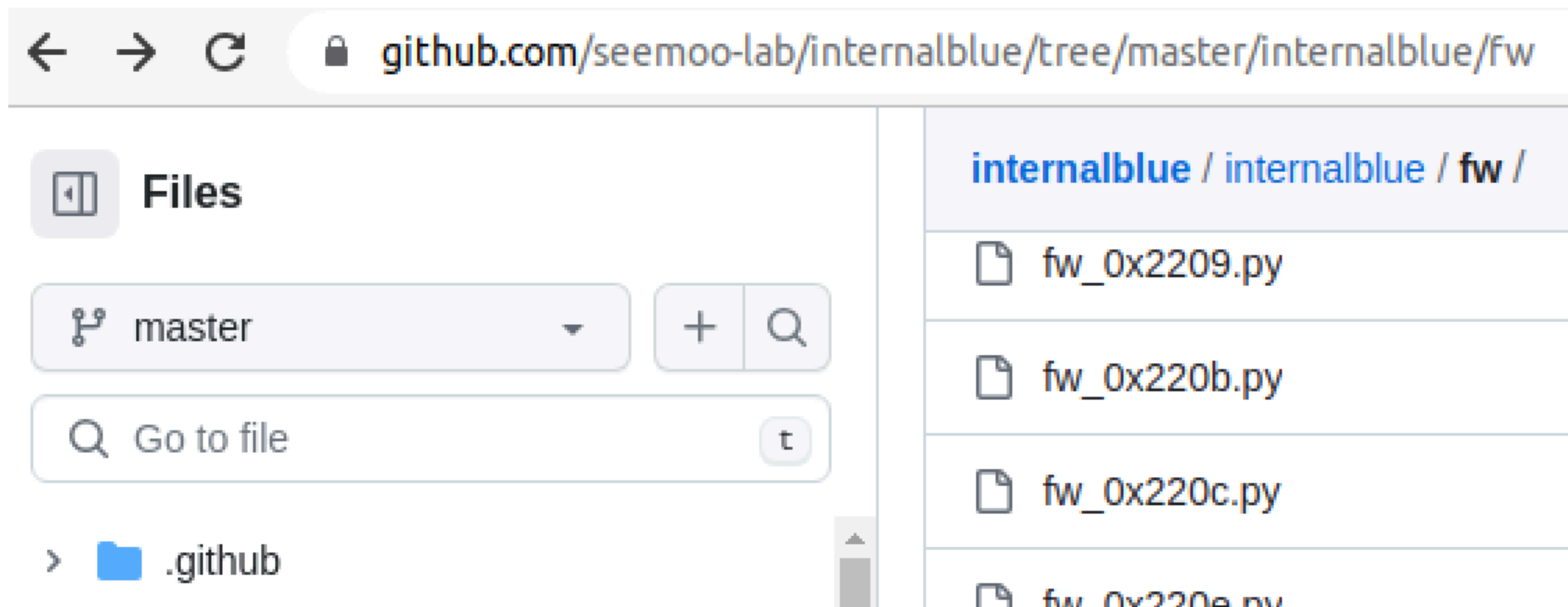

The screenshot shows a web browser window displaying a GitHub repository. The address bar contains the URL `github.com/seemoo-lab/internalblue/tree/master/internalblue/fw`. The page content is divided into a left sidebar and a main file list area.

**Left Sidebar:**

- Files** (with a folder icon)
- Branch selector: `master` (with a dropdown arrow)
- Buttons: `+` (Add) and `Q` (Search)
- Search bar: `Go to file` (with a magnifying glass icon and a `t` button)
- Folder: `> .github` (with a blue folder icon)

**Main File List:**

- `internalblue / internalblue / fw /` (highlighted header)
- `fw_0x2209.py` (file icon)
- `fw_0x220b.py` (file icon)
- `fw_0x220c.py` (file icon)
- `fw_0x220e.py` (file icon)





C

.

 fw\_0x2033.py

 fw\_0x203a.py

 fw\_0x2056.py

 fw\_0x21a9.py

 fw\_0x21d0.py

 fw\_0x2209.py

 fw\_0x220b.py

 fw\_0x220c.py

 fw\_0x220e.py

 fw\_0x2230.py

 fw\_0x240f.py

 fw\_0x3032.py

 fw\_0x4196.py

 fw\_0x4208.py

 fw\_0x420e.py

 fw\_0x420e\_iphone.py

 fw\_0x4228.py

 fw\_0x422a.py

 fw\_0x6103.py

 fw\_0x6109.py

 fw\_0x6119.py



C

- fw\_0x2033.py
- fw\_0x203a.py
- fw\_0x2056.py
- fw\_0x21a9.py
- fw\_0x21d0.py
- fw\_0x2209.py

- fw\_0x4196.py
- fw\_0x4208.py
- fw\_0x420e.py
- fw\_0x420e\_iphone.py
- fw\_0x4228.py
- fw\_0x422a.py
- fw\_0x6103.py
- fw\_0x6109.py**
- fw\_0x6119.py

```
} broadcom_usb_subversion_table[] = {  
  { 0x210b, "BCM43142A0" }, /* 001.001.011 */  
  { 0x2112, "BCM4314A0" }, /* 001.001.018 */  
  { 0x2118, "BCM20702A0" }, /* 001.001.024 */  
  { 0x2126, "BCM4335A0" }, /* 001.001.038 */  
  { 0x220e, "BCM20702A1" }, /* 001.002.014 */  
  { 0x230f, "BCM4354A2" }, /* 001.003.015 */  
  { 0x4106, "BCM4335B0" }, /* 002.001.006 */  
  { 0x410e, "BCM20702B0" }, /* 002.001.014 */  
  { 0x6109, "BCM4335C0" }, /* 003.001.009 */  
  { 0x610c, "BCM4354" }, /* 003.001.012 */  
}
```



# Broadcom

- So at least for Broadcom, the SubVersion is used to store a specific silicon chip (& *stepping revision*) information!
- ***The ideal ChipPrint!*** 🎉
- (I would have preferred a VersionPrint, but oh well...)

# Does SubVersNr Imply OS/Firmware Version?

- **Hypothesis:** SubVersNr will increment per OS/firmware update, and thus can be used to infer the OS/firmware version
- Conclusion:
  - Weak reject for MediaTek, which seems to default to SubVersNr == 0, but where there are a range of versions seen, which probably then depends on the device maker's behavior
  - *Requires more investigation*



# Does SubVersNr Imply OS/Firmware Version?

- **Hypothesis:** SubVersNr will increment per OS/firmware update, and thus can be used to infer the OS/firmware version
- Overall Conclusion:
  - Requires more investigation!
  - Fundamentally requires hands on with a device + manually updating firmware and observing how the sub-version-number changes

# 2thprint by Link Layer Packet Combinations





# Version Information is not the only game in town

- If we want to be more nmap-OS-fingerprint-like, it makes sense to hit the target with multiple packet types, potentially in different orders, and see how it responds
- **LMP packet types:** LMP\_features\_req, LMP\_features\_req\_ext, LMP\_version\_req, LMP\_name\_req, LMP\_switch\_req, LMP\_ping\_req, LMP\_encryption\_key\_size\_req, *malformed* LMP\_features\_req, *malformed* LMP\_features\_req\_ext
- **BLE LL packet types:** LL\_VERSION\_IND, LL\_LENGTH\_REQ, LL\_PING\_REQ, LL\_FEATURE\_REQ



# "malformed" LMP\_features\_ext\_req?

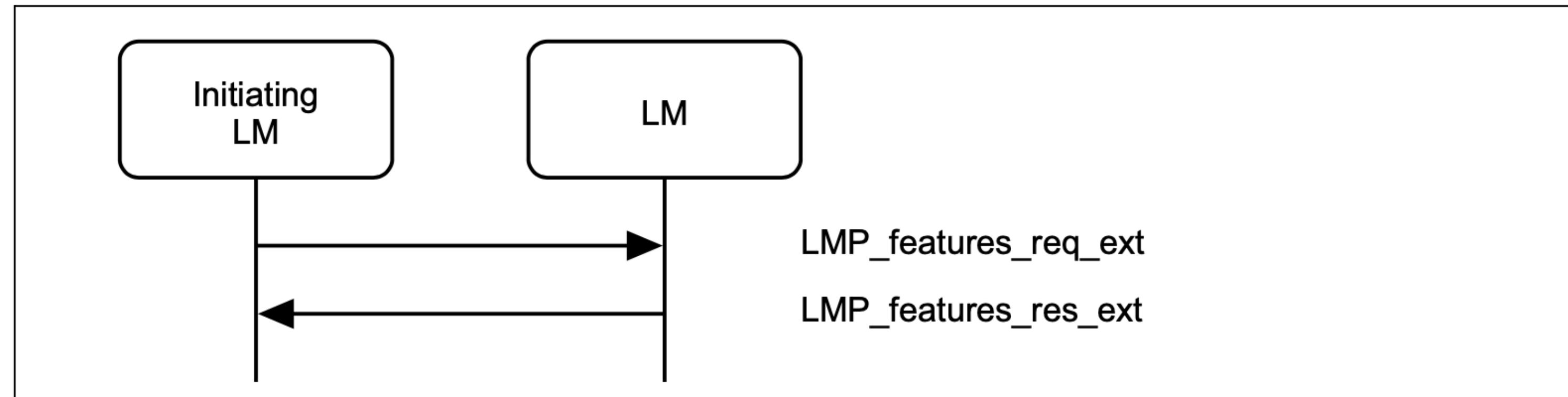

Sequence 79: Request for extended features



# "malformed" LMP\_features\_ext\_req?

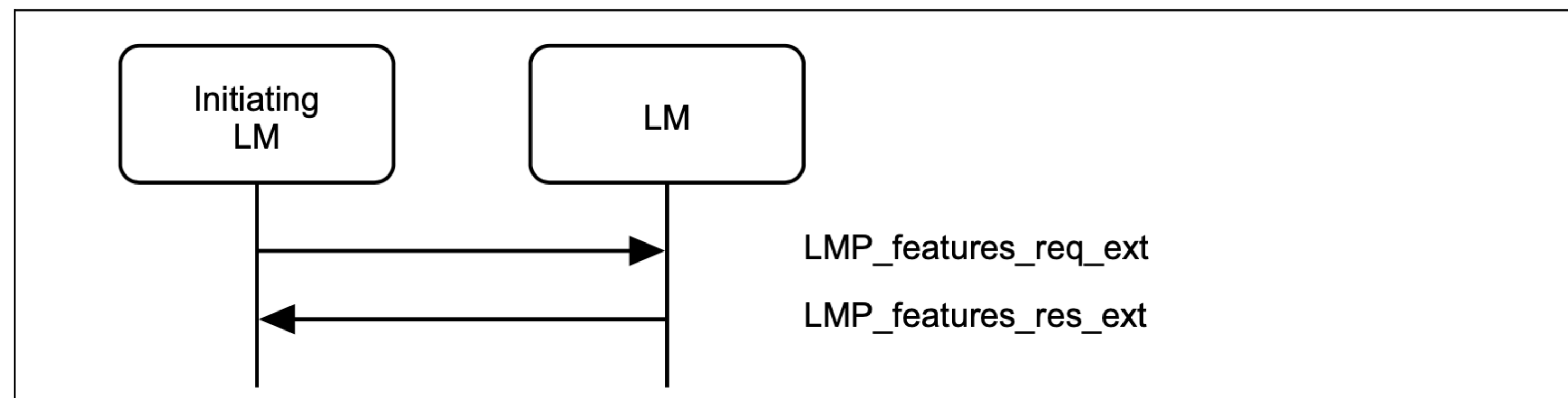

Sequence 79: Request for extended features

## 3.3 FEATURE MASK DEFINITION

The features are represented as a bit mask when they are transferred in LMP messages. For each feature a single bit is specified which shall be set to 1 if the feature is supported and set to 0 otherwise. The single exception is the flow control lag which is coded as a 3 bit field with the least significant bit in byte 2 bit 4 and the most significant bit in byte 2 bit 6. All removed, unknown, or unassigned feature bits shall be set to 0 and ignored upon receipt.

No.	Supported feature	Byte	Bit
0	3 slot packets	0	0
1	5 slot packets	0	1
2	Encryption	0	2



"malform

?)?

3	Slot offset	0	5
4	Timing accuracy	0	4
5	Role switch	0	5
6	Hold mode	0	6
7	Sniff mode	0	7
8	Park state	1	0
9	Power control requests	1	1
10	Channel quality driven data rate (CQDDR)	1	2
11	SCO link	1	3

...

No.	Supported feature	Byte	Bit
57	Inquiry TX Power Level	7	1
58	Enhanced Power Control	7	2
59	Reserved	7	3
60	Reserved	7	4
61	Reserved	7	5
62	Reserved	7	6
63	Extended features	7	7

Table 3.2: Feature mask definitions (page 0)



"malform

?)?

3	Slot offset	0	5
4	Timing accuracy	0	4
5	Role switch	0	5
6	Hold mode	0	6
7	Sniff mode	0	7
8	Park state	1	0
9	Power control requests	1	1
10	Channel quality driven data rate (CQDDR)	1	2
11	SCO link	1	3

...

No.	Supported feature	Byte	Bit
57	Inquiry TX Power Level	7	1
58	Enhanced Power Control	7	2
59	Reserved	7	3
60	Reserved	7	4
61	Reserved	7	5
62	Reserved	7	6
63	Extended features	7	7

Table 3.2: Feature mask definitions (page 0)



No.	Supported Feature	Byte	Bit
64	Secure Simple Pairing (Host Support)	0	0
65	LE Supported (Host)	0	1
66	Simultaneous LE and BR/EDR to Same Device Capable (Host)	0	2
67	Secure Connections (Host Support)	0	3

Table 3.3: Extended feature mask definition (page 1)

No.	Supported Feature	Byte	Bit
128	Connectionless Slave Broadcast – Master Operation	0	0
129	Connectionless Slave Broadcast – Slave Operation	0	1
130	Synchronization Train	0	2
131	Synchronization Scan	0	3
132	Inquiry Response Notification Event	0	4
133	Generalized interlaced scan	0	5
134	Coarse Clock Adjustment	0	6
135	Reserved	0	7
136	Secure Connections (Controller Support)	1	0
137	Ping	1	1
138	Reserved	1	2
139	Train nudging	1	3

Table 3.4: Extended feature mask definition (page 2)



No.	Supported Feature	Byte	Bit
64	Secure Simple Pairing (Host Support)	0	0
65	LE Supported (Host)	0	1
66	Simultaneous LE and BR/EDR to Same Device Capable (Host)	0	2
67	Secure Connections (Host Support)	0	3

Table 3.3: Extended feature mask definition (page 1)

No.	Supported Feature	Byte	Bit
128	Connectionless Slave Broadcast – Master Operation	0	0
129	Connectionless Slave Broadcast – Slave Operation	0	1
130	Synchronization Train	0	2
131	Synchronization Scan	0	3
132	Inquiry Response Notification Event	0	4
133	Generalized interlaced scan	0	5
134	Coarse Clock Adjustment	0	6
135	Reserved	0	7
136	Secure Connections (Controller Support)	1	0
137	Ping	1	1
138	Reserved	1	2
139	Train nudging	1	3

Table 3.4: Extended feature mask definition (page 2)



# Pick a page, any page...

M/O	PDU	Contents
M	LMP_features_req	features
M	LMP_features_res	features
O(63)	<b>LMP_features_req_ext</b>	features page max supported page extended features
O(63)	LMP_features_res_ext	features page max supported page extended features



"The LMP\_features\_req\_ext PDU contains a feature page index that specifies which page is requested and the contents of that page for the requesting device. Pages are numbered from 0-255 with page 0 corresponding to the normal features mask. "

Table 4.27: PDUs used for features request

# Pick a page, any page



You should *never* request a feature page > their max supported page OR the max page in the version of the spec that they conform to.  
 E.g. Spec 4.2 only has pages 0, 1, 2.  
 So what happens if you request 3...or 255?

M/O	PDU	Contents
M	LMP_features_req	features
M	LMP_features_res	features
O(63)	LMP_features_req_ext	features page max supported page extended features
O(63)	LMP_features_res_ext	features page max supported page extended features

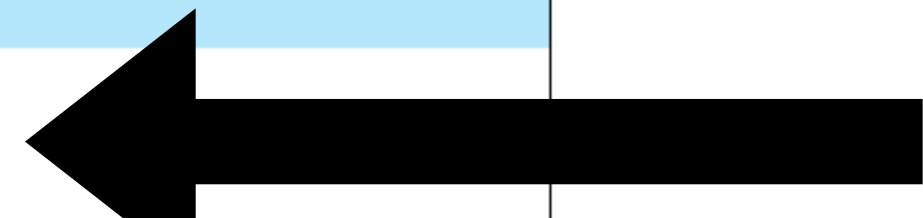

"The LMP\_features\_req\_ext PDU contains a feature page index that specifies which page is requested and the contents of that page for the requesting device. Pages are numbered from 0-255 with page 0 corresponding to the normal features mask. "

Table 4.27: PDUs used for features request

# How to Send Packets?

- Sweyntooth[1] (2020, BLE-only) & Braktooth[2] (2022, BTC-only)
  - Provide a way in Python and C respectively to create & send arbitrary link-layer packets in an arbitrary order

[1] <https://asset-group.github.io/disclosures/sweyntooth/>

[2] <https://asset-group.github.io/disclosures/braktooth/>





# DATA ANALYSIS ETA WEN?

- Finding "weird packets/combinations" was the original idea for 2thprinting...and yet...I haven't actually analyzed this data yet \\_(ツ)\_/. Why tho?
- 1) it *feels* like I haven't found the right balance yet between speed and useful signal
  - I'm prioritizing 2thprinting mechanisms that are as fast as possible, so they can be used against moving targets
    - Reinvocation of Braktooth/Sweyntooth adds 5+ seconds of overhead to every 2thprinting attempt
- 2) I want known *reference chips* to compare this data to before I start asserting "this packet combination result is indicative of vendor X"
  - Current research intern project

# 2thprint by Manufacturer-Specific Data



or





# 2thprint by Manufacturer-Specific Data (MSD): Company ID (CID)

Supplement to the Bluetooth Core Specification | v11, Part A

page 12

*Data Types Specification*



## 1 DATA TYPES DEFINITIONS AND FORMATS

This part defines the basic data types used for Extended Inquiry Response (EIR), Advertising Data (AD), Scan Response Data (SRD), Additional Controller Advertising Data (ACAD), and OOB data blocks. Additional data types may be defined in profile specifications.

Each data type shall only be used in accordance with the requirements specified in [Table 1.1](#).

Data type	Context				
	EIR	AD	SRD	ACAD	OOB
Service UUID	O	O	O	O	O
Local Name	C.1	C.1	C.1	X	C.1
Flags	C.1	C.1	X	X	C.1
Manufacturer Specific Data	O	O	O	O	O

- BLE Advertisements and BTC Extended Inquiry Response packets can include MSD data where the manufacturer can *mostly* put whatever they want



# 2thprint by Manufacturer-Specific Data (MSD): Company ID (CID)

Supplement to the Bluetooth Core Specification | v11, Part A

page 12

*Data Types Specification*



## 1 DATA TYPES DEFINITIONS AND FORMATS

This part defines the basic data types used for Extended Inquiry Response (EIR), Advertising Data (AD), Scan Response Data (SRD), Additional Controller Advertising Data (ACAD), and OOB data blocks. Additional data types may be defined in profile specifications.

Each data type shall only be used in accordance with the requirements specified in [Table 1.1](#).

Data type	Context				
	EIR	AD	SRD	ACAD	OOB
Service UUID	O	O	O	O	O
Local Name	C.1	C.1	C.1	X	C.1
Flags	C.1	C.1	X	X	C.1
Manufacturer Specific Data	O	O	O	O	O

- BLE Advertisements and BTC Extended Inquiry Response packets can include MSD data where the manufacturer can *mostly* put whatever they want



# 2thprint by Manufacturer-Specific Data (MSD): Company ID (CID)

*Data Types Specification*



- They's \*supposed\* to put their company's assigned number in the first 2 bytes, but not everyone does...
- Also, some put the company ID as little-endian, and some as big-endian, and some use both!

## 1.4 MANUFACTURER SPECIFIC DATA

### 1.4.1 Description

The Manufacturer Specific data type is used for manufacturer specific data. The first two data octets shall contain a company identifier from [Assigned Numbers](#). The interpretation of any other octets within the data shall be defined by the manufacturer specified by the company identifier.

### 1.4.2 Format

Data Type	Description
«Manufacturer Specific Data» <i>uint16</i> , which may be followed by <i>struct</i>	The first value contains the Company Identifier Code. Any remainder contains manufacturer specific data.

Table 1.5: Manufacturer Specific data type



# 2thprint by Manufacturer-Specific Data (MSD): Company ID (CID)

*Data Types Specification*



- They's \*supposed\* to put their company's assigned number in the first 2 bytes, but not everyone does...
- Also, some put the company ID as little-endian, and some as big-endian, and some use both!

## 1.4 MANUFACTURER SPECIFIC DATA

### 1.4.1 Description

The Manufacturer Specific data type is used for manufacturer specific data. The first two data octets shall contain a company identifier from [Assigned Numbers](#). The interpretation of any other octets within the data shall be defined by the manufacturer specified by the company identifier.

### 1.4.2 Format

Data Type	Description
«Manufacturer Specific Data» <i>uint16</i> , which may be followed by <i>struct</i>	The first value contains the Company Identifier Code. Any remainder contains manufacturer specific data.

Table 1.5: Manufacturer Specific data type



# 2thprint by Manufacturer-Specific Data (MSD): Company ID (CID)

Data Types Specification



- They's \*supposed\* to put their company's assigned number in the first 2 bytes, but not everyone does...
- Also, some put the company ID as little-endian, and some as big-endian, and some use both!

## 1.4 MANUFACTURER SPECIFIC DATA

### 1.4.1 Description

The Manufacturer Specific data type is used for manufacturer specific data. The first two data octets shall contain a company identifier from [Assigned Numbers](#). The interpretation of any other octets within the data shall be defined by the manufacturer specified by the company identifier.

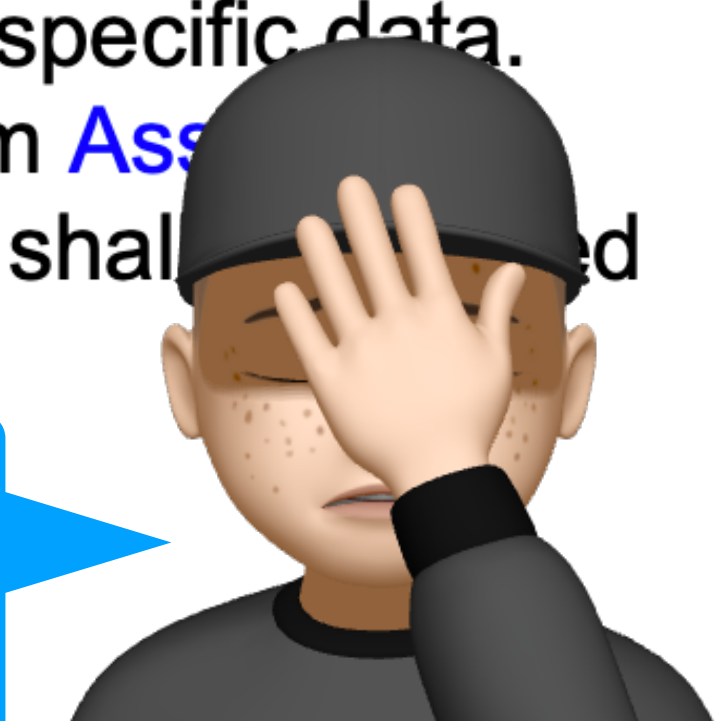

It doesn't say what endianness it should use!

### 1.4.2 Format

Data Type	Description
«Manufacturer Specific Data» <i>uint16</i> , which may be followed by <i>struct</i>	The first value contains the Company Identifier Code. Any remainder contains manufacturer specific data.

Table 1.5: Manufacturer Specific data type



# Endianness info from BT Spec 4.0!

Lost in BT Spec 4.2 when they created the Core Specification Supplement doc?

## 8.1 EIR DATA TYPE DEFINITIONS

This section defines the basic EIR data types. Additional EIR data types may be defined in profile specifications.

All EIR data type values are listed in the Bluetooth [Assigned Numbers](#) document.

All numerical multi-byte entities and values associated with the following data types shall use little-endian byte order.





# Top 20 Vendors for BTC MSD data

BTC - 2023-10-26

device_BT_CID	company_name	frequency	
0x8700	Garmin International (wrong-endian)	5942	✘
0x4C00	Apple, Inc. (wrong-endian)	2487	🍪
0x1D	Qualcomm	2437	🍪
0xFF19	Samsung Electronics Co. Ltd. (just wacky)	1938	🍪
0xF	Broadcom Corporation	950	🍪
0x75	Samsung Electronics Co. Ltd.	879	🍪
0x7500	Samsung Electronics Co.,Ltd (wrong-endian)	278	🍪
0xD906	Shanghai Mountain View Silicon Co.,Ltd. (wrong-endian)	274	🍪
0x3E0	Actions (Zhuhai) Technology Co., Limited	97	🍪
0x4C	Apple, Inc.	45	🍪
0x27D	HUAWEI Technologies Co., Ltd.	43	✘
0xA	Qualcomm Technologies International, Ltd. (QTIL)	32	🍪
0xA02	Ayxon-Dynamics GmbH	14	✘
0x200	Verifone Systems Pte Ltd. Taiwan Branch	7	✘
0x0	Ericsson AB	7	✘
0xA00	Ampler Bikes OU (wrong-endian Qualcomm?)	6	✘
0x5F0	beken	6	🍪
0x850	Yealink (Xiamen) Network Technology Co.,LTD	5	✘
0x18C	Wilo SE	3	✘
0x67	GN Audio A/S	3	✘

...



# Top 20 Vendors for BLE MSD data

BLE - 2023-10-26

device_BT_CID	company_name		frequency
0x4C	Apple, Inc.	🍪	9503999
0x6	Microsoft	❌	94967
0x75	Samsung Electronics Co. Ltd.	🍪	83182
0x11B	Hewlett Packard Enterprise	❌	18899
0x183	Walt Disney	❌	14073
0x3	IBM Corp.	❌	11937
0x87	Garmin International, Inc.	❌	10150
0x131	Cypress Semiconductor	🍪	7872
0x0	Ericsson AB	❌	7547
0x171	Amazon.com Services LLC	❌	6926
0x57	Harman International Industries, Inc.	❌	6424
0x87F	Phillips Connect Technologies LLC	❌	5735
0x12D	Sony Corporation	❌	5265
0xE0	Google	❌	4370
0x310	SGL Italia S.r.l.	❌	3730
0xB01	RESIDEO TECHNOLOGIES, INC.	❌	3608
0xA01	Cleveron AS	❌	3139
0x157	Anhui Huami Information Technology Co., Ltd.	❌	2657
0x65	HP, Inc.	❌	2412
0x4C00	Apple, Inc. (wrong-endian)	🍪	1946

...

# 2thprint by GATT



\* I would tend to argue though that GATT UUID16/UUID128s included in ADV\_IND or SCAN\_RSP are passive and semi-passive respectively



# 2thprint by GATT

## *GATTPrint*

- **Generic Attribute Profile (GATT)** is a sort of weird thing that's built on top of Attribute Protocol (ATT), which is the actual protocol for sending & receiving data
- Mostly used on BLE, though it can technically be used on BTC devices too
- You can *theoretically* get ALL the types of information through GATT!

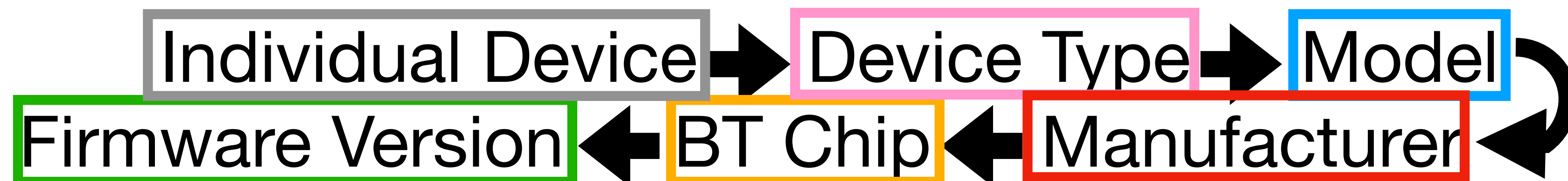



# 2thprint by GATT

## *GATTPrint*

- **Generic Attribute Profile (GATT)** is a sort of weird thing that's built on top of Attribute Protocol (ATT), which is the actual protocol for sending & receiving data
- Mostly used on BLE, though it can technically be used on BTC devices too
- You can *theoretically* get ALL the types of information through GATT!

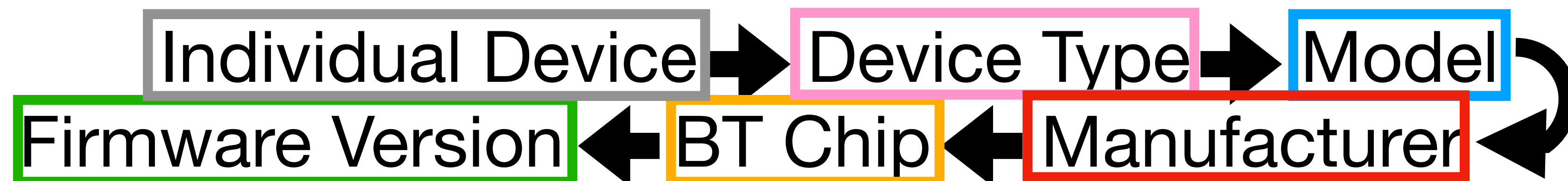



# 2thprint by GATT

## *GATTPrint*

- **Generic Attribute Profile (GATT)** is a sort of weird thing that's built on top of Attribute Protocol (ATT), which is the actual protocol for sending & receiving data
- Mostly used on BLE, though it can technically be used on BTC devices too
- You can *theoretically* get ALL the types of information through GATT!

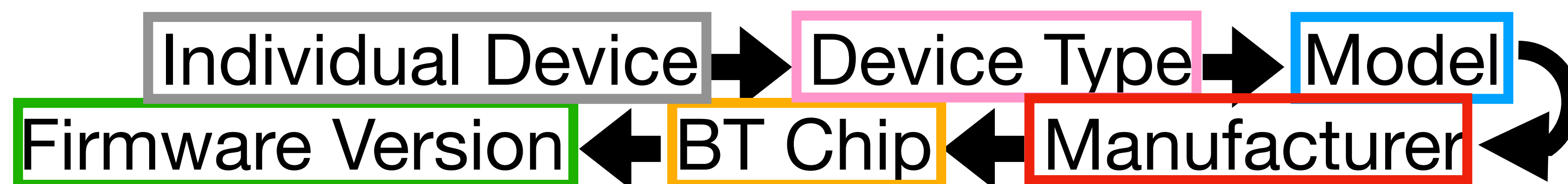



# GATT on Phones

- When you open a Bluetooth scanner app like LightBlue or BluefruitConnect on your phone, and they show you information, usually that is GATT information
- This is from BluefruitConnect

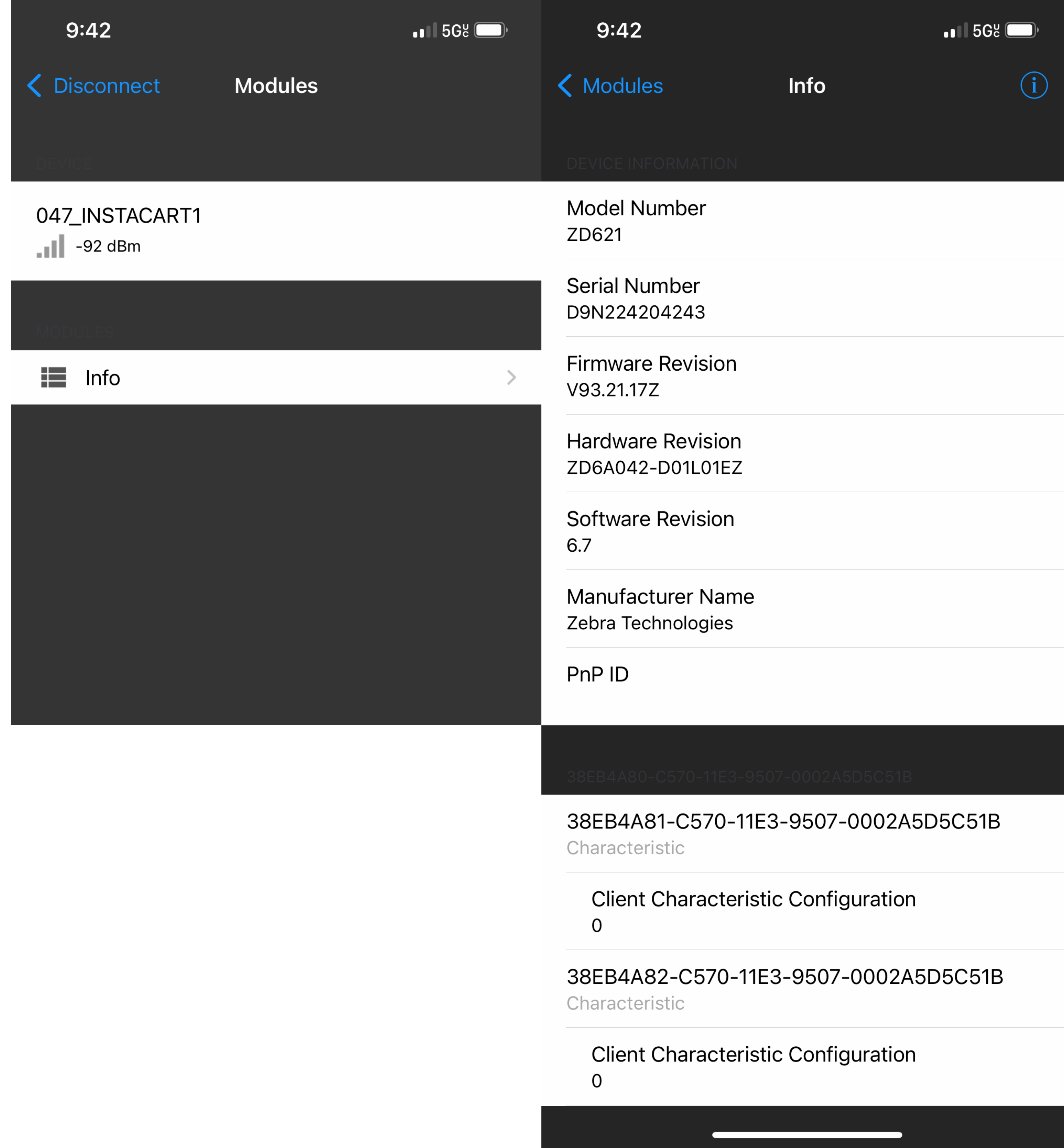



# GATT on Phones

- When you open a Bluetooth scanner app like LightBlue or BluefruitConnect on your phone, and they show you information, usually that is GATT information
- This is from BluefruitConnect

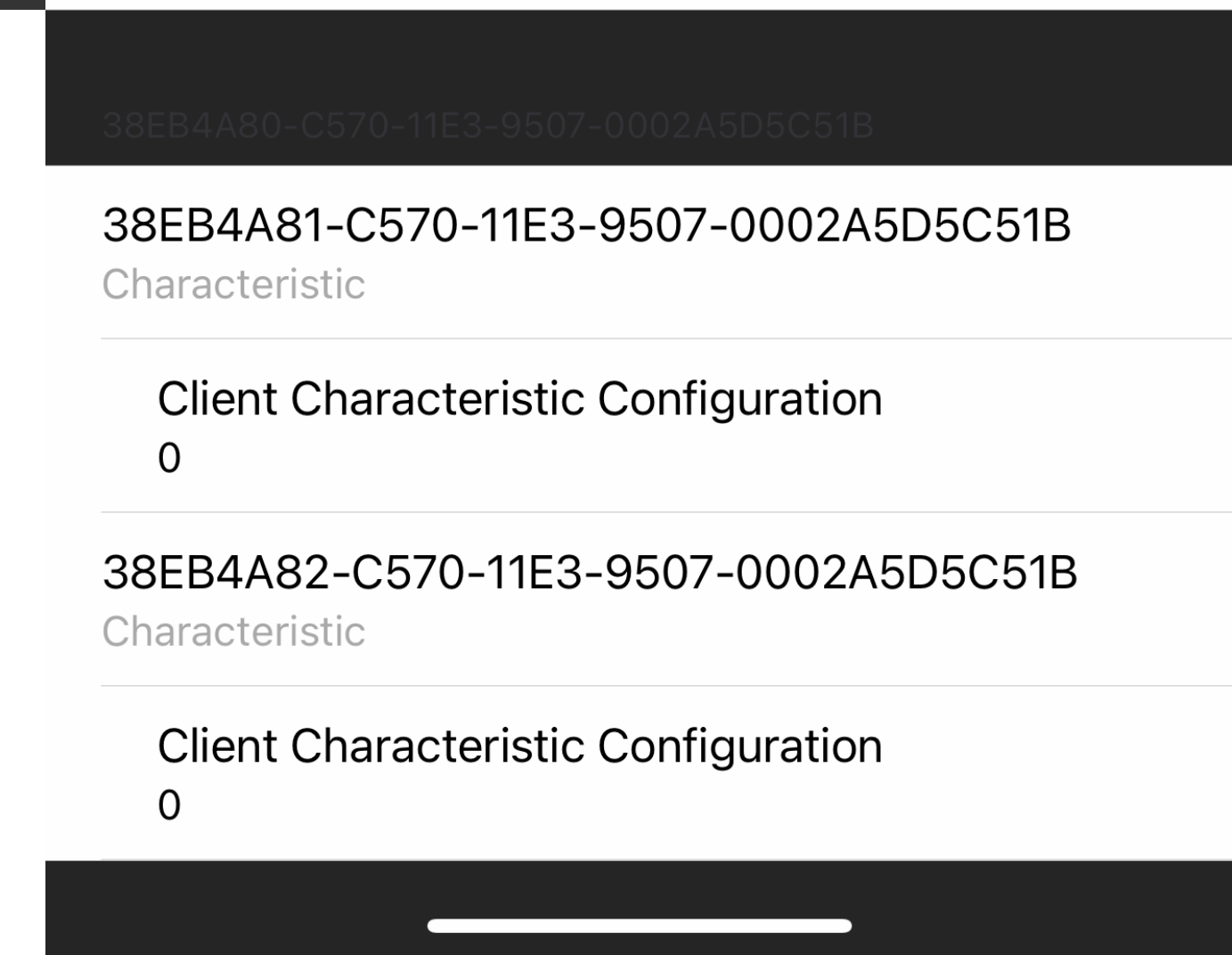
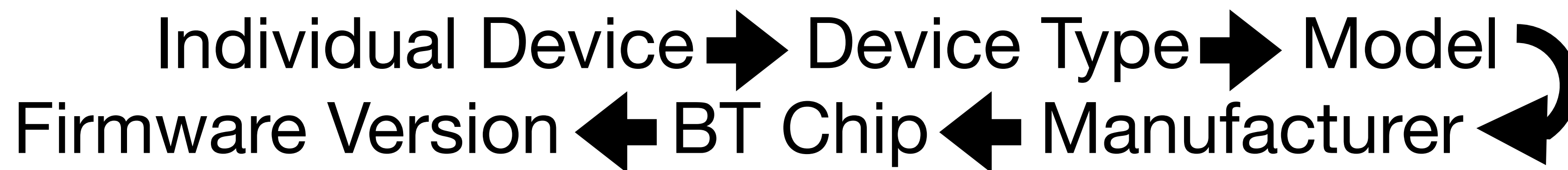
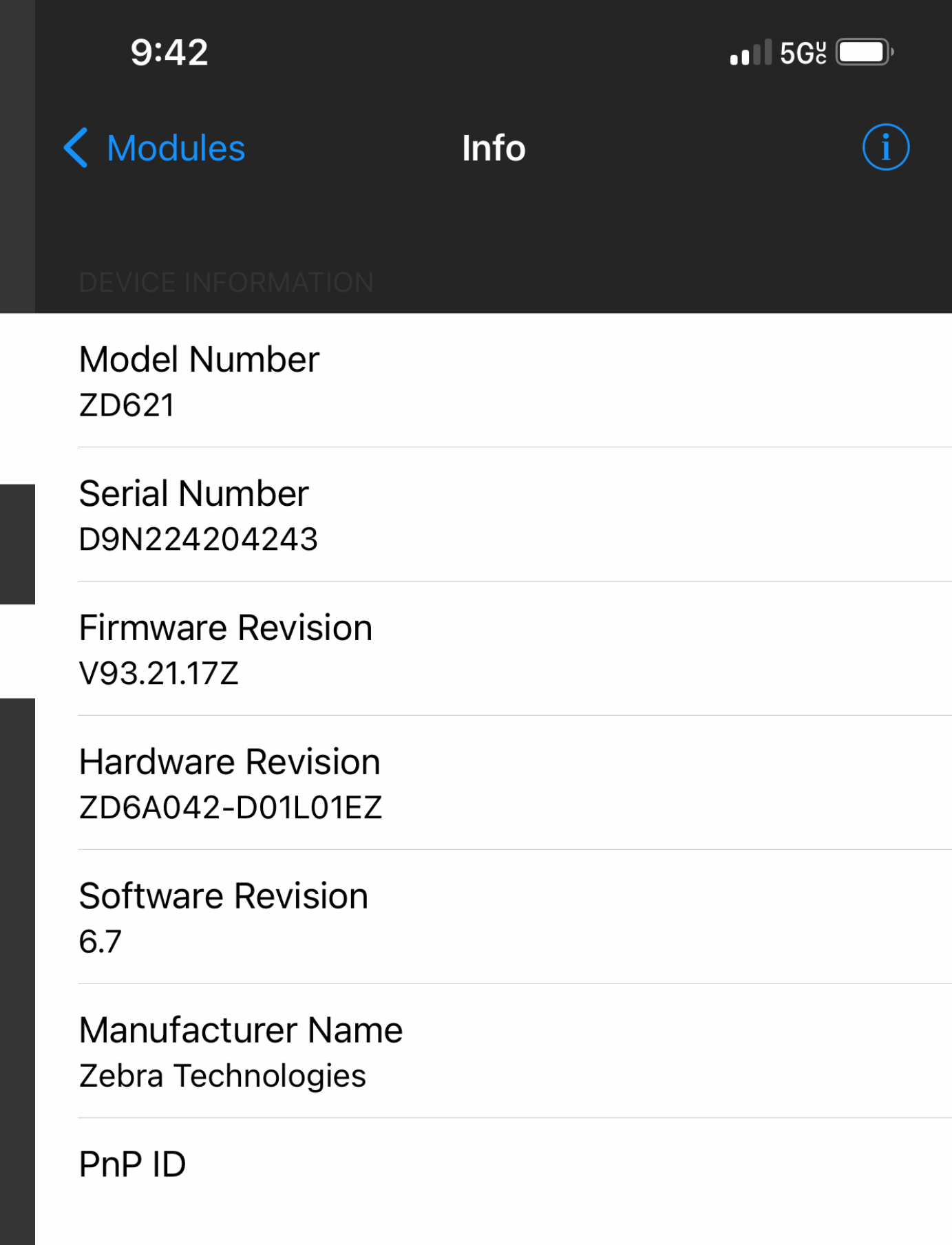
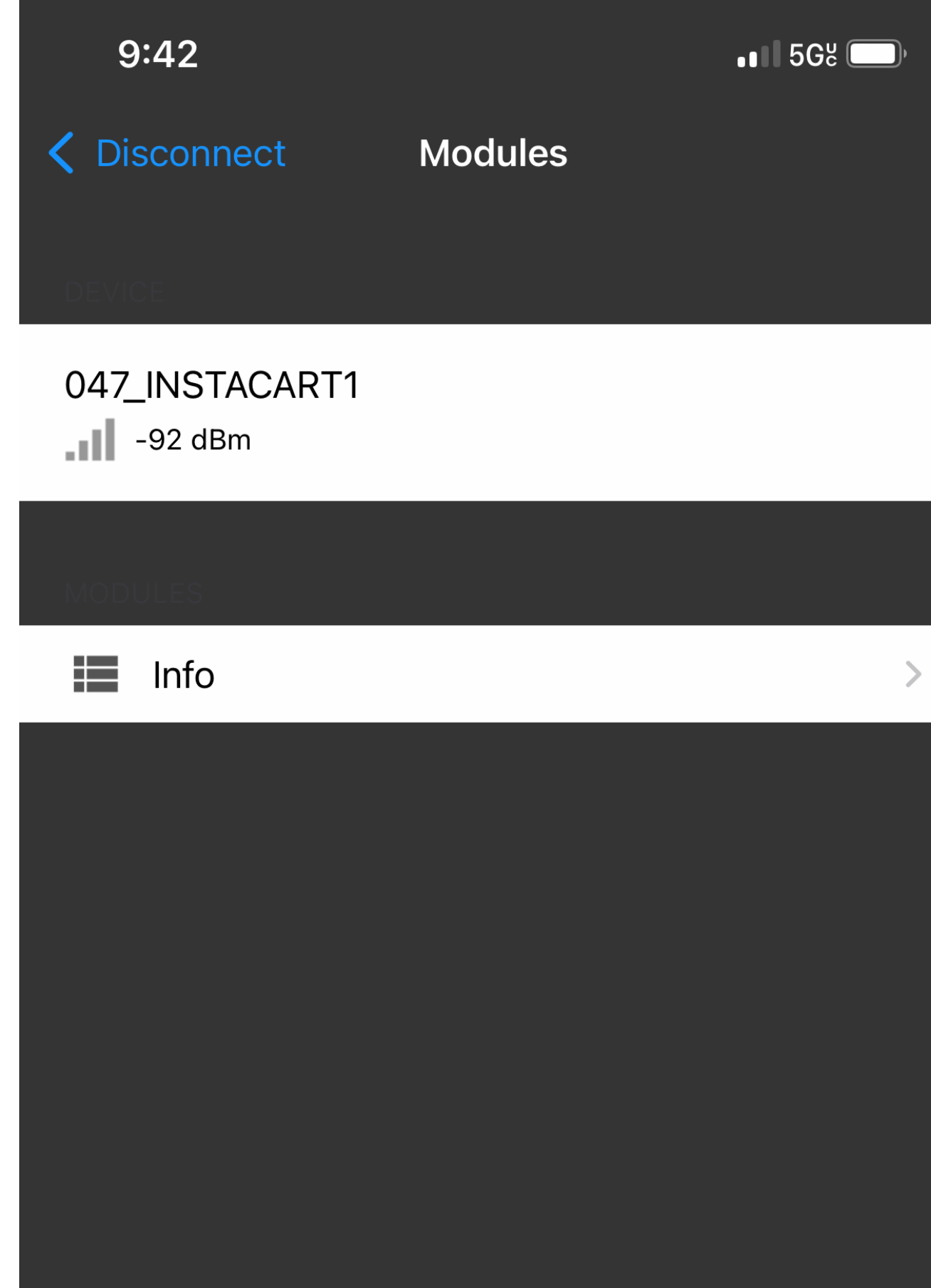





# GATT on Phones

- When you open a Bluetooth scanner app like LightBlue or BluefruitConnect on your phone, and they show you information, usually that is GATT information
- This is from BluefruitConnect

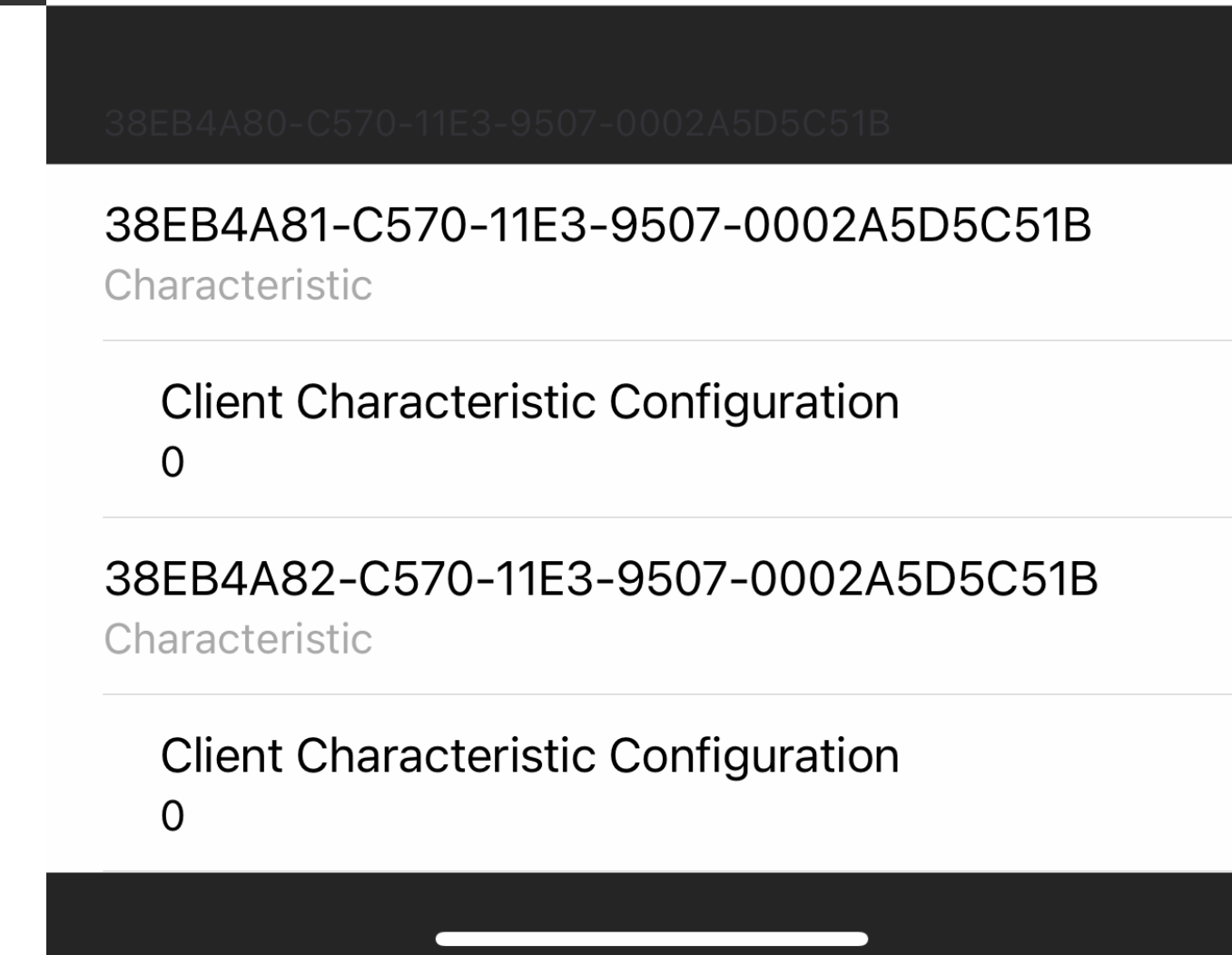
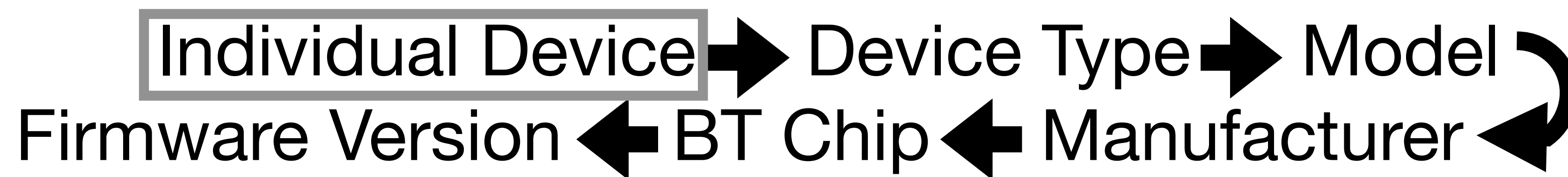
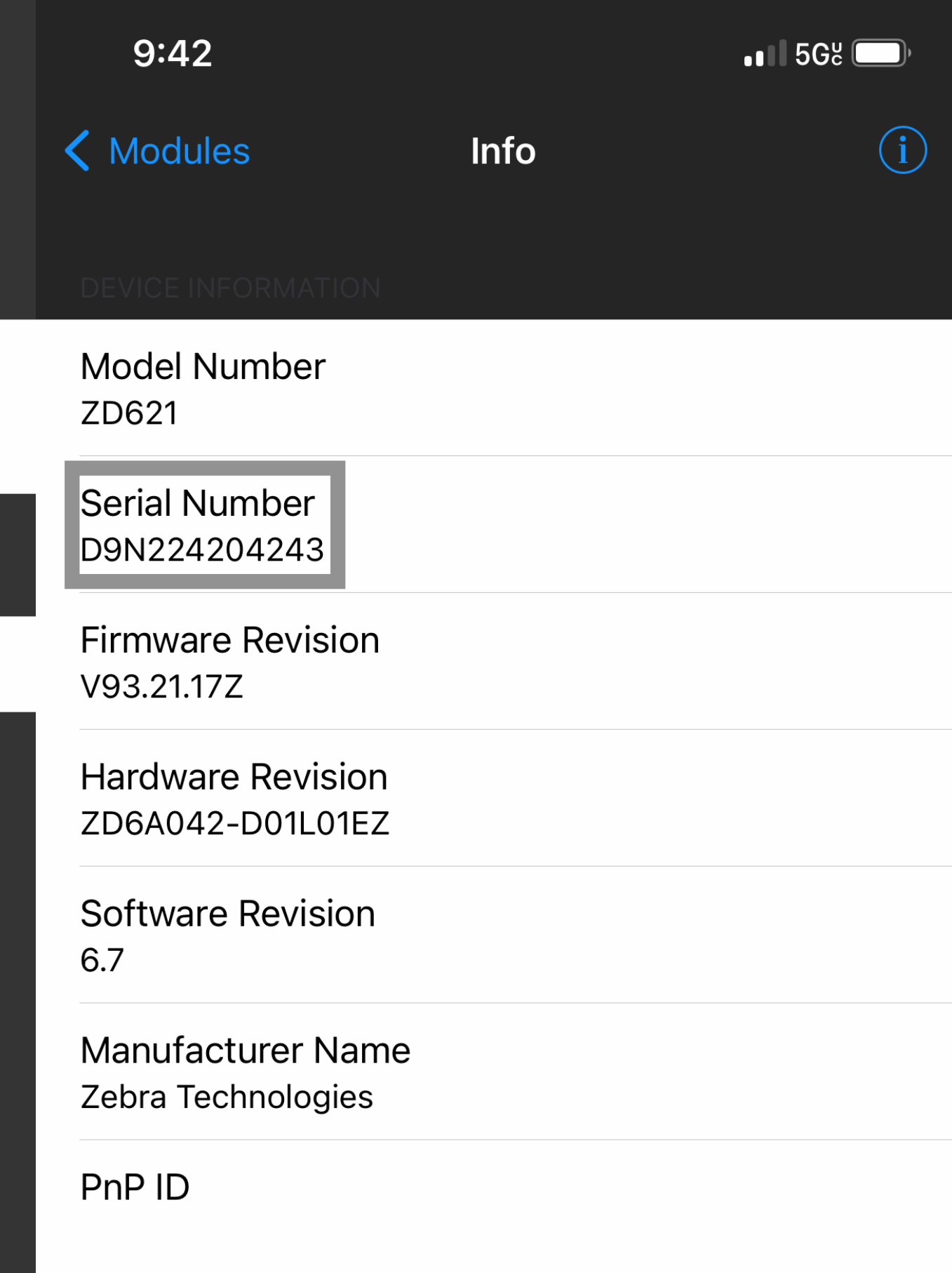
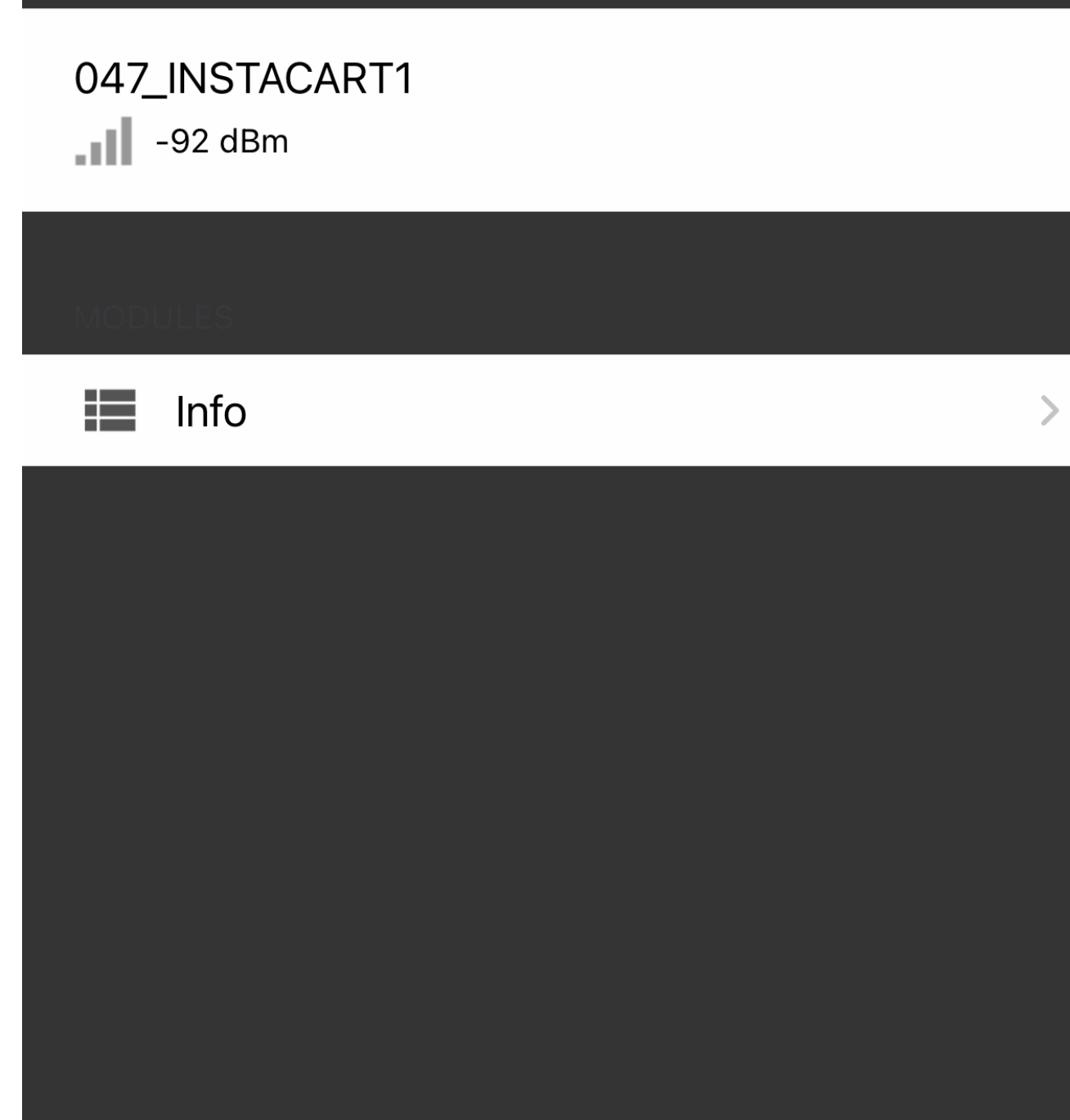
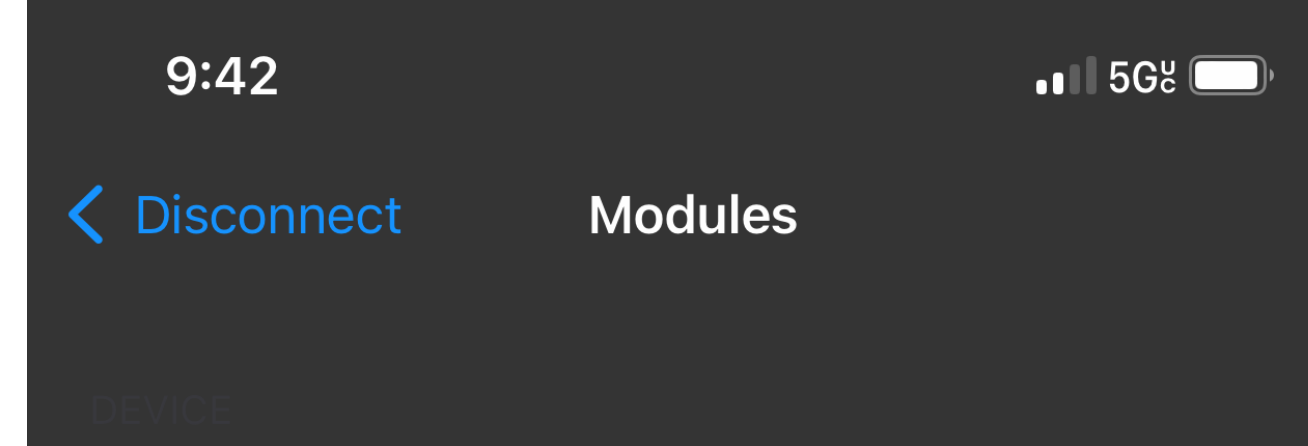



# GATT on Phones

- When you open a Bluetooth scanner app like LightBlue or BluefruitConnect on your phone, and they show you information, usually that is GATT information
- This is from BluefruitConnect

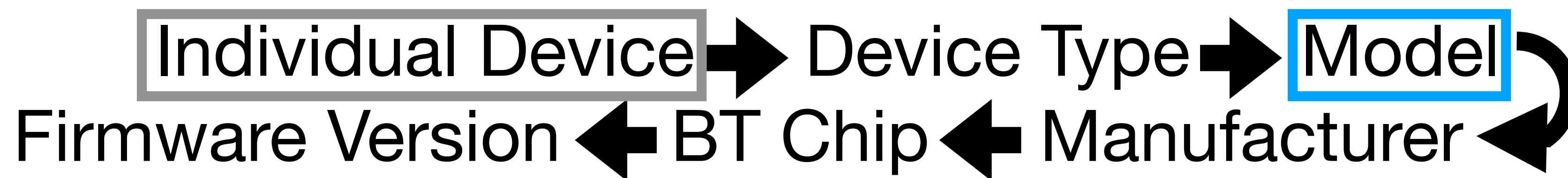
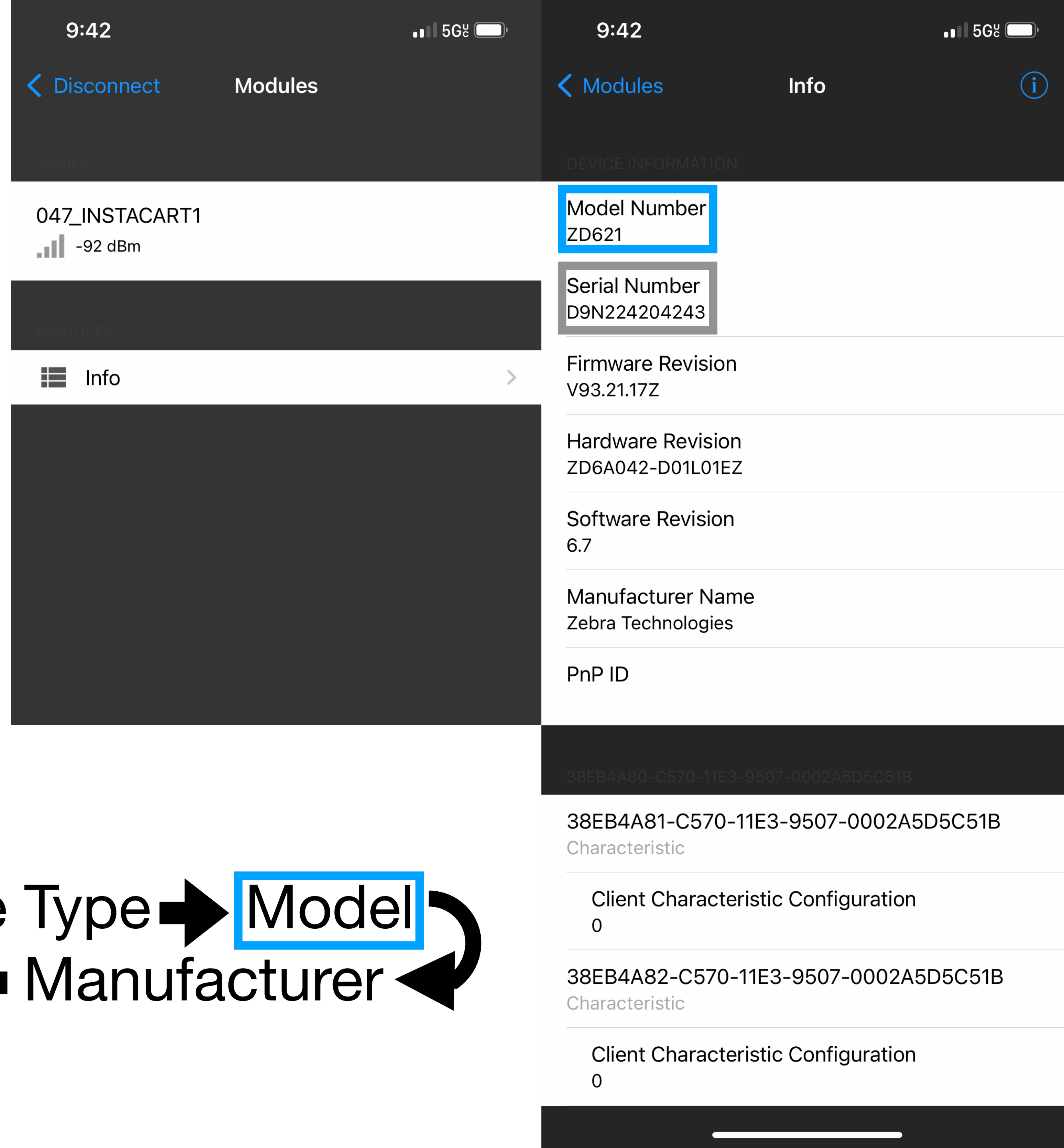



# GATT on Phones

- When you open a Bluetooth scanner app like LightBlue or BluefruitConnect on your phone, and they show you information, usually that is GATT information
- This is from BluefruitConnect

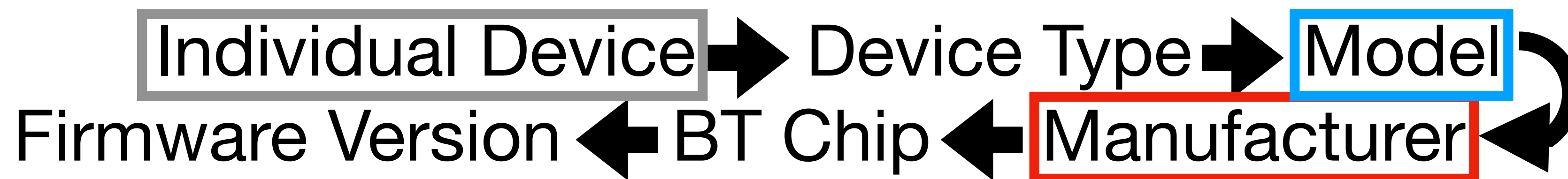
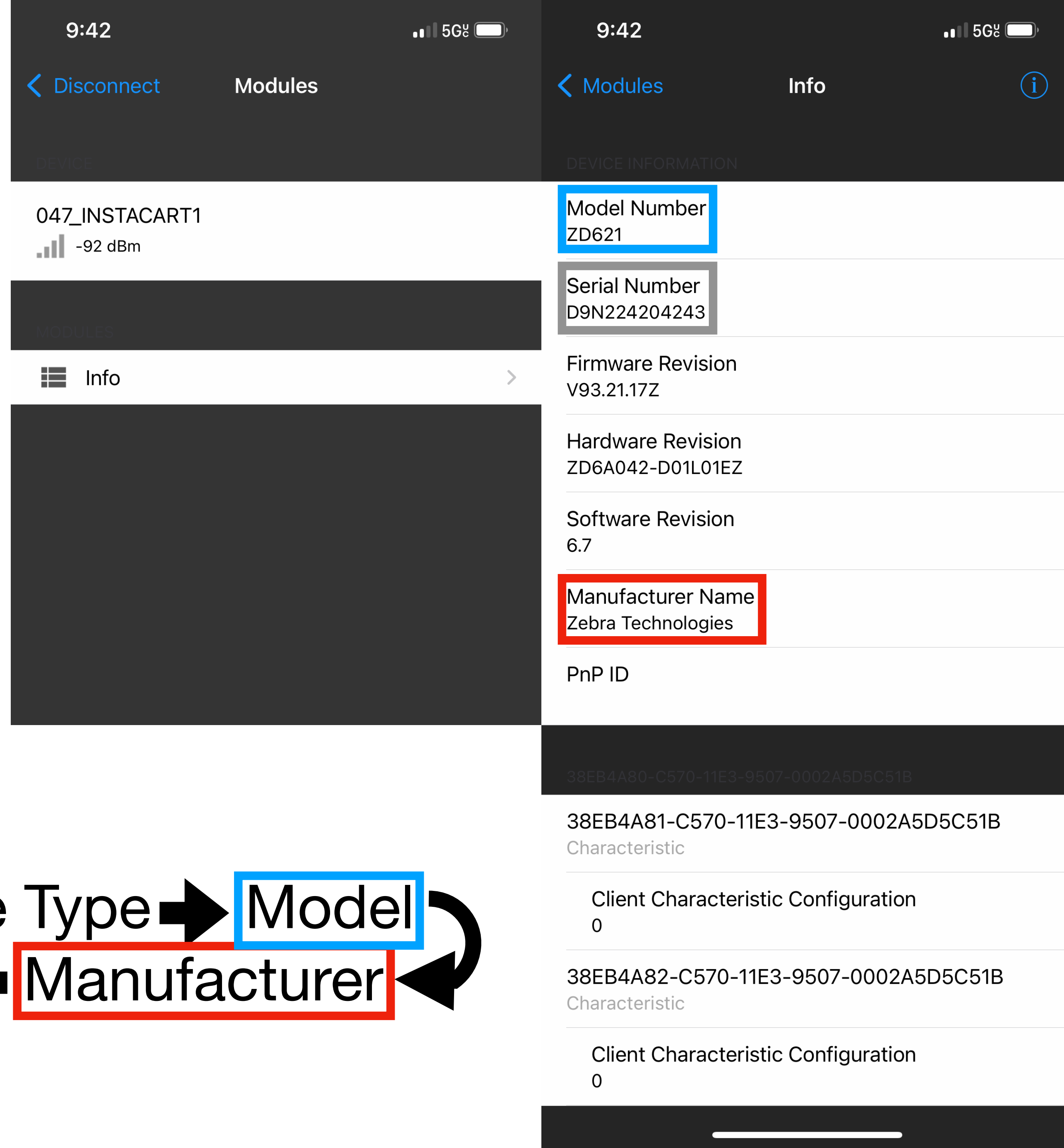



# GATT on Phones

- When you open a Bluetooth scanner app like LightBlue or BluefruitConnect on your phone, and they show you information, usually that is GATT information
- This is from BluefruitConnect

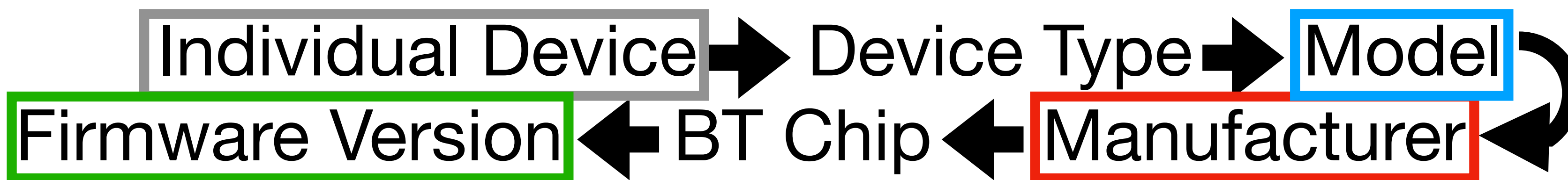
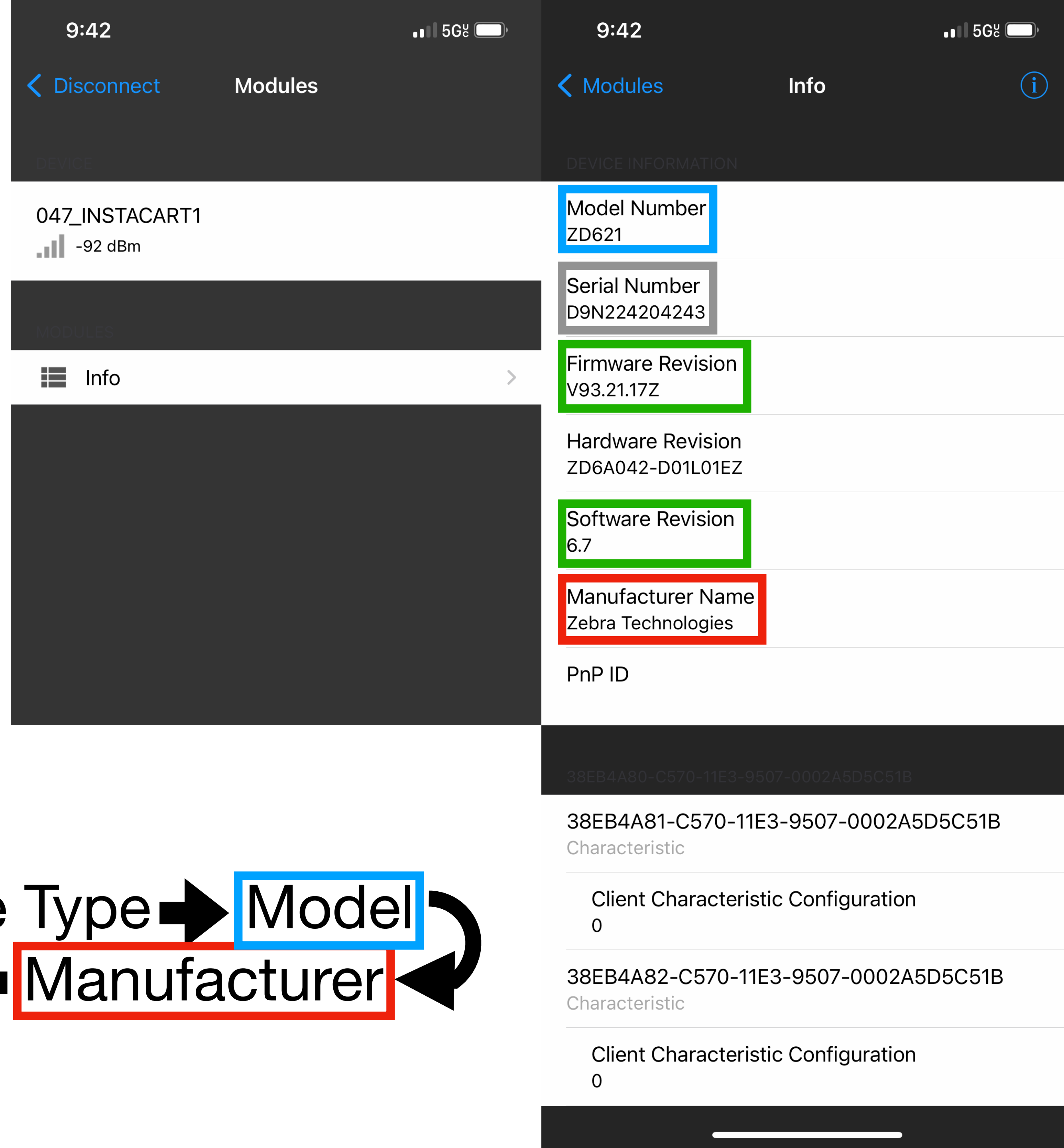



# GATT on Phones

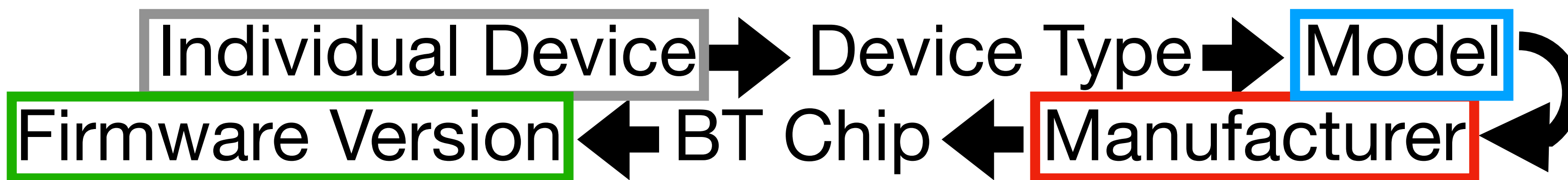
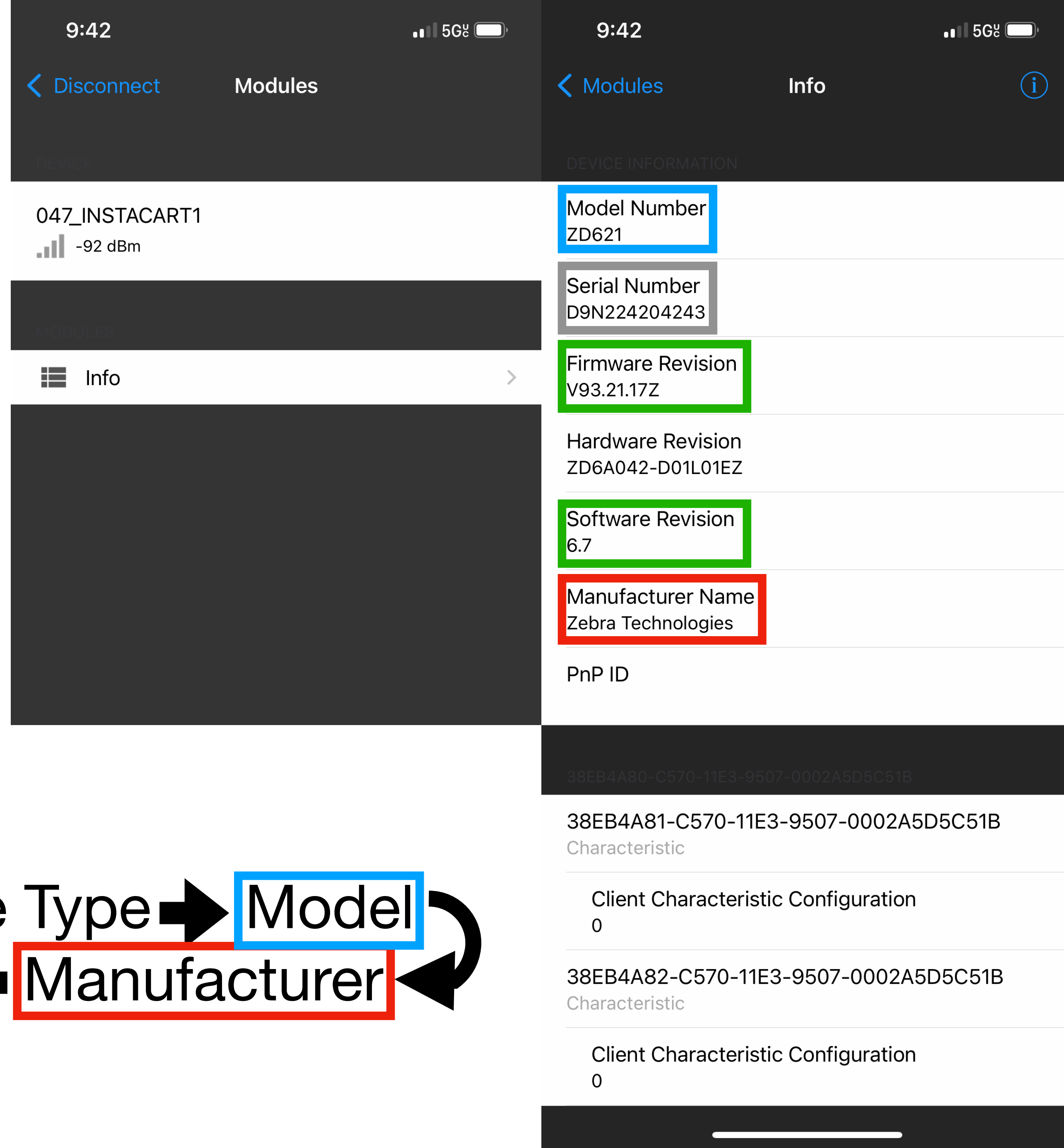

- When you open a Bluetooth scanner app like LightBlue or BluefruitConnect on your phone, and they show you information, usually that is GATT information
- This is from BluefruitConnect



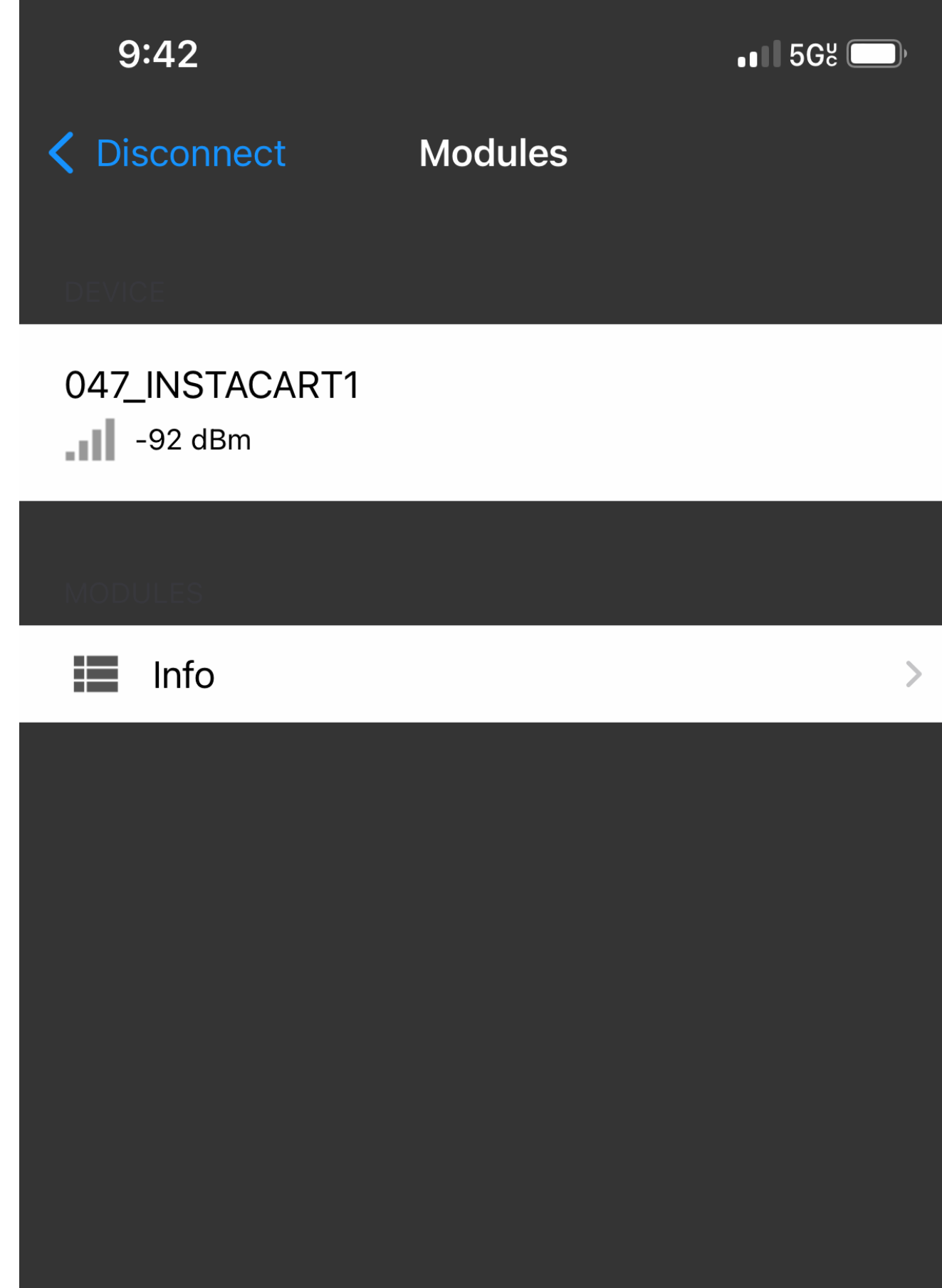

# GATT on Phones

- When you open a Bluetooth scanner app like LightBlue or BluefruitConnect on your phone, and they show you information, usually that is GATT information
- This is from BluefruitConnect

**ELEVATING A PROVEN WINNER**  
 Extending the G-Series Legacy

Zebra's GX Series printers are known for quality and premium performance. As you select your next printer, you can be confident that the next-generation ZD621 includes everything you loved in those legacy printers, and builds on this heritage to deliver best-in-class features for this new era of intelligence and forward adaptability.

**EXPECT THE BEST**  
 Premier Printing Performance

Rely on the ZD621 to help you power through – day after day. From outstanding print quality to portability for application flexibility to emerging technology to field-installable options, the ZD621 st

[Chat with us](#)

zebra.com — Private

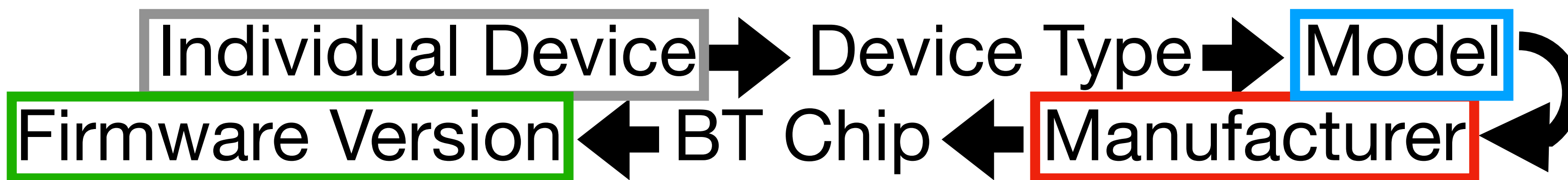



# GATT in General

- On the *OTHER* hand...we may instead get a whole bunch of *nothing useful* from GATT
- Devices may not respond to GATT requests, and when they do, we're in no way guaranteed to get "characteristics" which contain the kind of information we want
  - GATT inquiries can take a few seconds. For moving targets, there is a low probability of success to perform a full information collection without a strong transmitter and good antenna

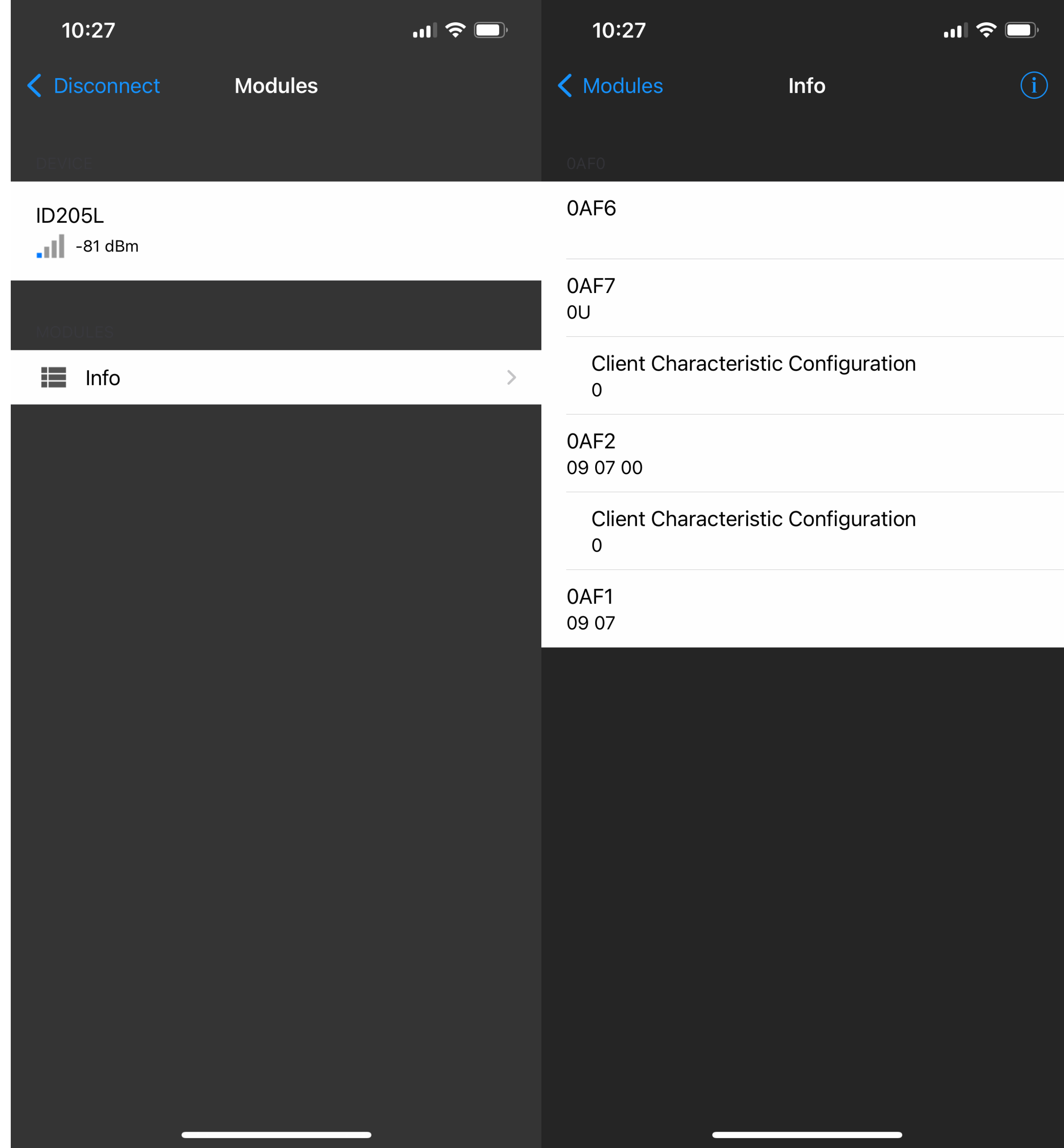



# GATT in General

- On the *OTHER* hand...we may instead get a whole bunch of *nothing useful* from GATT
- Devices may not respond to GATT requests, and when they do, we're in no way guaranteed to get "characteristics" which contain the kind of information we want
  - GATT inquiries can take a few seconds. For moving targets, there is a low probability of success to perform a full information collection without a strong transmitter and good antenna

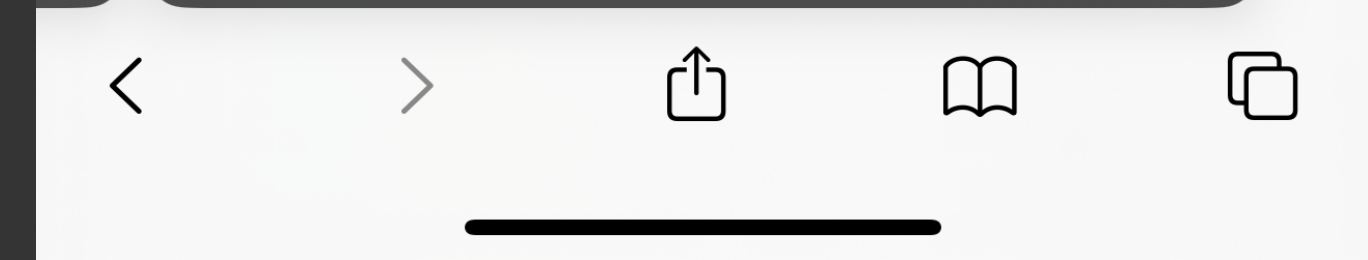
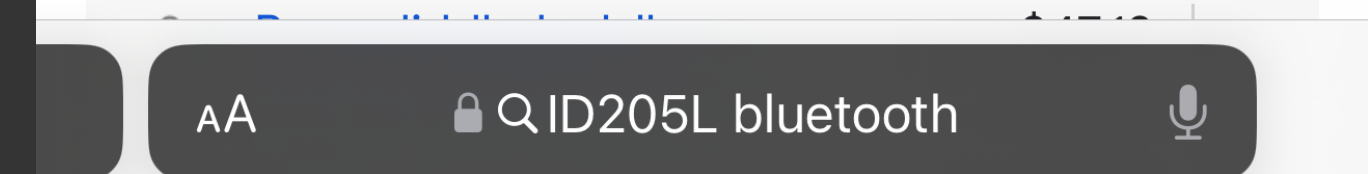
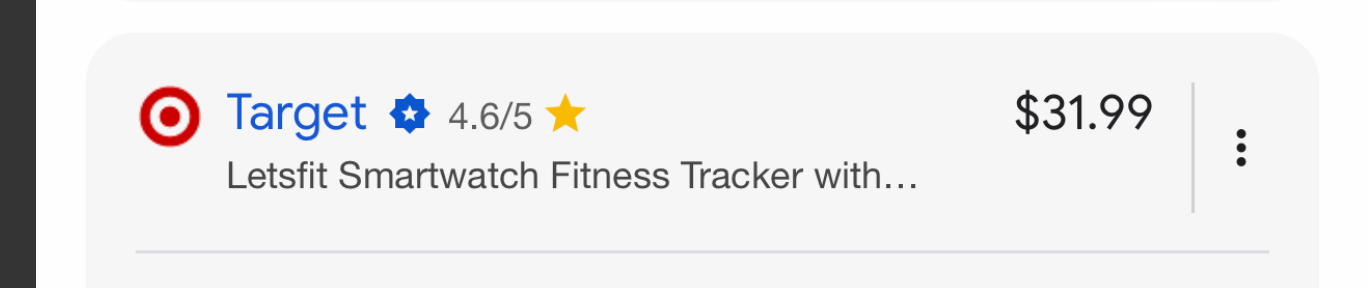
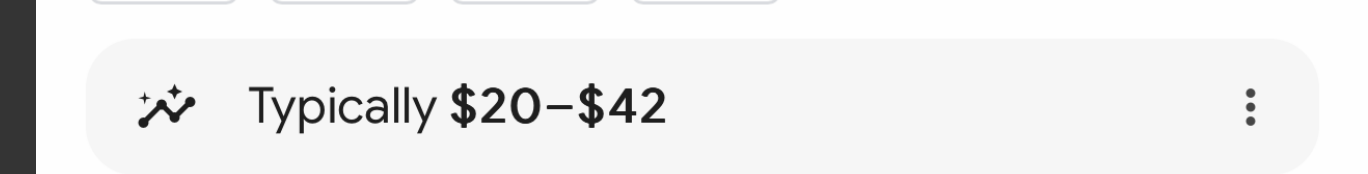
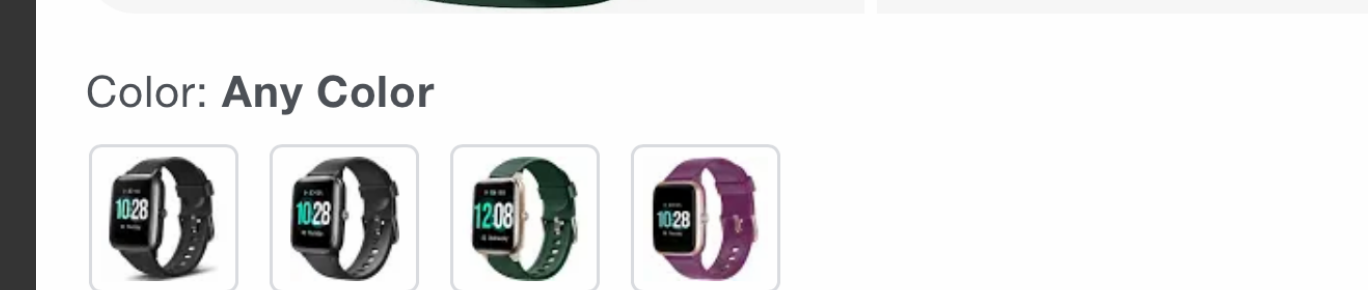
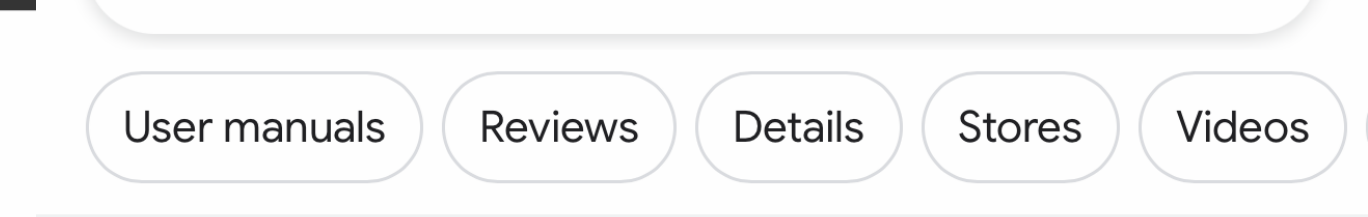
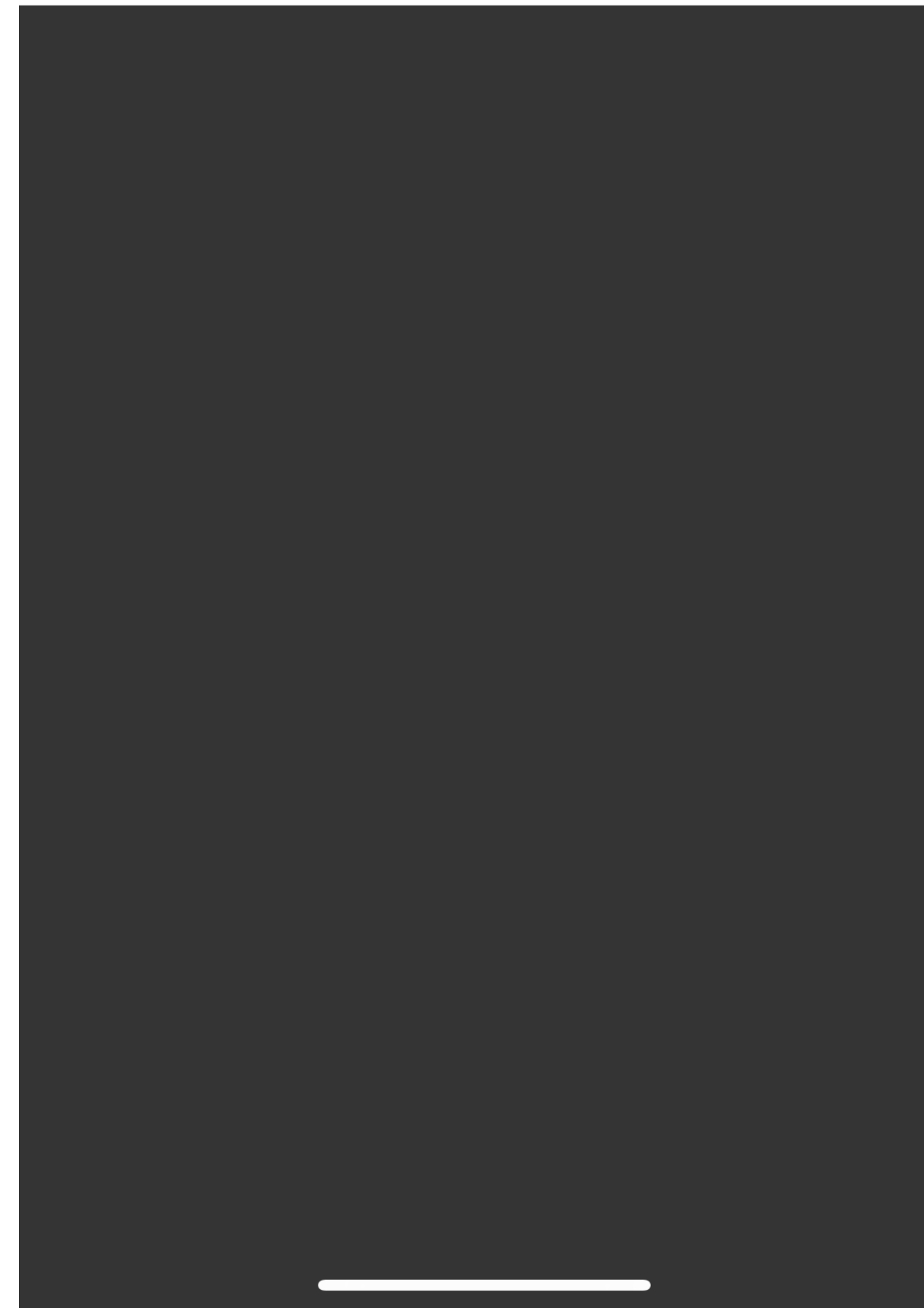



# Prior Work

## "Fingerprinting Bluetooth-Low-Energy Devices Based on the Generic Attribute Profile"

- [1] by Celosia & Cunche from 2019 connected 🏆 to BLE devices via GATT and just called *all the returned information* the fingerprint
- Noteworthy, in my mind, for the different threat model (user privacy), that called out basically everything *except* firmware revision string as interesting

We identified that information found in GATT profiles can be used to infer the following information: **device type, device model, device manufacturer** and **user's name**. All this information can threaten the privacy of the device owner.



# Prior Work

"Fingerprinting Bluetooth-Low-Energy De

You know what's really a threat to user privacy?  
Getting pwned over-the-air ;)



- [1] by Celosia & Cunche from 2019 connected 🏆 to BLE devices via GATT and just called *all the returned information* the fingerprint
- Noteworthy, in my mind, for the different threat model (user privacy), that called out basically everything *except* firmware revision string as interesting

We identified that information found in GATT profiles can be used to infer the following information: **device type**, **device model**, **device manufacturer** and **user's name**. All this information can threaten the privacy of the device owner.

**Table 4: Average time to collect a GATT profile among different devices.**

Device type	Device	Time (sec)
Lightbulb	Osram Smart+	6.531
Motion sensor	Eve Motion	6.468
Socket outlet	Eve Energy	5.919
Smartphone	Apple iPhone 8	4.354
Smartphone	Apple iPhone 6	4.259
Keyring	Nut	4.148
TV dongle	Google Chromecast	3.660
Fitness wristband	Fitbit Inspire	3.231
Presentation remote	Logitech Spotlight	2.860
Smartwatch	Apple Watch Series 3	2.853
Heart rate monitor	Polar H7	2.751
Fitness wristband	Fitbit Flex	2.552
Headset	Bose SoundLink Around-Ear II	2.181
Speaker	Divacore Ktulu2+	1.742
Keyring	Chipolo	1.426
	Average	3.662

**Table 4: Average time to collect a GATT profile among different devices.**

Device type	Device	Time (sec)
Lightbulb	Osram Smart+	6.531
Motion sensor	Eve Motion	6.468
Socket outlet	Eve Energy	5.919
Smartphone	Apple iPhone 8	4.354
Smartphone	Apple iPhone 6	4.259
Keyring	Nut	4.148
TV dongle	Google Chromecast	3.660
Fitness wristband	Fitbit Inspire	3.231
Presentation remote	Logitech Spotlight	2.860
Smartwatch	Apple Watch Series 3	2.853
Heart rate monitor	Polar H7	2.751
Fitness wristband	Fitbit Flex	2.552
	Sound-Ear II	2.181
		1.742
		1.426
		3.662

**I've seen things take up to 24 seconds to reply to GATT printing...**



**Table 4: Average time to collect a GATT profile among different devices.**

Device type	Device	Time (sec)
Lightbulb	Osram Smart+	6.531
Motion sensor	Eve Motion	6.468
Socket outlet	Eve Energy	5.919
Smartphone	Apple iPhone 8	4.354
Smartphone	Apple iPhone 6	4.259
Keyring	Nut	4.148
TV dongle	Google Chromecast	3.660
Fitness wristband	Fitbit Inspire	3.231
Presentation remote	Logitech Spotlight	2.860
Smartwatch	Apple Watch Series 3	2.853
Heart rate monitor	Polar H7	2.751
Fitness wristband	Fitbit Flex	2.552
	Sound-Ear II	2.181
		1.742
		1.426
		3.662

I've seen things take up to 24 seconds to reply to GATT printing...



	All	
	%	#
Device Name	99.49	13182
Appearance	99.48	13082
Service Changed	0.02	2
Manufacturer Name String	99.48	9177
Model Number String	99.36	9158
Battery Level	2.45	191
Current Time	0.41	31
Peripheral Preferred Connection Parameters	99.90	1051
Software Revision String	97.04	1017
Hardware Revision String	95.95	996
Serial Number String	97.12	979
Firmware Revision String	94.99	835



	All	
	%	#
Device Name	99.49	13182
Appearance	99.48	13082
Service Changed	0.02	2
Manufacturer Name String	99.48	9177
Model Number String	99.36	9158
Battery Level	2.45	191
Current Time	0.41	31
Peripheral Preferred Connection Parameters	99.90	1051
Software Revision String	97.04	1017
Hardware Revision String	95.95	996
Serial Number String	97.12	979
Firmware Revision String	94.99	835

At least 13182 devices reported a Name (and it was readable 99.49% of the time)



	All	
	%	#
Device Name	99.49	13182
Appearance	99.48	13082
Service Changed	0.02	2
Manufacturer Name String	99.48	9177
Model Number String	99.36	9158
Battery Level	2.45	191
Current Time	0.41	31
Peripheral Preferred Connection Parameters	99.90	1051
Software Revision String	97.04	1017
Hardware Revision String	95.95	996
Serial Number String	97.12	979
Firmware Revision String	94.99	835

At least 13182 devices reported a Name (and it was readable 99.49% of the time)

**Only 835 devices reported a Firmware Revision String!**  
(and it was readable 94.49% of the time)





	All	
	%	#
Device Name	99.49	13182
Appearance	99.48	13082
Service Changed	0.02	2
Manufacturer Name String	99.48	9177
Model Number String	99.36	9158
Battery Level	2.45	191
Current Time	0.41	31
Peripheral Preferred Connection Parameters	99.90	1051
Software Revision String	97.04	1017
Hardware Revision String	95.95	996
Serial Number String	97.12	979
Firmware Revision String	94.99	835

At least 13182 devices reported a Name (and it was readable 99.49% of the time)

**Only 835 devices reported a Firmware Revision String!**  
(and it was readable 94.49% of the time)

*Note: Their dataset is heavily skewed by containing at least 9924 iPhones, and iPhones don't report a Firmware Revision String*



	All	
	%	#
Device Name	99.49	13182
Appearance	99.48	13082
Service Changed	0.02	2
Manufacturer Name String	99.48	9177
Model Number String	99.36	9158
Battery Level	2.45	191
Current Time	0.41	31
Peripheral Preferred Connection Parameters	99.90	1051
Software Revision String	97.04	1017
Hardware Revision String	95.95	996
Serial Number String	97.12	979
Firmware Revision String	94.99	835

At least 13182 devices reported a Name (and it was readable 99.49% of the time)

**Only 835 devices reported a Firmware Revision String!**  
(and it was readable 94.49% of the time)

*Note: Their dataset is heavily skewed by containing at least 9924 iPhones, and iPhones don't report a Firmware Revision String*



	All	
	%	#
Device Name	99.49	13182
Appearance	99.48	13082
Service Changed	0.02	2
Manufacturer Name String	99.48	9177
Model Number String	99.36	9158
Battery Level	2.45	191
Current Time	0.41	31
Peripheral Preferred Connection Parameters	99.90	1051
Software Revision String	97.04	1017
Hardware Revision String	95.95	996
Serial Number String	97.12	979
Firmware Revision String	94.99	835

At least 13182 devices reported a Name (and it was readable 99.49% of the time)

**Only 835 devices reported a Firmware Revision String!**  
(and it was readable 94.49% of the time)

*Note: Their dataset is heavily skewed by containing at least 9924 iPhones, and iPhones don't report a Firmware Revision String*



# Prior Work

## "Fingerprinting Bluetooth-Low-Energy Devices Based on the Generic Attribute Profile"

- [1] by Zuo et al. from 2019 scanned 🚶 BLE devices via Generic Attribute Profile (GATT) and just called all the top level UUID128s the fingerprint
  - Here they were referring to more like a "device-*model*" fingerprint, not "individual-device" fingerprint
  - Most interestingly, they scraped a bunch of Android applications to attempt to extract GATT-related UUID128s via static analysis



# My GATTPrint-er

- The BlueZ (*deprecated*) "gatttool" seemed to already do a good job of collecting this information. But the output wasn't easily machine-parsable. So I modified the source to store info to a more easily machine-parsable log file
- Pro tip: If you try to use the higher-layer BT APIs (such as those available via most Python->BT libraries), you will not be able to collect this info without first pairing. But pairing isn't actually necessary for most characteristics of most devices!
- Some devices though may refuse read/write requests on access control grounds, due to lack of the encryption/authentication that comes as a result of pairing



# Vendor-specific 128-bit UUIDs

## 🍪 Silicon-specific examples: Texas Instruments

- f000ffc0-0451-4000-b000-000000000000 - **OTA Firmware update GATT Service**
- f000ffc1-0451-4000-b000-000000000000, f000ffc2-0451-4000-b000-000000000000, f000ffc3-0451-4000-b000-000000000000, f000ffc4-0451-4000-b000-000000000000 - Associated GATT Characteristics
- BleedingBit exploited an Aruba-customized TI OTA firmware update service (that just added some security-by-obscurity magic unlock code)



# Vendor-specific 128-bit UUIDs

## 🍪 Silicon-specific examples: Nordic

- 6e400001-b5a3-f393-e0a9-e50e24dcca9e - **UART** GATT Service (advertised in SCAN\_RSP as well as GATT)
  - 6e400002-b5a3-f393-e0a9-e50e24dcca9e - UART RX GATT Characteristic
  - 6e400003-b5a3-f393-e0a9-e50e24dcca9e - UART TX GATT Characteristic
- 00001530-1212-efde-1523-785feabcd123 - "**Legacy**" (Insecure) **Device Firmware Update (DFU)** GATT Service
  - 00001531-1212-efde-1523-785feabcd123, 00001532-1212-efde-1523-785feabcd123, 00001533-1212-efde-1523-785feabcd123 - Associated GATT Characteristics
- 0000fe59-0000-1000-8000-00805f9b34fb - **Secure Device Firmware Update (DFU)** GATT Service
  - 8EC90001-F315-4F60-9FB8-838830DAEA50, 8EC90002-F315-4F60-9FB8-838830DAEA50 - Associated GATT Characteristics

# Vendor-specific 128-bit UUIDs

🍪 Silicon-specific examples: Cambridge Silicon Radio (bought by Qualcomm)

- 00001100-d102-11e1-9b23-00025b00a5a5 - **GAIA (Over The Air update protocol) GATT service**
- 00001101-d102-11e1-9b23-00025b00a5a5, 00001102-d102-11e1-9b23-00025b00a5a5, 00001103-d102-11e1-9b23-00025b00a5a5 - Associated GATT characteristics





# Vendor-specific 128-bit UUIDs

## 🍪 Silicon-specific examples: Silicon Labs

- 331a36f5-2459-45ea-9d95-6142f0c4b307 - **BGX Xpress Streaming (arbitrary data) GATT Service**
- a9da6040-0823-4995-94ec-9ce41ca28833, a73e9a10-628f-4494-a099-12efaf72258f, 75a9f022-af03-4e41-b4bc-9de90a47d50b - Associated GATT characteristics



# Vendor-specific 128-bit UUIDs

## Module-specific examples: Laird

- 569a1101-b87f-490c-92cb-11ba5ea5167c - **Virtual Serial Port Service (GATT & ADV\_IND)**
  - 569a2000-b87f-490c-92cb-11ba5ea5167c - TX GATT Characteristic
  - 569a2001-b87f-490c-92cb-11ba5ea5167c - RX GATT Characteristic



# What I Want

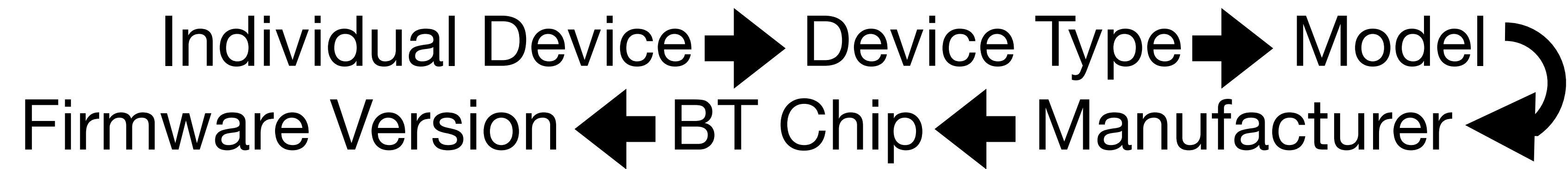



# What I Want

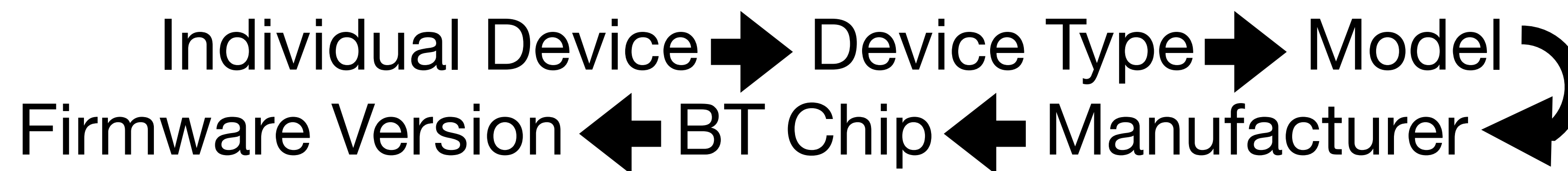

UUID128: 6e400001-b5a3-f393-e0a9-e50e24dcca9e



# What I Want

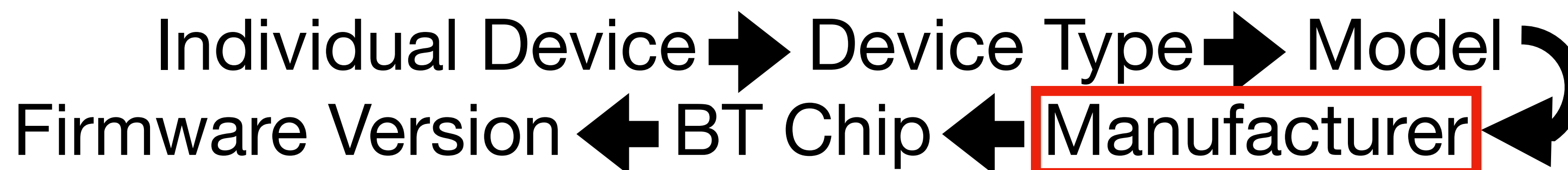

*Nordic*

UUID128Print  
DATABASE LOOKUP

UUID128: 6e400001-b5a3-f393-e0a9-e50e24dcca9e



# What I Want

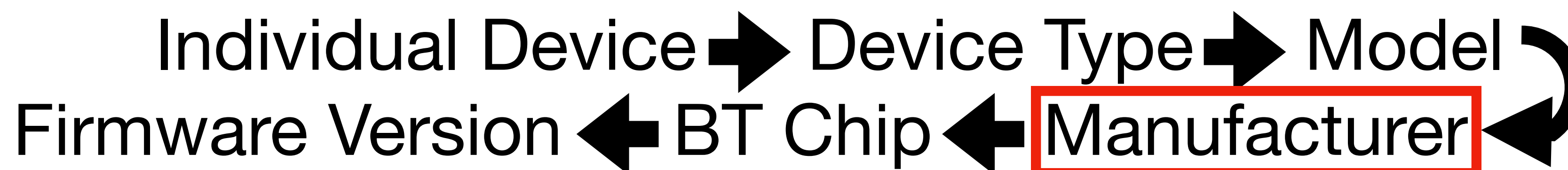

*Nordic*

UUID128Print  
DATABASE LOOKUP

UUID128: 6e400001-b5a3-f393-e0a9-e50e24dcca9e

## ASSUMPTION:

UUID128Prints can be reused *within* Manufacturers,  
but not reused *between* Manufacturers



# What I Want

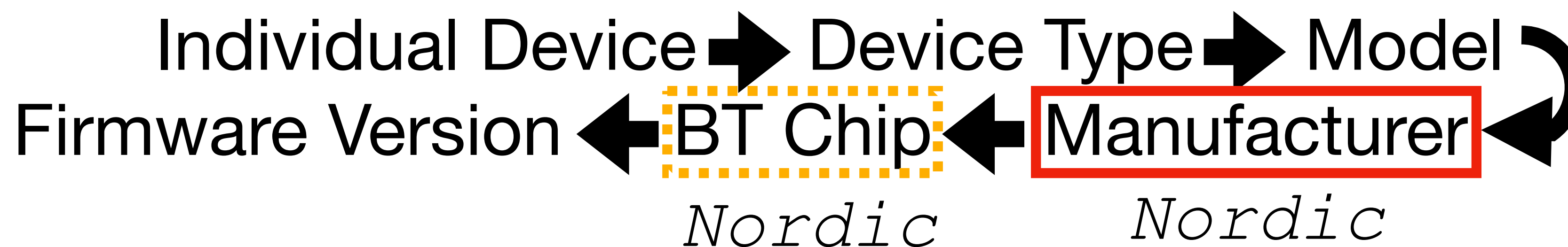

UUID128Print  
DATABASE LOOKUP

UUID128: 6e400001-b5a3-f393-e0a9-e50e24dcca9e

## ASSUMPTION:

UUID128Prints can be reused *within* Manufacturers,  
but not reused *between* Manufacturers



# Top 20 GATT Services in my data FWIW

2023-10-26

UUID128	Count	
00001800-0000-1000-8000-00805f9b34fb	21127	-> "Generic Access" (GAP)
00001801-0000-1000-8000-00805f9b34fb	20675	-> Generic Attribute (GATT)
0000180a-0000-1000-8000-00805f9b34fb	18044	-> Device Information
9fa480e0-4967-4542-9390-d343dc5d04ae	15738	-> Apple Nearby
d0611e78-bbb4-4591-a5f8-487910ae4366	15737	-> Apple Continuity
0000180f-0000-1000-8000-00805f9b34fb	11284	-> Battery
00001805-0000-1000-8000-00805f9b34fb	10641	-> Current Time
89d3502b-0f36-433a-8ef4-c502ad55f8dc	10636	-> Apple Media Service
7905f431-b5ce-4e99-a40f-4b1e122d00d0	10636	-> Apple Notification Center Service
0000febe-0000-1000-8000-00805f9b34fb	843	-> Bose
0000fe03-0000-1000-8000-00805f9b34fb	598	-> Amazon Alexa
0000fe2c-0000-1000-8000-00805f9b34fb	421	-> Google Fast Pair
9aa4730f-b25c-4cc3-b821-c931559fc196	359	-> Apple Watch? (my data seems to support)
eedd5e73-6aa8-4673-8219-398a489da87c	280	-> Samsung SmartTag Authentication Service
0000fd69-0000-1000-8000-00805f9b34fb	246	-> Samsung SmartTag Offline Finding Advertisement
0000feed-0000-1000-8000-00805f9b34fb	234	-> Tile
0000180d-0000-1000-8000-00805f9b34fb	222	-> Heart Rate
eed6d5cc-c3b2-4d7b-8c6b-7acbf7965bb6	204	-> Samsung Galaxy Watch (based on my data)
00001855-0000-1000-8000-00805f9b34fb	202	-> Telephony and Media Audio
0000184c-0000-1000-8000-00805f9b34fb	196	-> Generic Telephone Bearer





# Top 20 GATT Characteristics in my data FWIW

2023-10-26

char_UUID128	Count	
00002a00-0000-1000-8000-00805f9b34fb	19592	-> Device Name
00002a01-0000-1000-8000-00805f9b34fb	19205	-> Appearance
00002a05-0000-1000-8000-00805f9b34fb	18443	-> Service Changed
00002a29-0000-1000-8000-00805f9b34fb	16776	-> Manufacturer Name String
00002a24-0000-1000-8000-00805f9b34fb	16650	-> Model Number String
af0badb1-5b99-43cd-917a-a77bc549e3cc	15194	-> Apple Nearby Characteristic
8667556c-9a37-4c91-84ed-54ee27d90049	15193	-> Apple Continuity Characteristic
00002a19-0000-1000-8000-00805f9b34fb	10632	-> Battery Level
00002a2b-0000-1000-8000-00805f9b34fb	10245	-> Current Time
9fbf120d-6301-42d9-8c58-25e699a21dbd	10194	-> Apple Notification Center Notification Source
69d1d8f3-45e1-49a8-9821-9bbdfdaad9d9	10194	-> Apple Notification Center Control Point
22eac6e9-24d6-4bb5-be44-b36ace7c7bfb	10192	-> Apple Notification Center Data Source
9b3c81d8-57b1-4a8a-b8df-0e56f7ca51c2	10185	-> Apple Media Center Remote Command
2f7cabce-808d-411f-9a0c-bb92ba96c102	10183	-> Apple Media Center Entity Update
c6b2f38c-23ab-46d8-a6ab-a3a870bbd5d7	10183	-> Apple Media Center Entity Attribute
00002a0f-0000-1000-8000-00805f9b34fb	10176	-> Local Time Information
00002a26-0000-1000-8000-00805f9b34fb	1682	-> Firmware Revision String
00002aa6-0000-1000-8000-00805f9b34fb	1655	-> Central Address Resolution
00002a04-0000-1000-8000-00805f9b34fb	1644	-> Peripheral Preferred Connection Parameters
00002a28-0000-1000-8000-00805f9b34fb	1563	-> Software Revision String

# Putting It All *Toothgether* 🤪



# Putting It All *Toothgether* 🤪

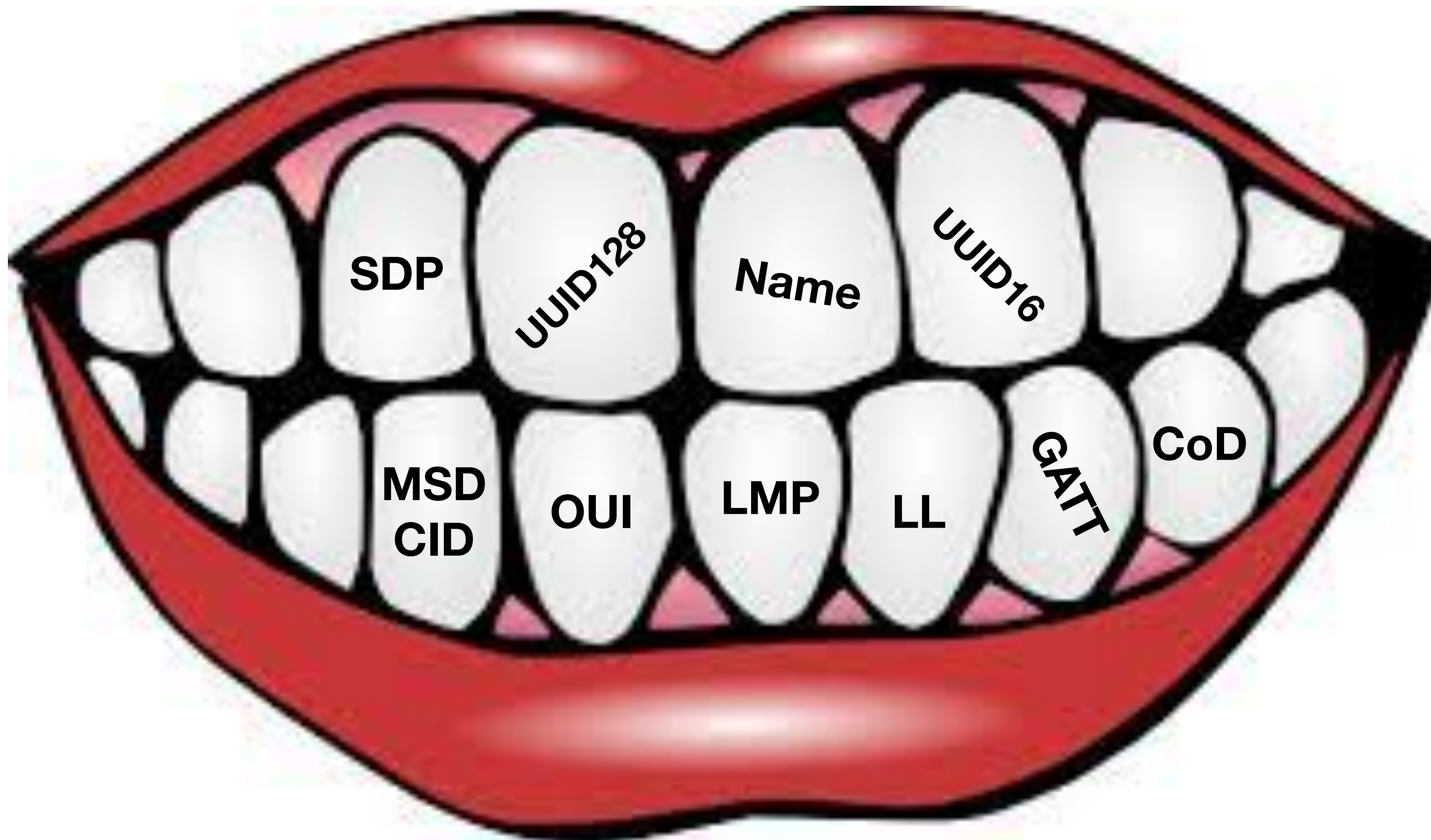



**Reminder, even if wireless links weren't *lossy*, you're not generally going to have all the data for every device**

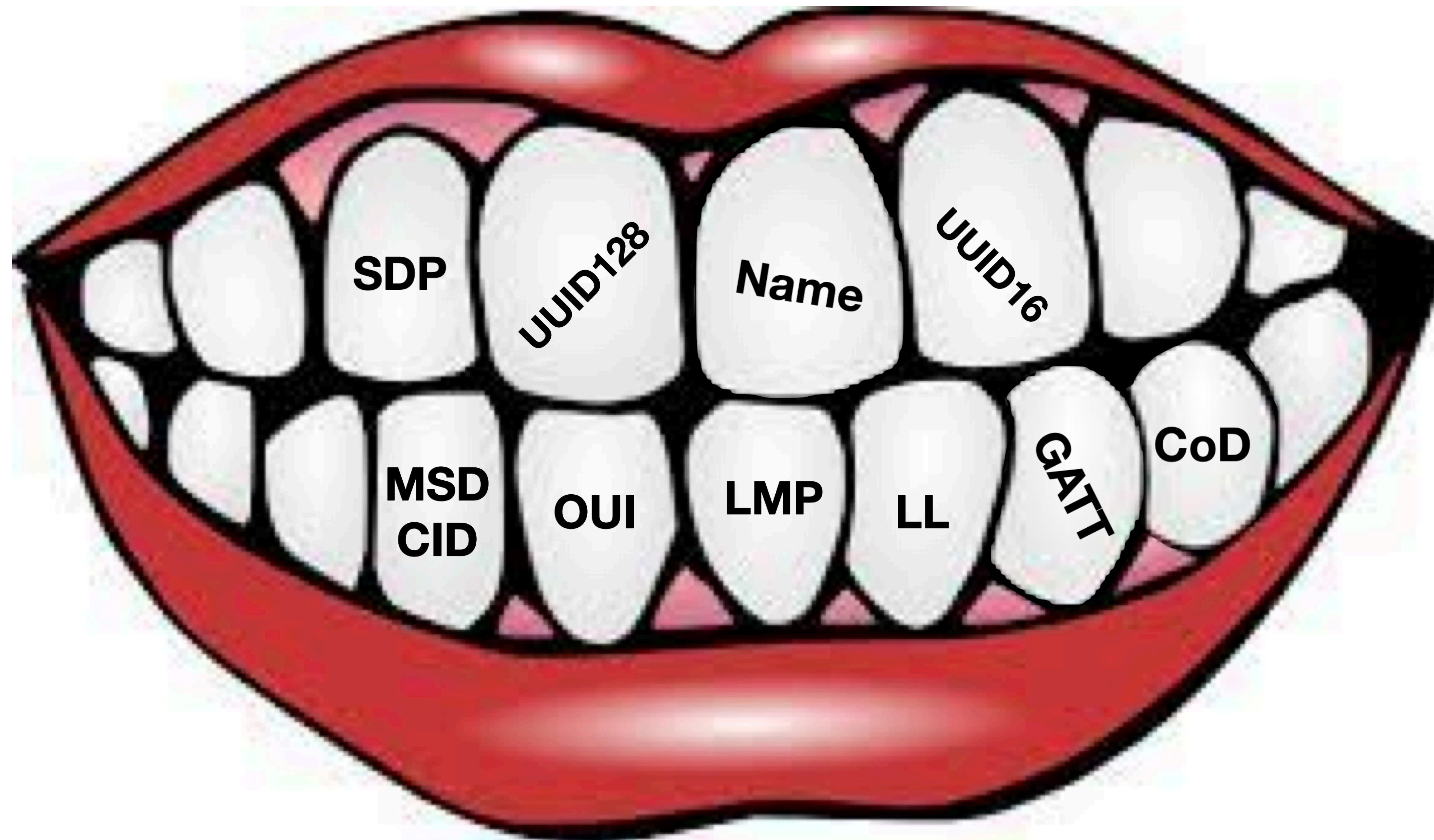



**Reminder, even if wireless links weren't *lossy*, you're not generally going to have all the data for every device**

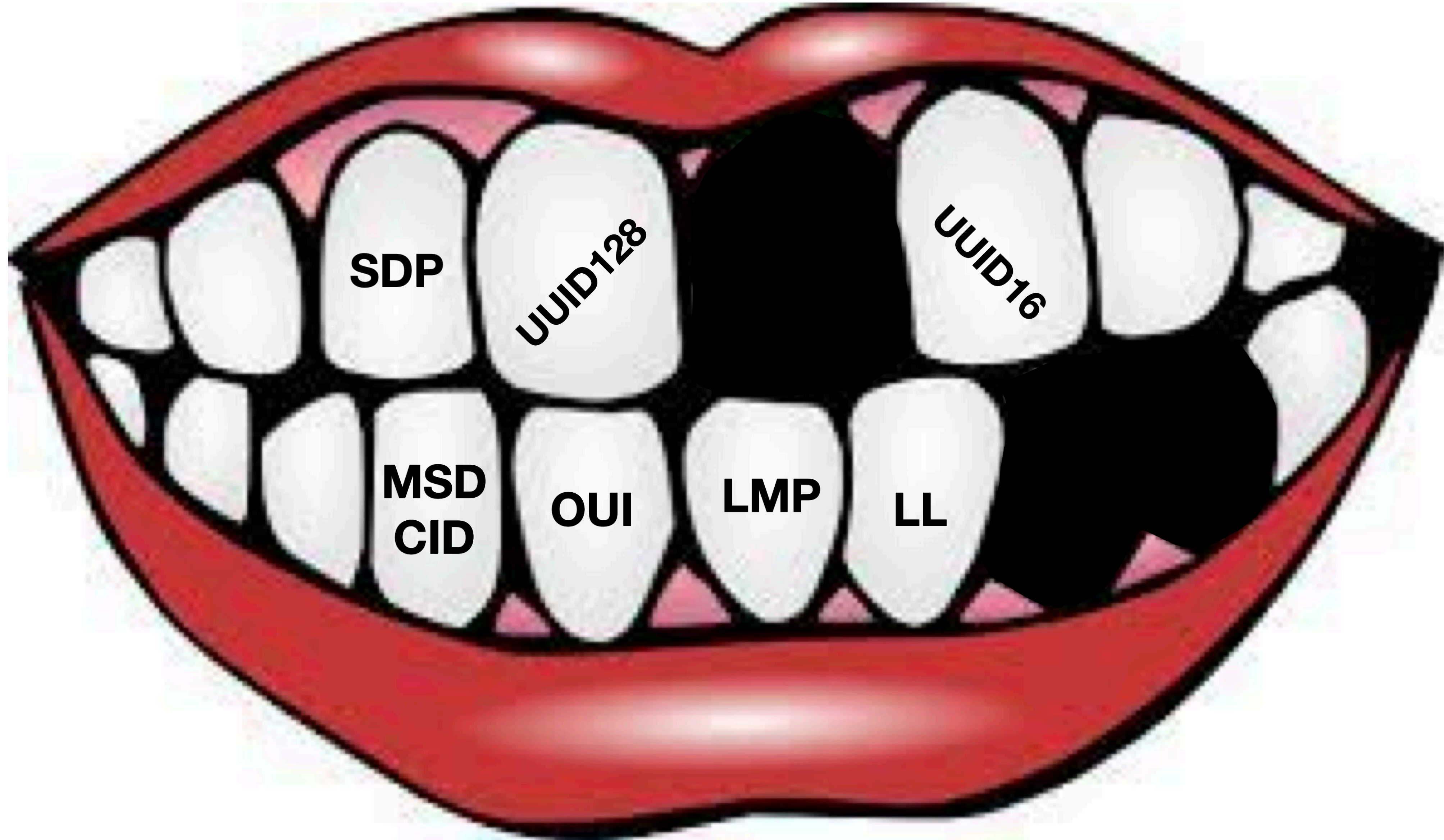

# Blue2thprinting

<https://github.com/darkmentorllc/Blue2thprinting>

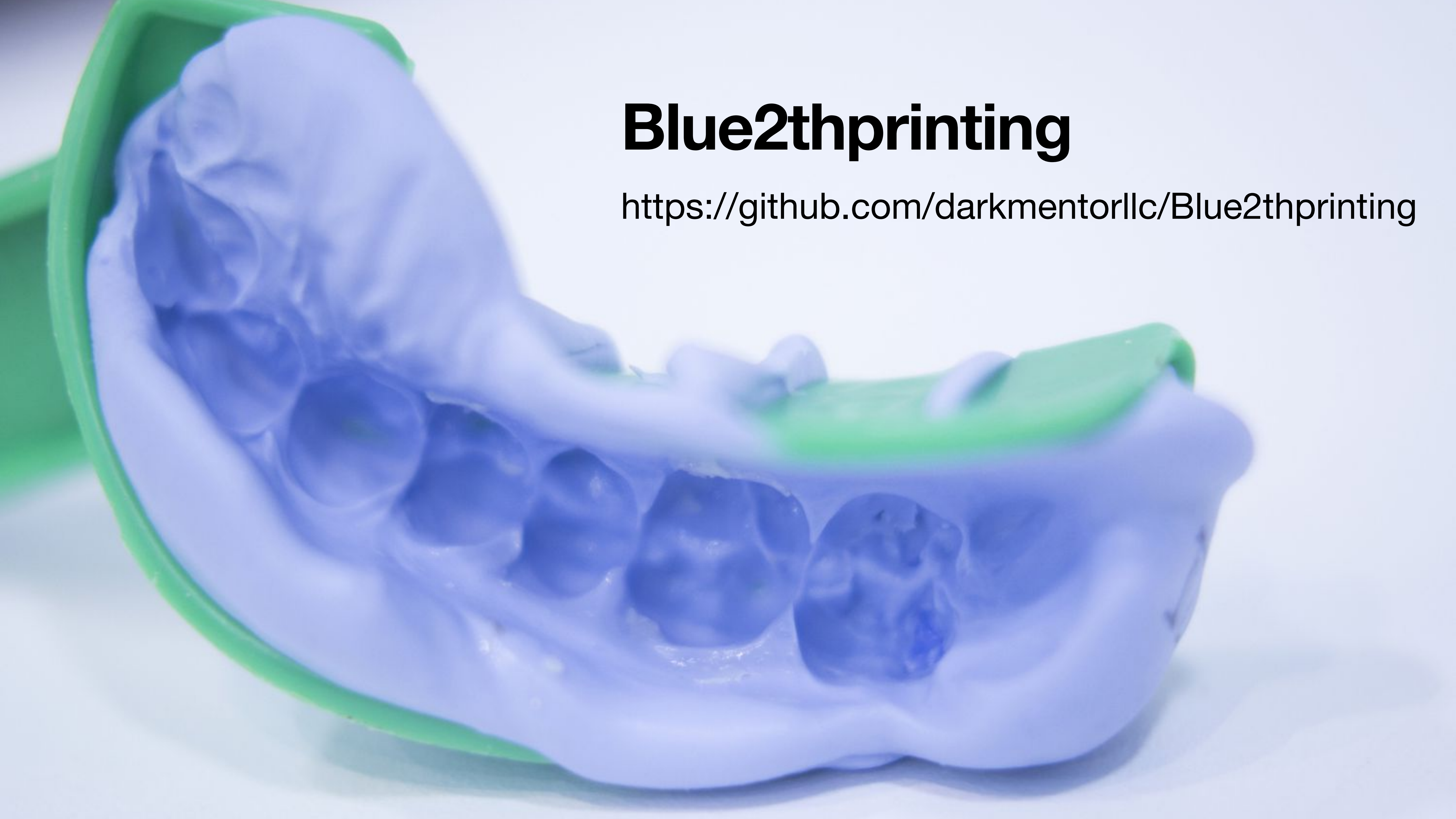

# Call To Action!



**JOIN ME! AND TOGETHER  
WE CAN RULE THE  
BLUETOOTH GALAXY!**

# Conclusion

- Bluetooth *vulnerability assessment* **is not yet a thing you can really do!**
- This is an active research topic I'm working on, but it needs more researchers working on it (because this is only 25% of my time ;))
  - "I'm puttin' together a (Blue)crew..."
- The starting point, as always, is to read related work
- I've organized the related work into a TiddlyWiki that I will continue to update over the coming years, and which others can contribute to via github PRs
  - <https://darkmentor.com/bt.html>





# Fin

# OSTA2

## OSTA2.FYI

- BT research is cool
- But *OpenSecurityTraining2* (<https://ost2.fyi> , @OpenSecTraining) is cooler!
  - We'll have BT classes eventually, but in the meantime there's so much other stuff to learn! Reverse Engineering, Vulnerabilities, Firmware, System Architecture!
- You should take a class, or *teach* a class!



# Backup



# Ongoing work

- How should I structure the 2thprints data?!
- What % of devices respond to GATT/SDP/LMP2th/LL2th/etc requests?
  - Working with a student on a research project to investigate more rigorously
- What other packet types (teef!) can we add to improve the 2thprint? (e.g. L2CAP? RFCOMM?)
- Can we do the work they didn't do in [1] to *automatically* generate minimal chip-model-differentiation packet sequences from existing learned state machines?



BTW

Did I mention the  
Bluetooth *ecosystem* is  
**ARCHITECTURALLY**  
**UNSECURABLE**



# UEFI Vulnerability Proliferation

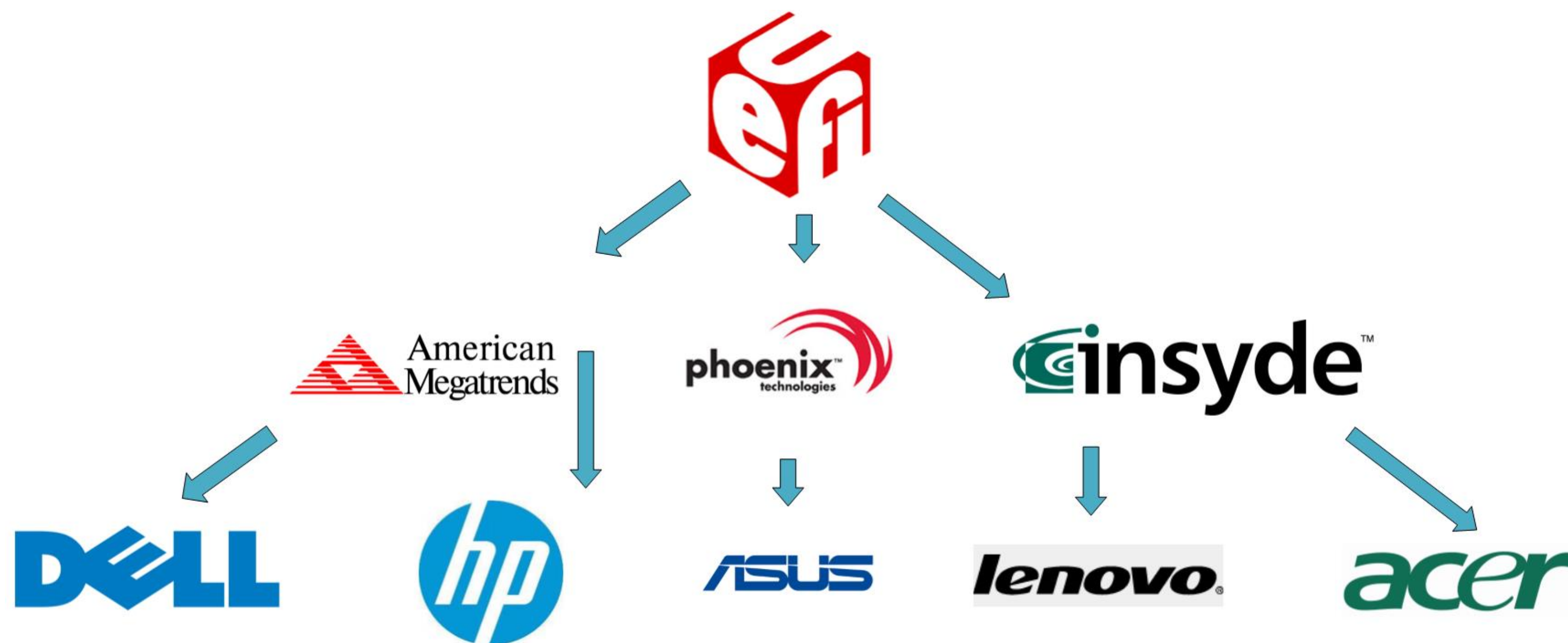

- If an attacker finds a vulnerability in the UEFI "reference implementation," its proliferation across IBVs and OEMs would potentially be wide spread.
  - More on how this theory works "in practice" later...



# UEFI Vulnerability Proliferation

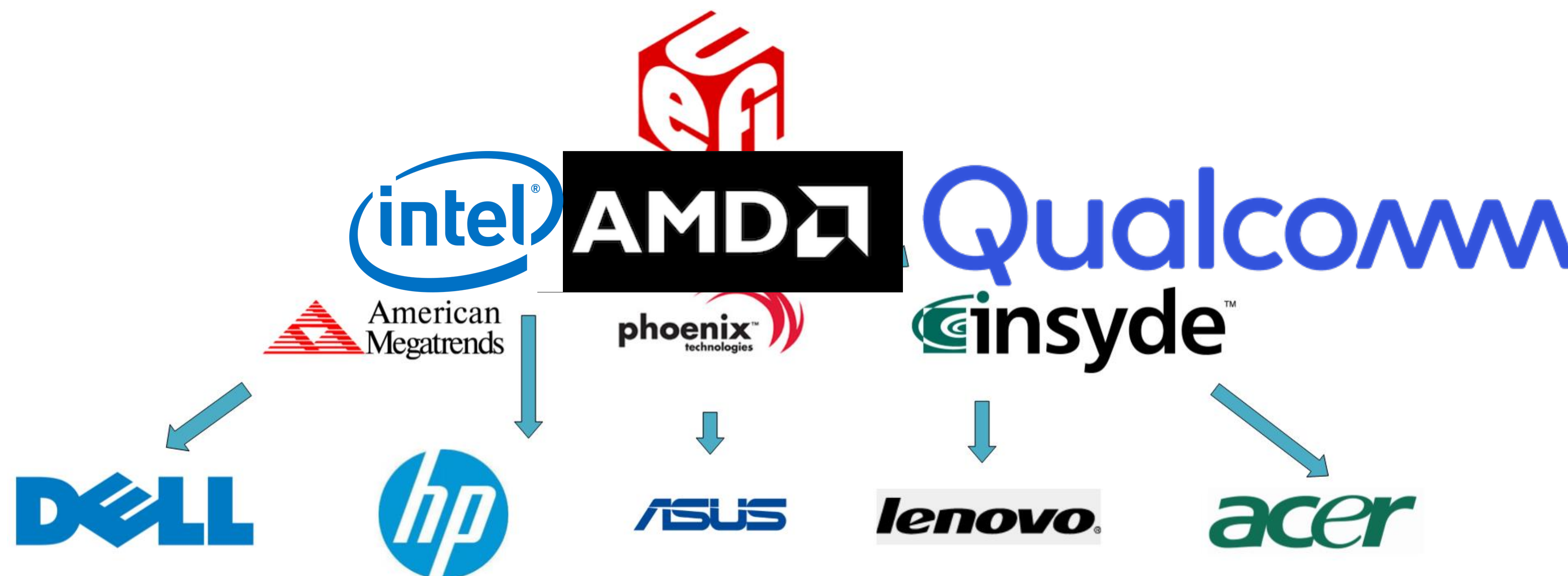

- If an attacker finds a vulnerability in the UEFI "reference implementation," its proliferation across IBVs and OEMs would potentially be wide spread.
  - More on how this theory works "in practice" later...



# UEFI Vulnerability Proliferation

# SIG

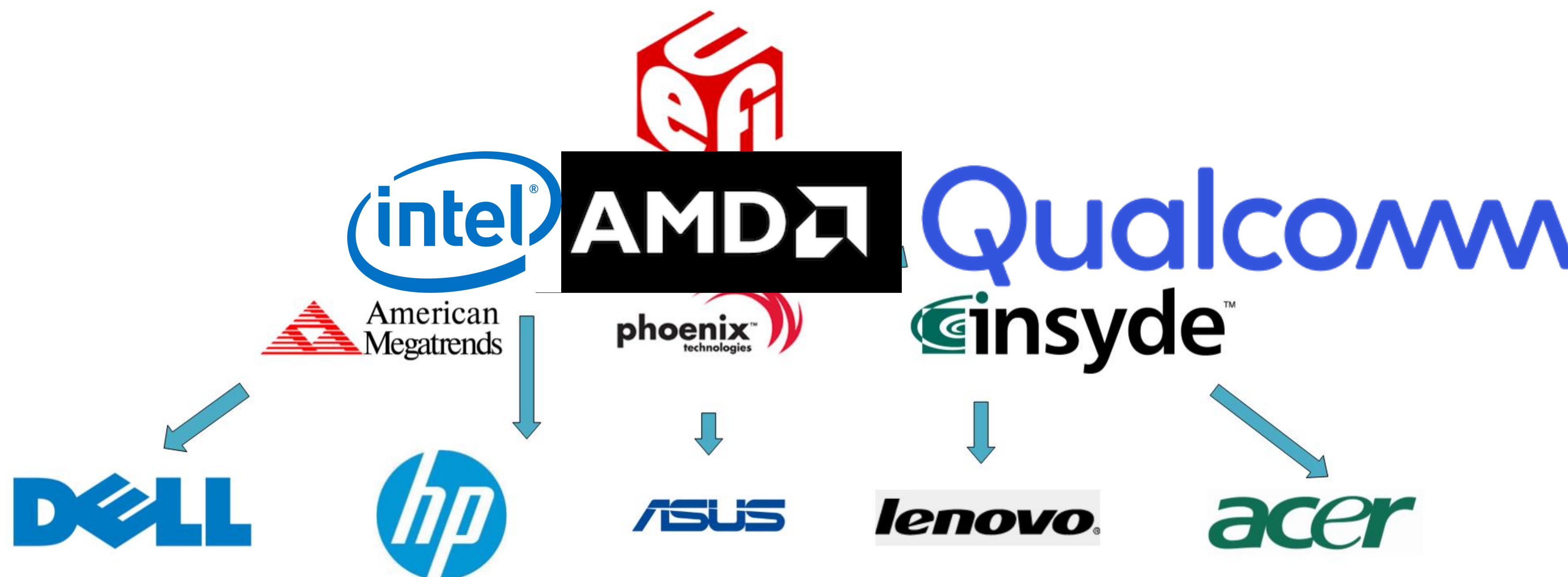

- If an attacker finds a vulnerability in the UEFI "reference implementation," its proliferation across IBVs and OEMs would potentially be wide spread.
  - More on how this theory works "in practice" later...



# UEFI Vulnerability Proliferation

SIG  
Silicon

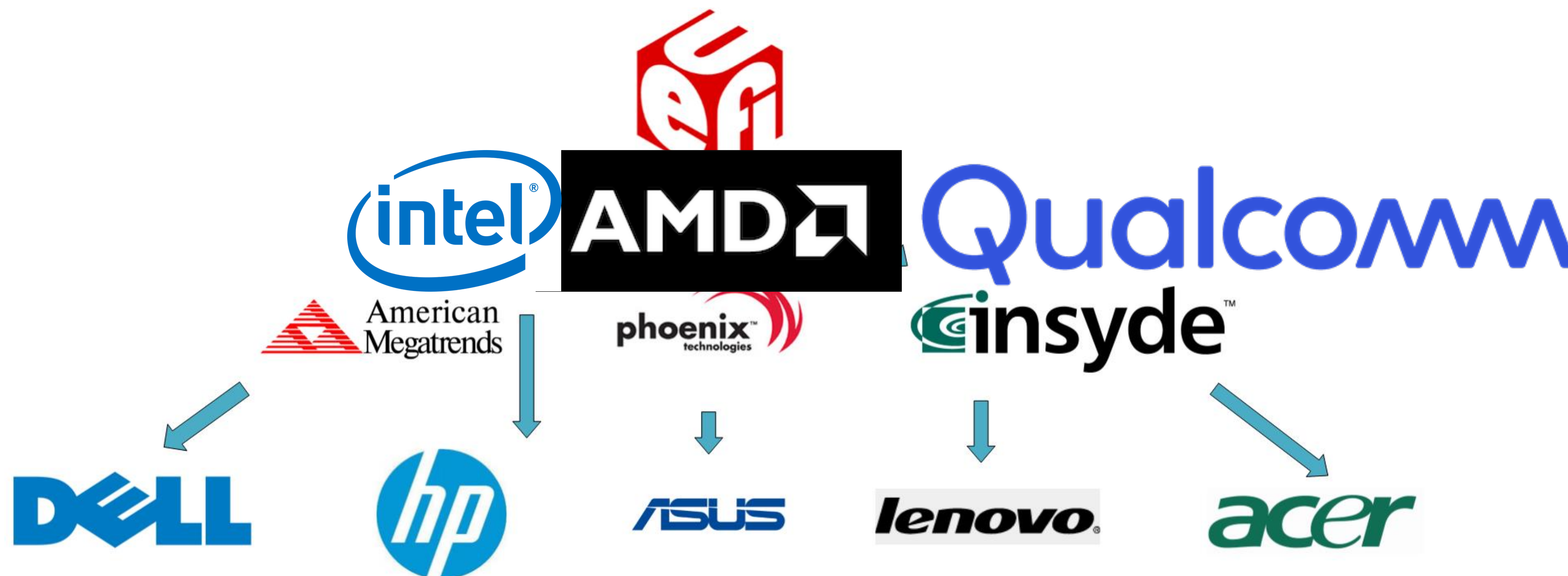

- If an attacker finds a vulnerability in the UEFI "reference implementation," its proliferation across IBVs and OEMs would potentially be wide spread.
  - More on how this theory works "in practice" later...





# UEFI Vulnerability Proliferation

SIG  
Silicon  
Intermediaries

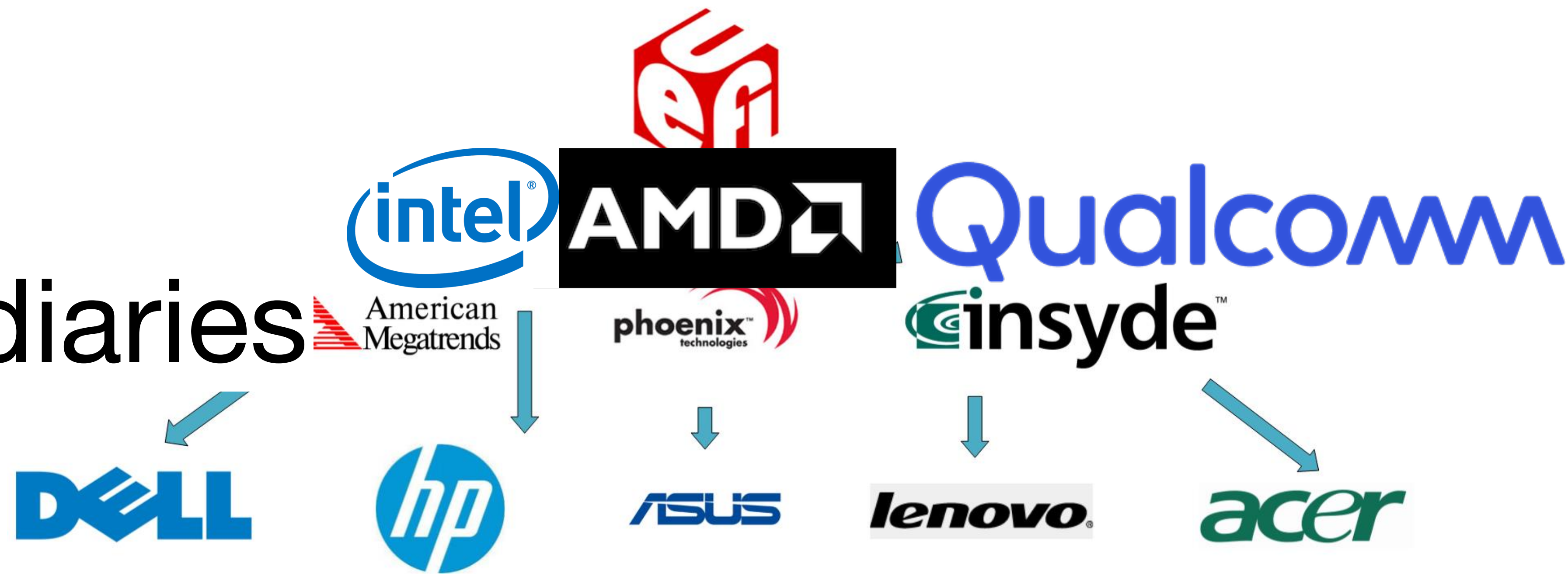

- If an attacker finds a vulnerability in the UEFI "reference implementation," its proliferation across IBVs and OEMs would potentially be wide spread.
  - More on how this theory works "in practice" later...



# UEFI Vulnerability Proliferation

SIG  
Silicon  
Intermediaries  
Device  
Makers

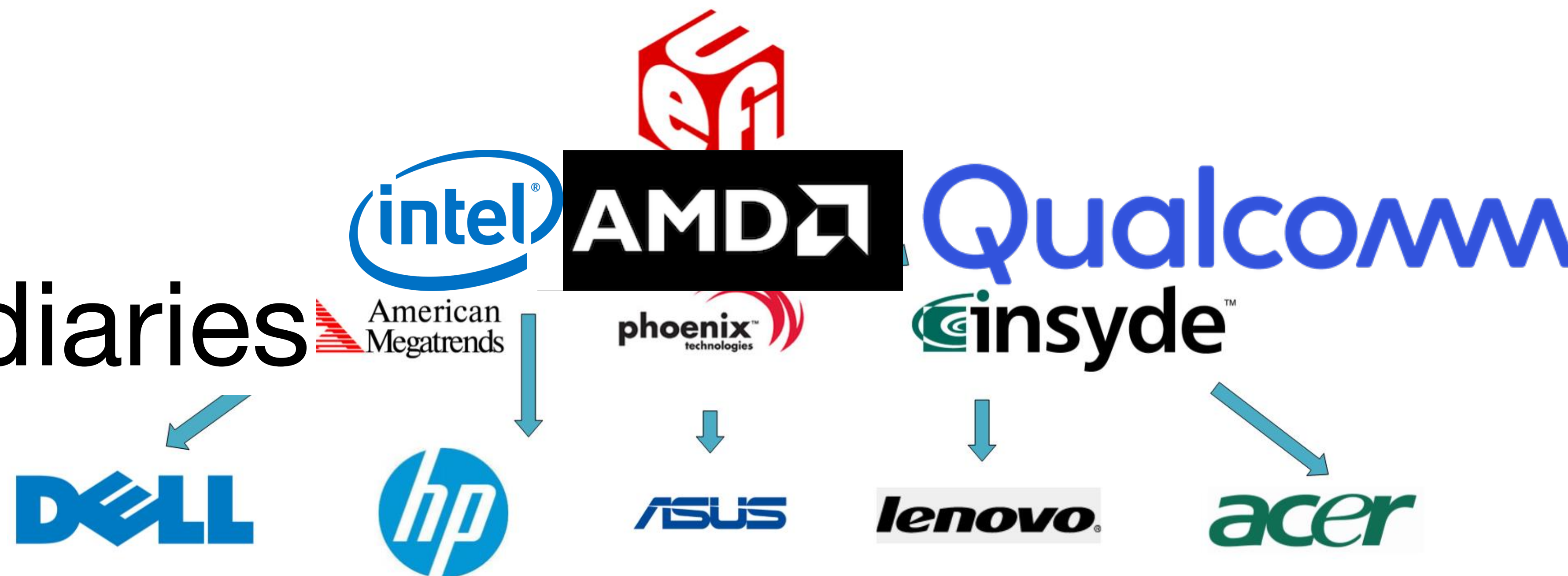

- If an attacker finds a vulnerability in the UEFI "reference implementation," its proliferation across IBVs and OEMs would potentially be wide spread.
  - More on how this theory works "in practice" later...



SIG



OST2  
FYI

# SIG

OST2  
.FYI



## Silicon Vendors (>20)

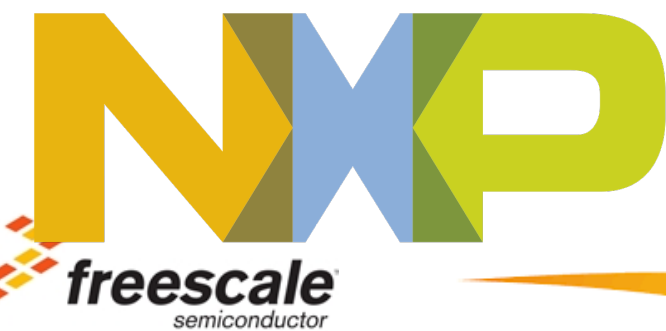
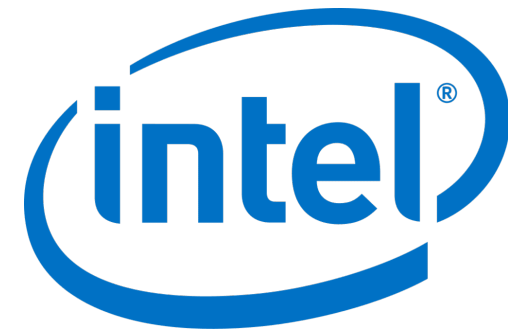
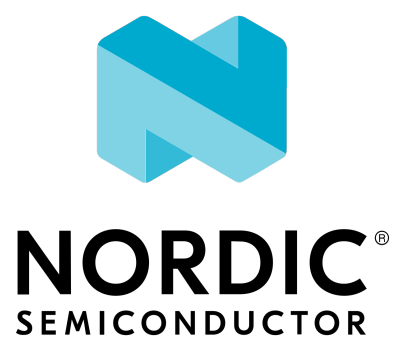
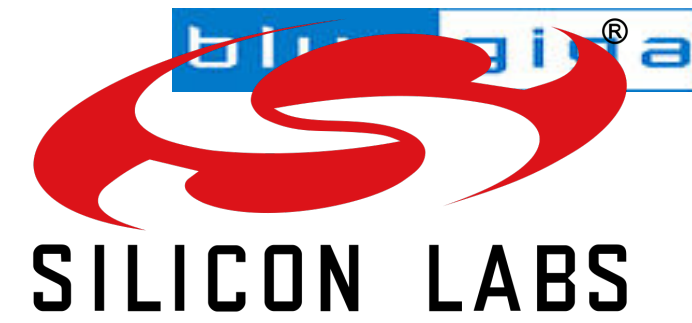

Telink



MICROCHIP



MARVELL™



# SIG

OST2  
.FYI



## Silicon Vendors (>20)

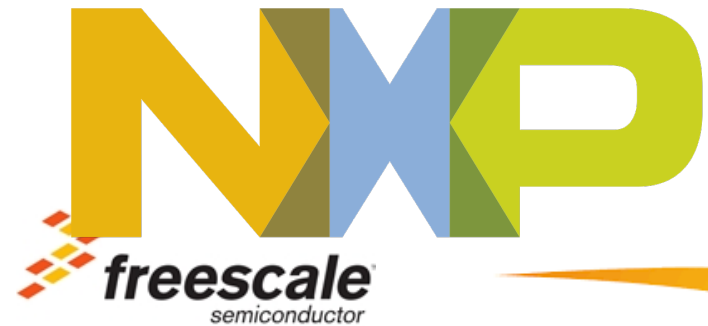
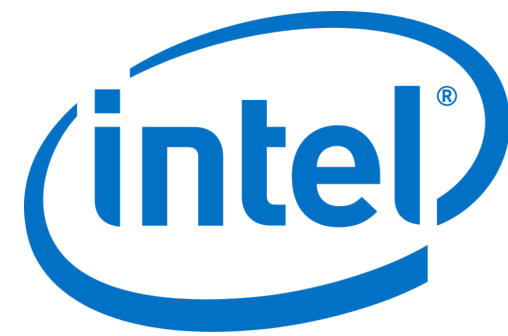
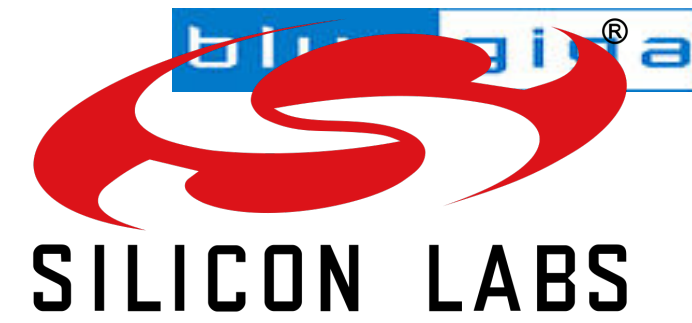

# SIG

OST2  
.FYI



## Silicon Vendors (>20)

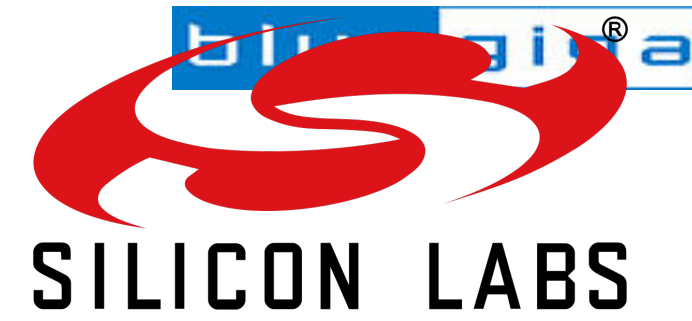

# Silicon

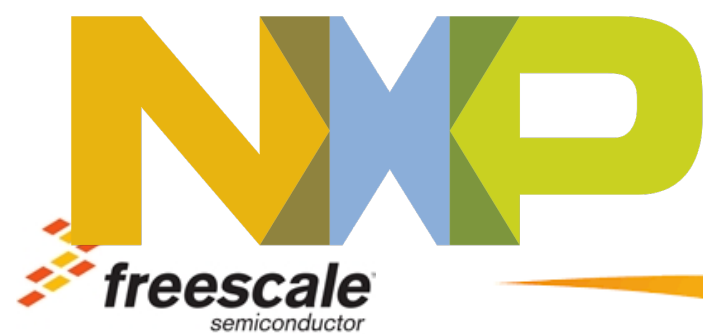
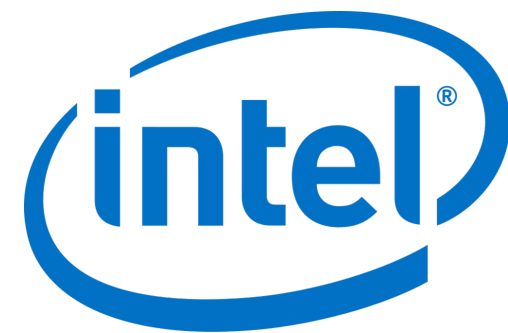

Telink



MICROCHIP



MARVELL™



## Module-Makers (IDEK how many)



晶讯  
JINGXUN



Rayson



# SIG

OST2  
.FYI



## Silicon Vendors (>20)

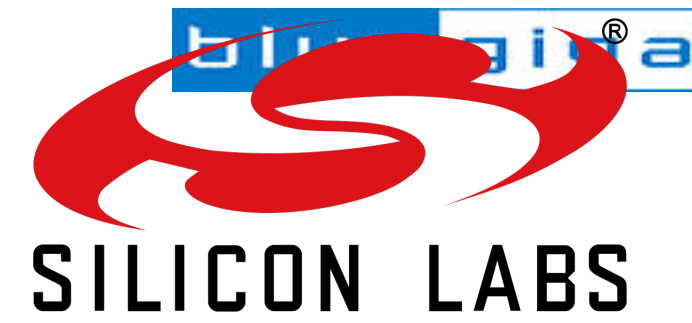

# Silicon

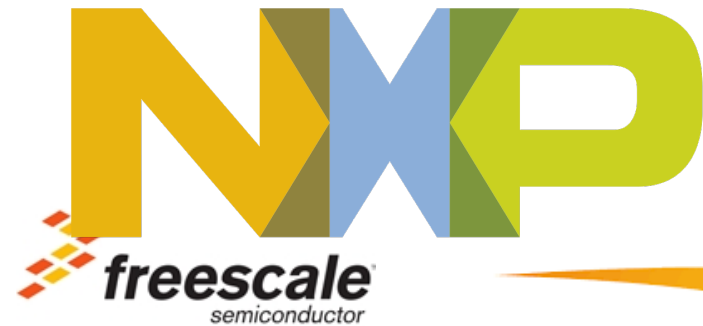
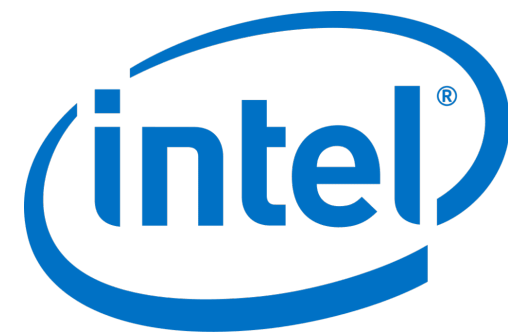

Telink



MICROCHIP



MARVELL



## Module-Makers (IDEK how many)

# Intermediaries



晶讯  
JINGXUN



Rayson





# SIG

OST2  
.FYI



## Silicon Vendors (>20)

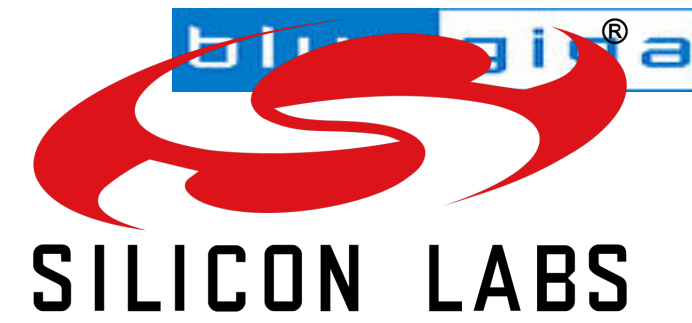

# Silicon

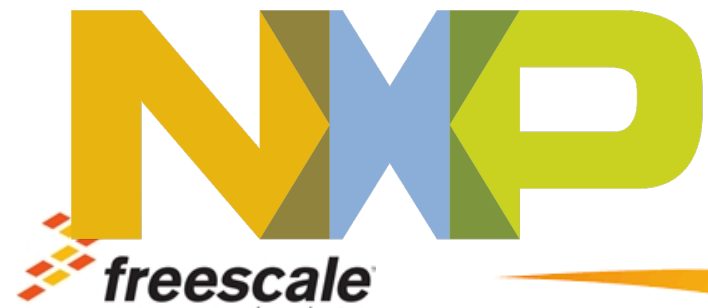
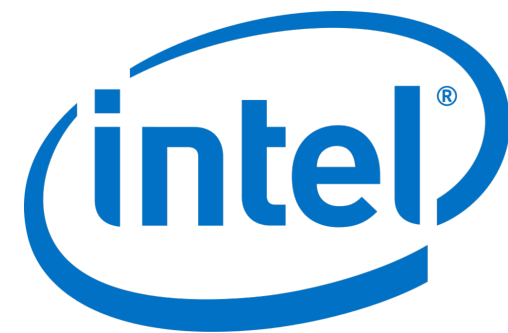

Telink



MICROCHIP



MARVELL



## Module-Makers (IDEK how many)

# Intermediaries



晶讯  
JINGXUN



Rayson



## Product-Makers

3330 registered with Bluetooth SIG as of the time of writing!

# SIG

OST2  
.FYI



## Silicon Vendors (>20)

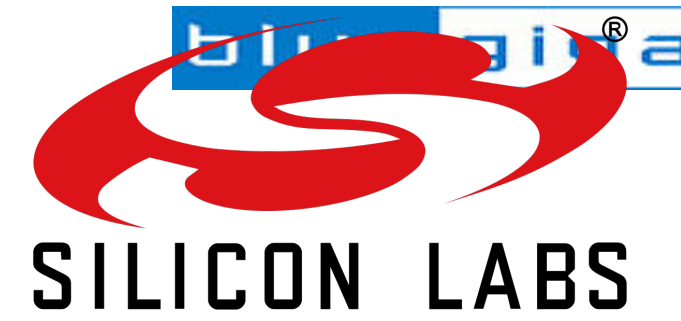

# Silicon

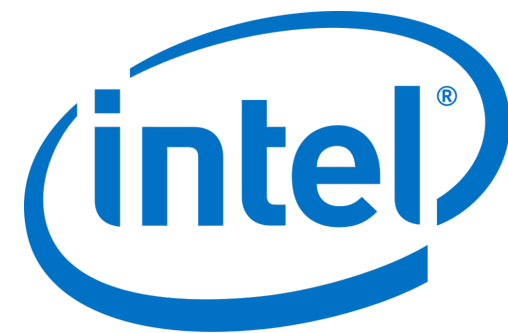

Telink



MICROCHIP



MARVELL



## Module-Makers (IDEK how many)

# Intermediaries



晶讯  
JINGXUN



Rayson



# Device

## Product-Makers



Makers 3330 registered with Bluetooth SIG as of the time of writing!

# SIG

OST2  
.FYI



## Silicon Vendors (>20)

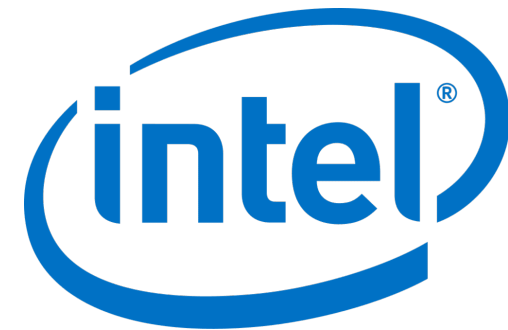
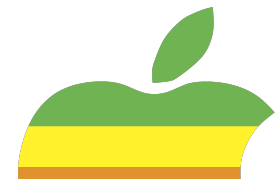
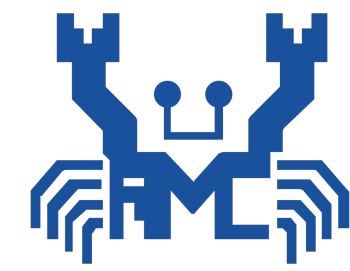
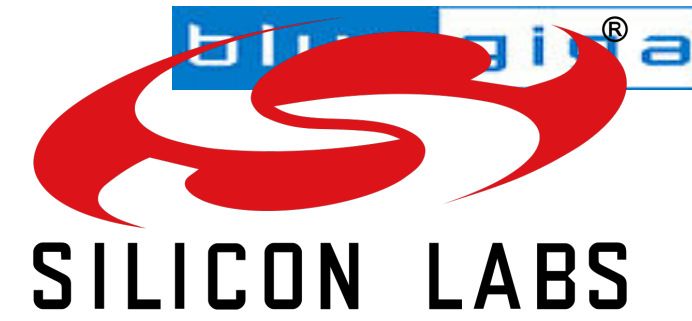
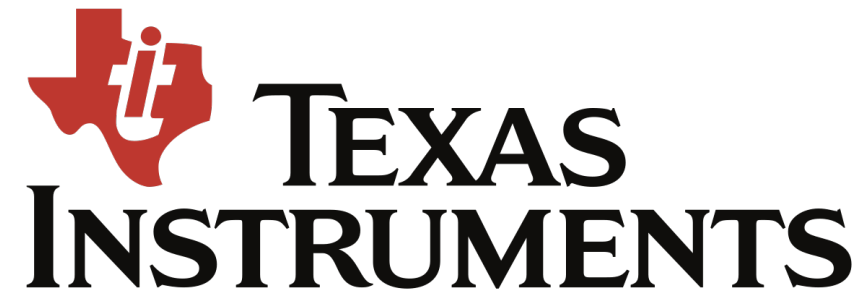

# Silicon

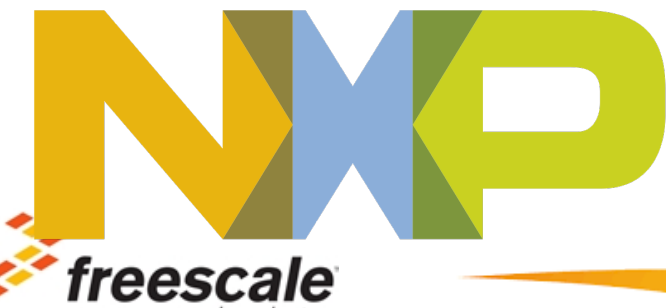

## Module-Makers (IDEK how many)

# Intermediaries



# Device

## Product-Makers



Makers 3330 registered with Bluetooth SIG as of the time of writing!

# SIG

OST2  
.FYI



DEALTEK  
**FOR SECURITY**



# Silicon



Module-Makers (IDEK how many)

# Intermediaries



Product-Makers

# Device

Makers 3330 registered with Bluetooth SIG as of the time of writing!

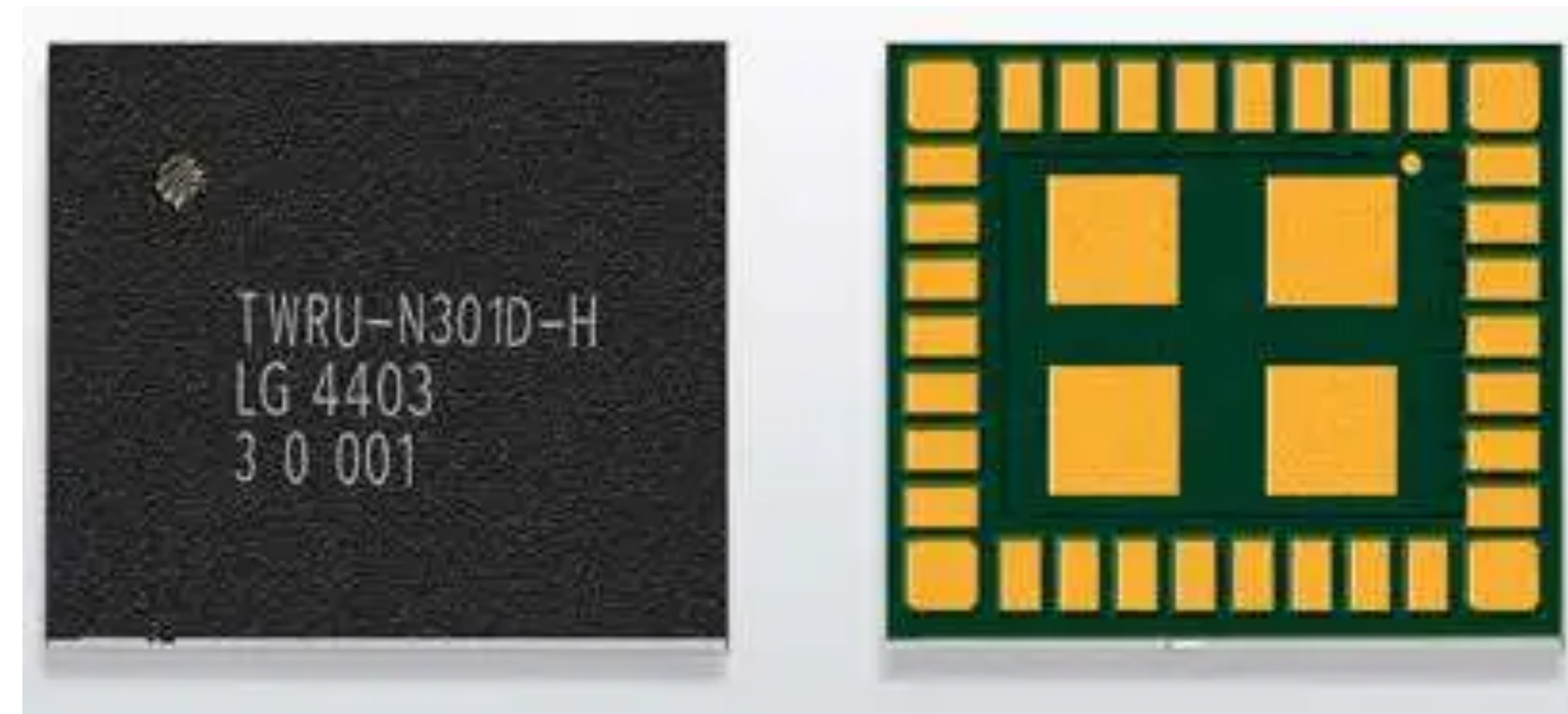

"LG Innotek has developed a Nordic nRF51822 SoC-based Bluetooth Smart (previously known as Bluetooth low energy) module"

So for my purposes, it will almost certainly present as a Nordic chip, even though it's technically custom LG silicon.



## BT5.0 Low Energy Single Mode Class 1 SoC Module

# nBlue<sup>™</sup> BR-LE5.0-S1A (nRF52840)

- **AT HOME. AT WORK. ON THE ROAD.** USING BT5.0 LOW ENERGY WIRELESS TECHNOLOGY MEANS TOTAL FREEDOM FROM THE CONSTRAINTS AND CLUTTER OF WIRES IN YOUR LIFE.
- FCC, IC, CE, RoHS, and BT5.0 Certified ISM 2.4GHz module supporting BT5.0 high speed mode, long range mode and advertising extensions. Can also support BT5.0 Mesh, 802.15.4 for Thread and Zigbee, ANT or proprietary 2.4Ghz.
- Utilizes the Nordic nRF52840 SoC. 64Mhz ARM<sup>®</sup> Cortex<sup>™</sup> M4F 32-bit processor with FPU, 1MB Flash, 256K RAM, built in DC-DC converter and ARM CryptoCell cryptographic accelerator.
- Programmable output power from -40dBm to +8dBm for short to long range applications.
- Over 1000 meter line of site distance with integrated antenna. External antenna can be connected to RF\_OUT pad or through optional u.FL connector (requires moving RF path resistor).
- Can be externally controlled via simple ASCII AT commands over UART, USB and BT5.0, or programmed with custom applications embedded in the module.

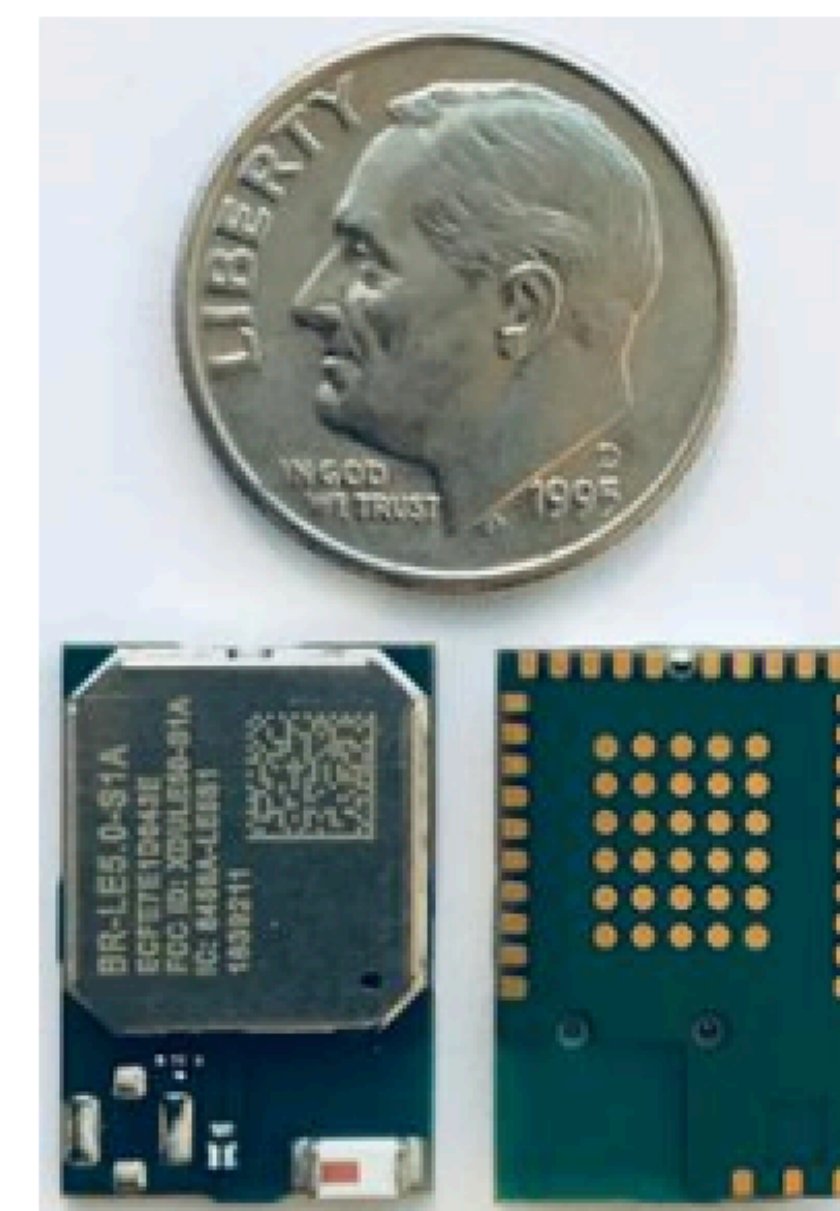



## BT5.0 Low Energy Single Mode Class 1 SoC Module

# nBlue<sup>™</sup> BR-LE5.0-S1A **nRF52840**

- **AT HOME. AT WORK. ON THE ROAD.** USING BT5.0 LOW ENERGY WIRELESS TECHNOLOGY MEANS TOTAL FREEDOM FROM THE CONSTRAINTS AND CLUTTER OF WIRES IN YOUR LIFE.
- FCC, IC, CE, RoHS, and BT5.0 Certified ISM 2.4GHz module supporting BT5.0 high speed mode, long range mode and advertising extensions. Can also support BT5.0 Mesh, 802.15.4 for Thread and Zigbee, ANT or proprietary 2.4Ghz.
- **Utilizes the Nordic nRF52840 SoC.** 64Mhz ARM<sup>®</sup> Cortex<sup>™</sup> M4F 32-bit processor with FPU, 1MB Flash, 256K RAM, built in DC-DC converter and ARM CryptoCell cryptographic accelerator.
- Programmable output power from -40dBm to +8dBm for short to long range applications.
- Over 1000 meter line of site distance with integrated antenna. External antenna can be connected to RF\_OUT pad or through optional u.FL connector (requires moving RF path resistor).
- Can be externally controlled via simple ASCII AT commands over UART, USB and BT5.0, or programmed with custom applications embedded in the module.

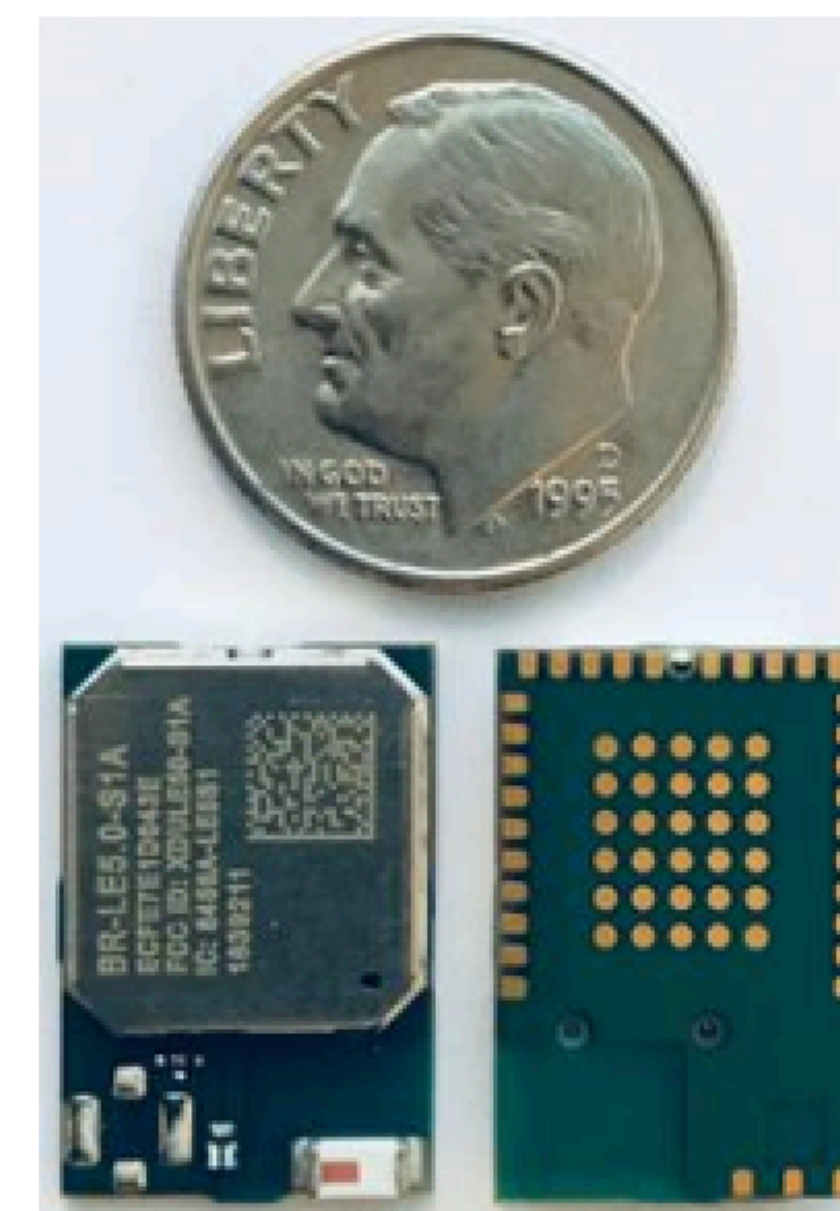

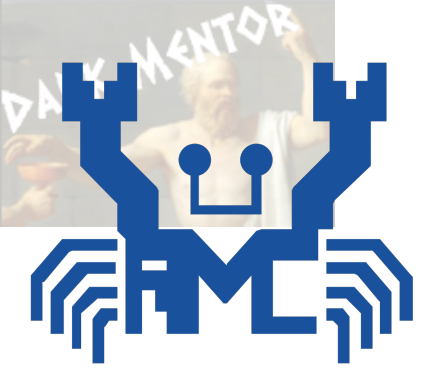

# REALTEK

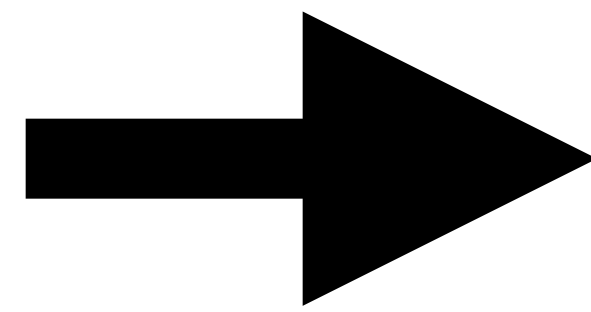

Ai-Thinker Technology

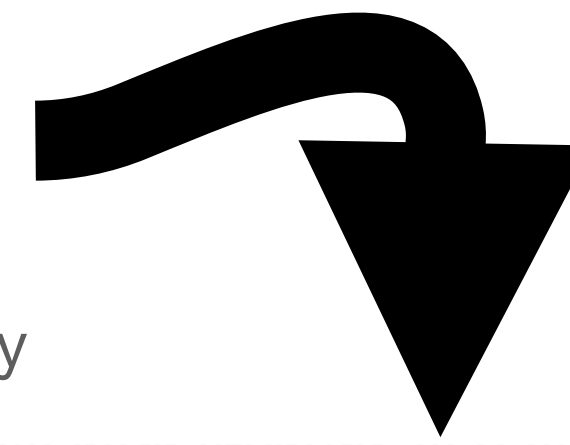

OST2  
.FYI

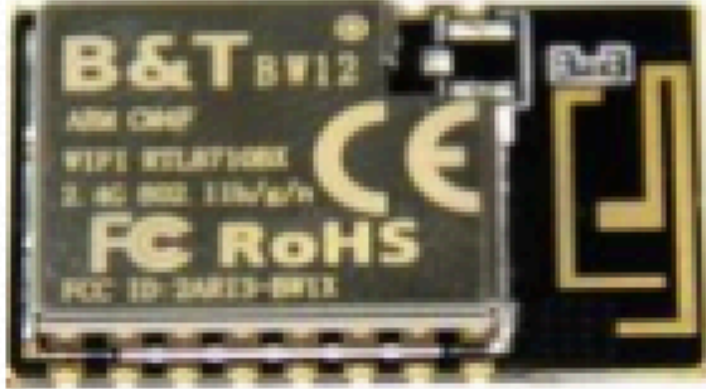
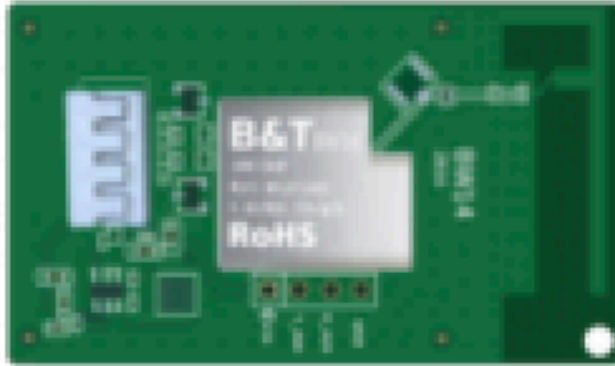
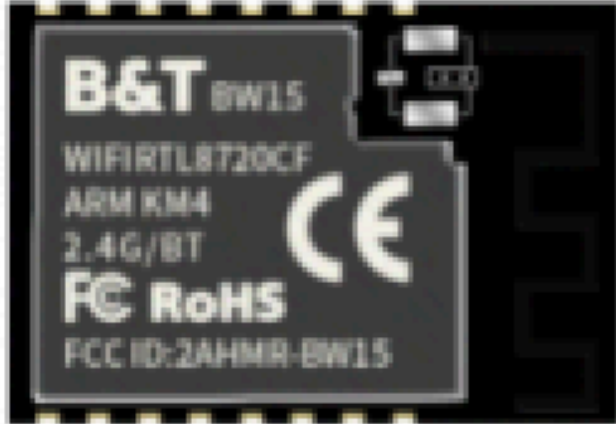
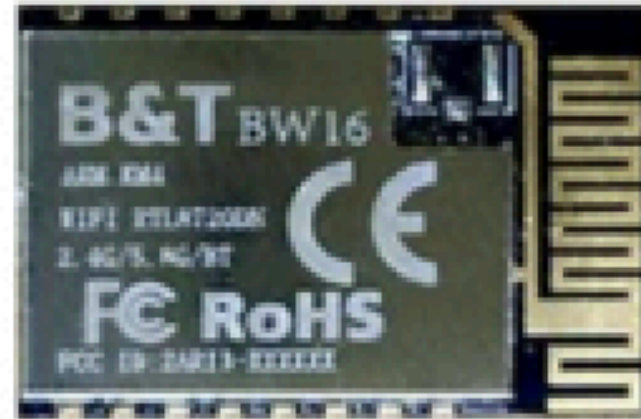
RTL87XX series				
Model	BW12	BW14	BW15	BW16 (hot)
Picture				
Chip	RTL8710BX	RTL8710BX	RTL8720CF	RTL8720DN
Package	SMT-16	/	SMD-16	SMD-16
Size	24 x16x 3mm (LxWxH) ±0.2mm	50.5*29.2*3.3 (±0.2) mm	24*16*3(±0.2)MM	24*16*3(±0.2)MM
Antenna	on-board PCB/ IPEX antenna	on-board PCB/ IPEX antenna	on-board PCB/ IPEX antenna	on-board PCB/ IPEX antenna
Frequency range	2400-2483.5MHz	2400 ~ 2483.5MHz	2.402GHz -2.480GHz	2400-2483.5MHz or 5180-5825MHz
Bluetooth	/	/	Bluetooth4.2 BLE	BLE and BT5.0
Operating temperature	-20~+85° C	-20℃~70℃	-40 °C ~ 85 °C	-20 °C ~ 70 °C
Storage temperature	-40 ~125°C	-40℃~125℃	-40 °C ~ 125 °C , < 90%RH	-40 °C ~ 125 °C , < 90%RH
Power supply	3.3±10%V	5V ~ 12V	Voltage 3.0 V ~3.6 V, current >500 mA	Voltage 3.0V ~ 3.6V, Typical 3.3V, Current >450mA
Interface	UART,I2C, SPI, GPIO, SWD, PWM	UART	UART/GPIO/ADC/PWM /IIC /SPI	UART/GPIO/ADC/PWM/IIC/SPI/SWD

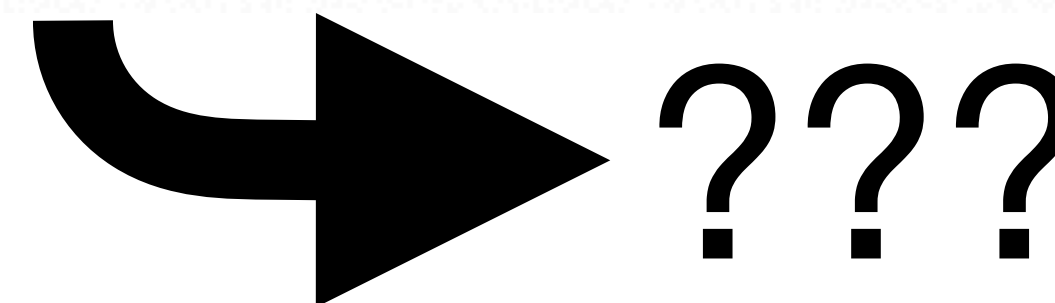





# Buying Modules vs. Chips Aside

RF Mod

	Module	Discrete/On-board	Module Benefit
RF Design	Core competency of module vendor Heavy 1-time investment of module vendor	Expertise required for layout, signal routing, layer stack-up, interference, shielding	Lower RF team needs Less board design iterations
Size	Size optimized	Non module will require larger area on target PCB	Saves board area
Procurement	1 component	Non module will increase procured BOM elements management	Reduce operational costs
Assembly	1 component	Full BOM	Reduced production cost
Test	Module fully tested	Individually tested end-product	Reduced production cost
Quality	Modules are fully tested and provided as known good	RF expertise and test flows to cover connectivity subsystem	Increased quality
Yield Loss	Pre-yielded modules	Yield losses in production Failure analysis & rework costs	Reduced production cost

## Module vs. Chip Cost

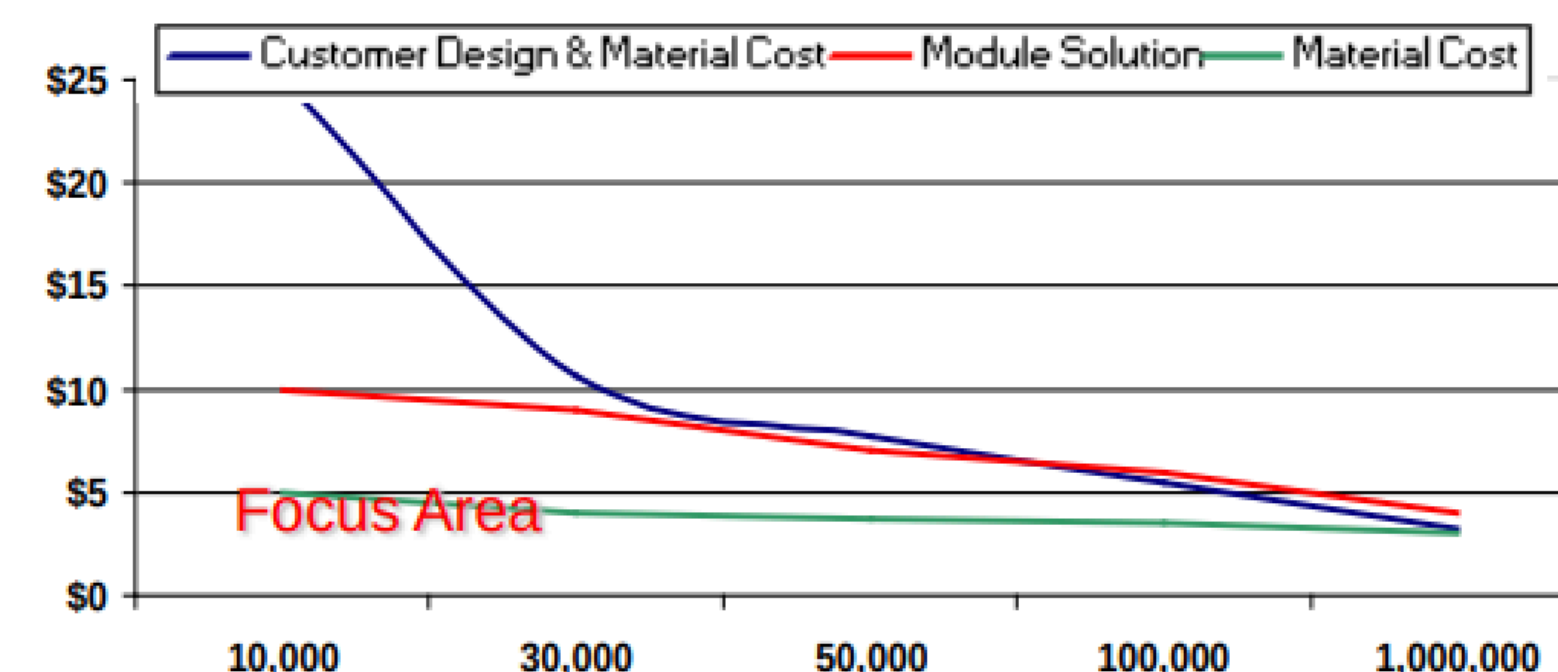

## Module Adaption Rate

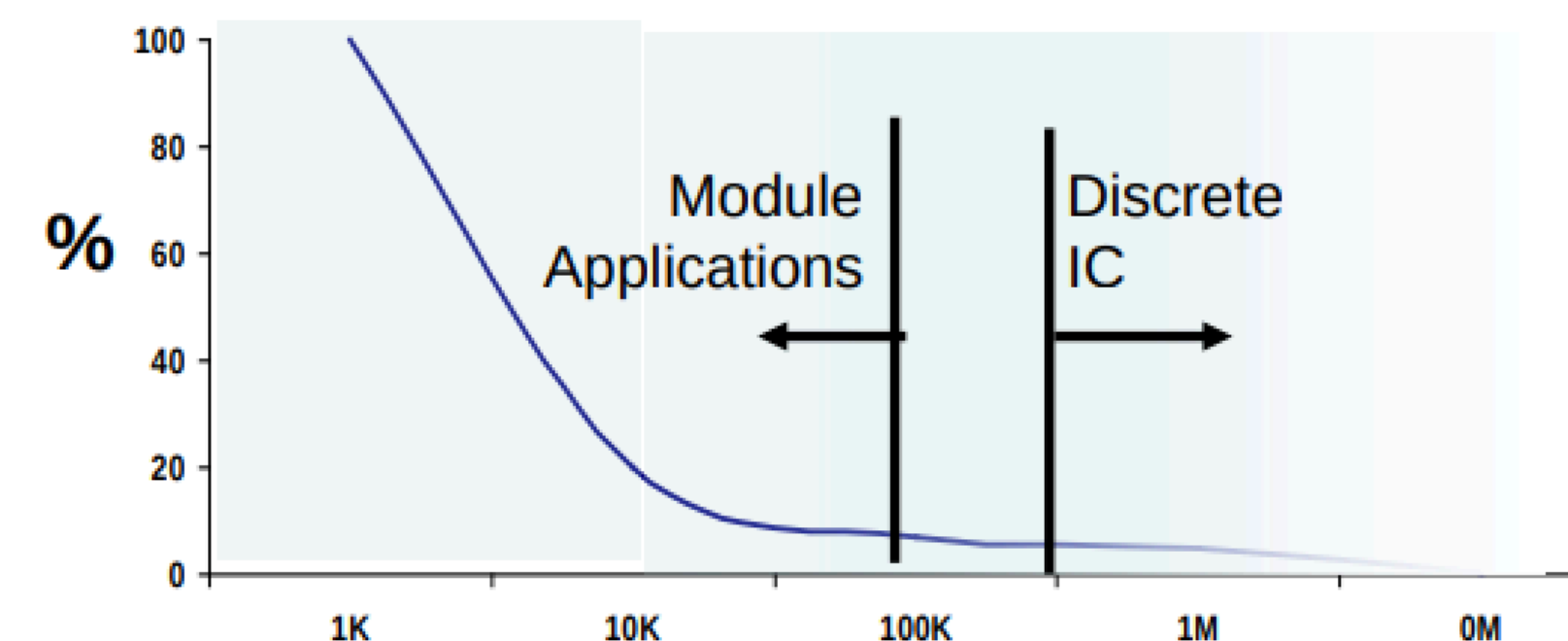



# Module vs. Chip Cost

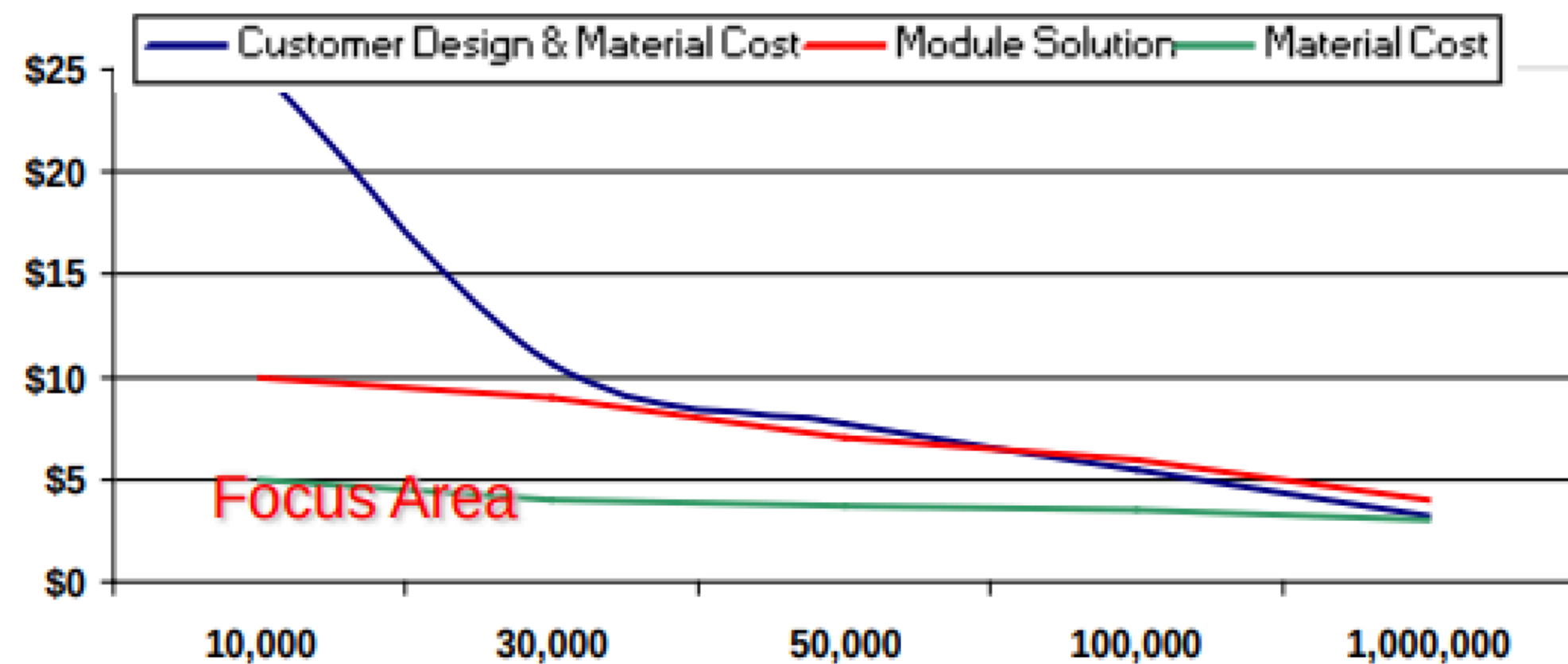

## Customer Decision: Module vs Chip

- Initial Development / RF Certification & Testing --\$181,970
  - Respin
  - Hardware Engineering
  - Firmware
  - Layout
  - Testing & Verification
  - Certification
- TOC = BOM + Mfg & Packaging

# Module Adaption Rate

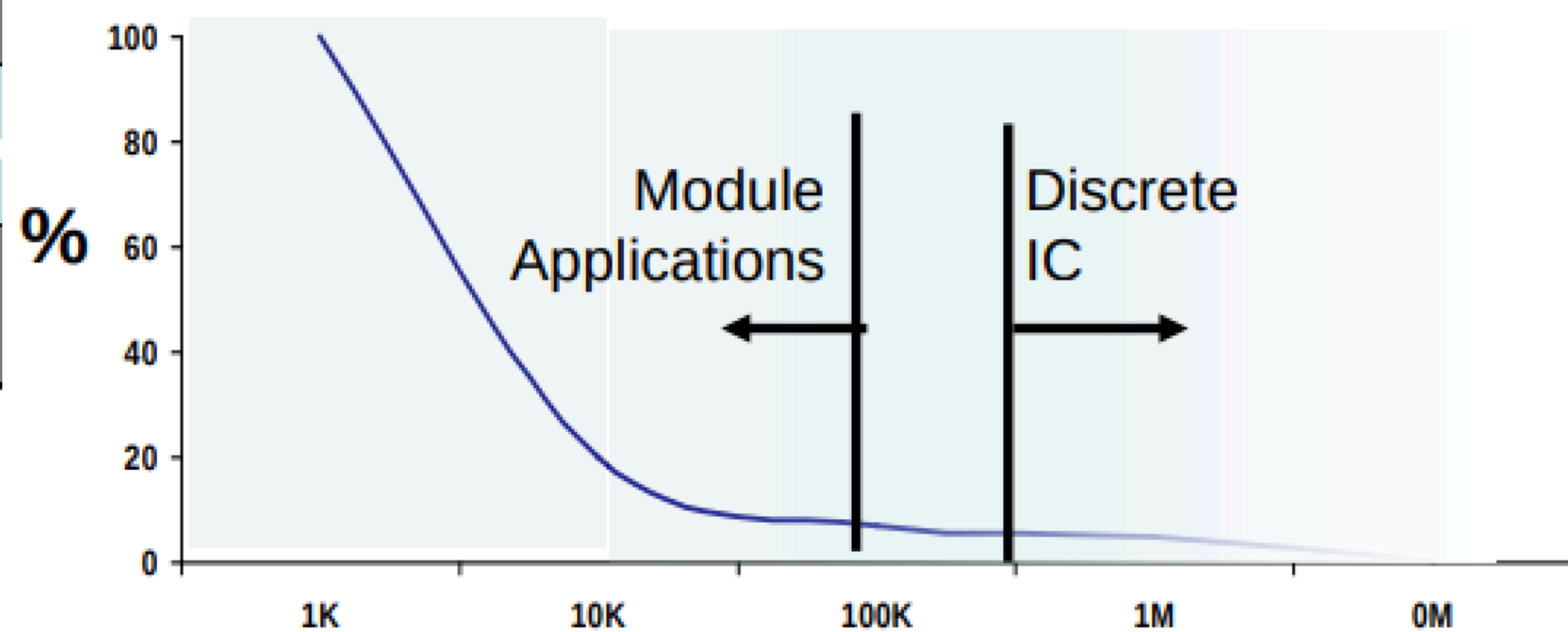

## Module Adaption Considerations

- Time to market – Modules reduce time to market.
- Product Life – Modules are the best choice for products with a long life cycle, as a module life can be extended beyond IC life cycle by using a single footprint over several generations.





**2thprint by Name**



**or**





# 2thprint by Name

## aka "*NamePrint*"

- Let's start with the easy situation, where a device more or less literally tells you what it is, based on its name
  - "Ember Ceramic Mug"
  - "Nest Cam"
  - "Versa 4"
  - "User's MacBook Pro"

# Background

## Passive Scanning 🧘

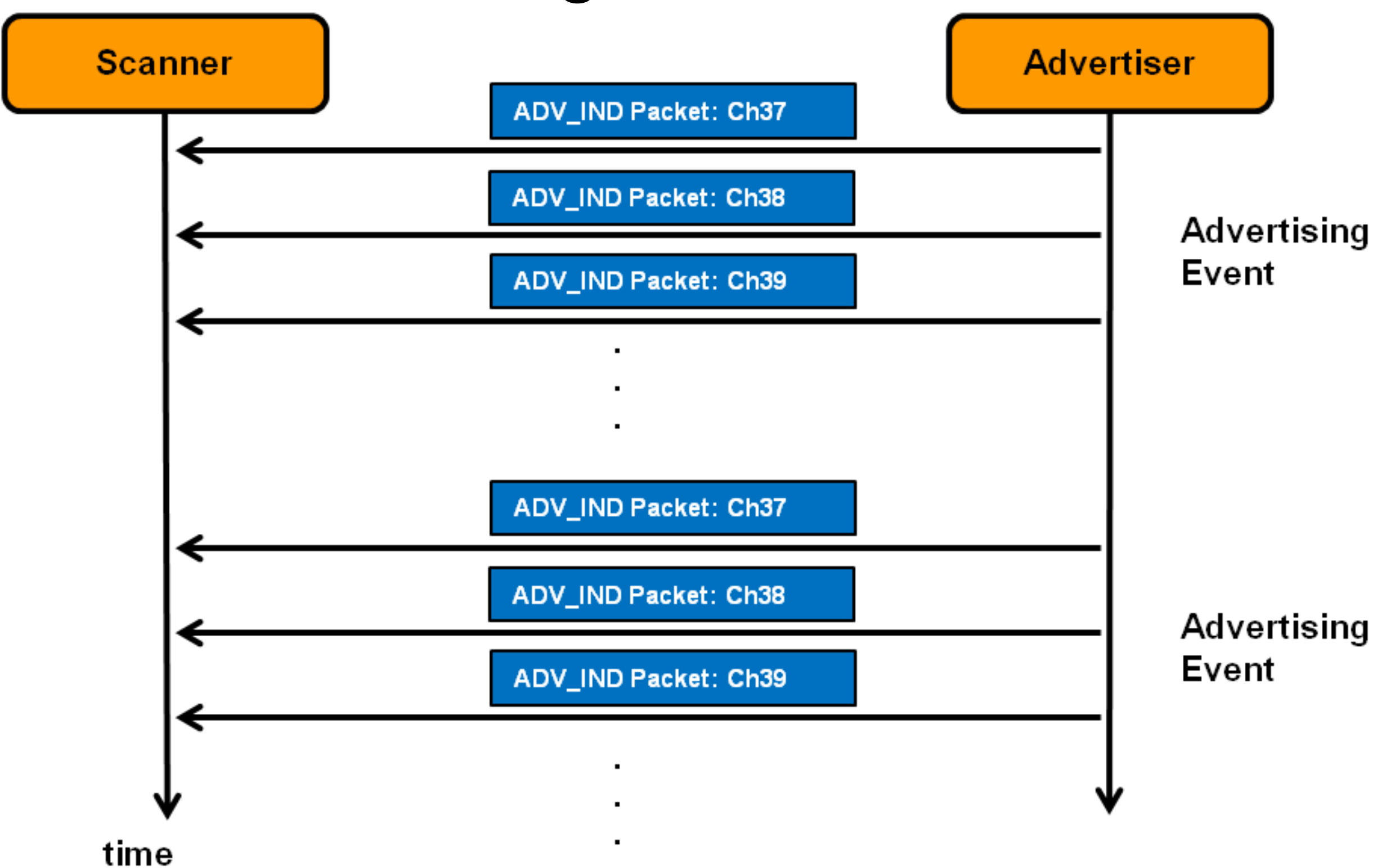

## "Mostly-passive" 🚶 Scanning

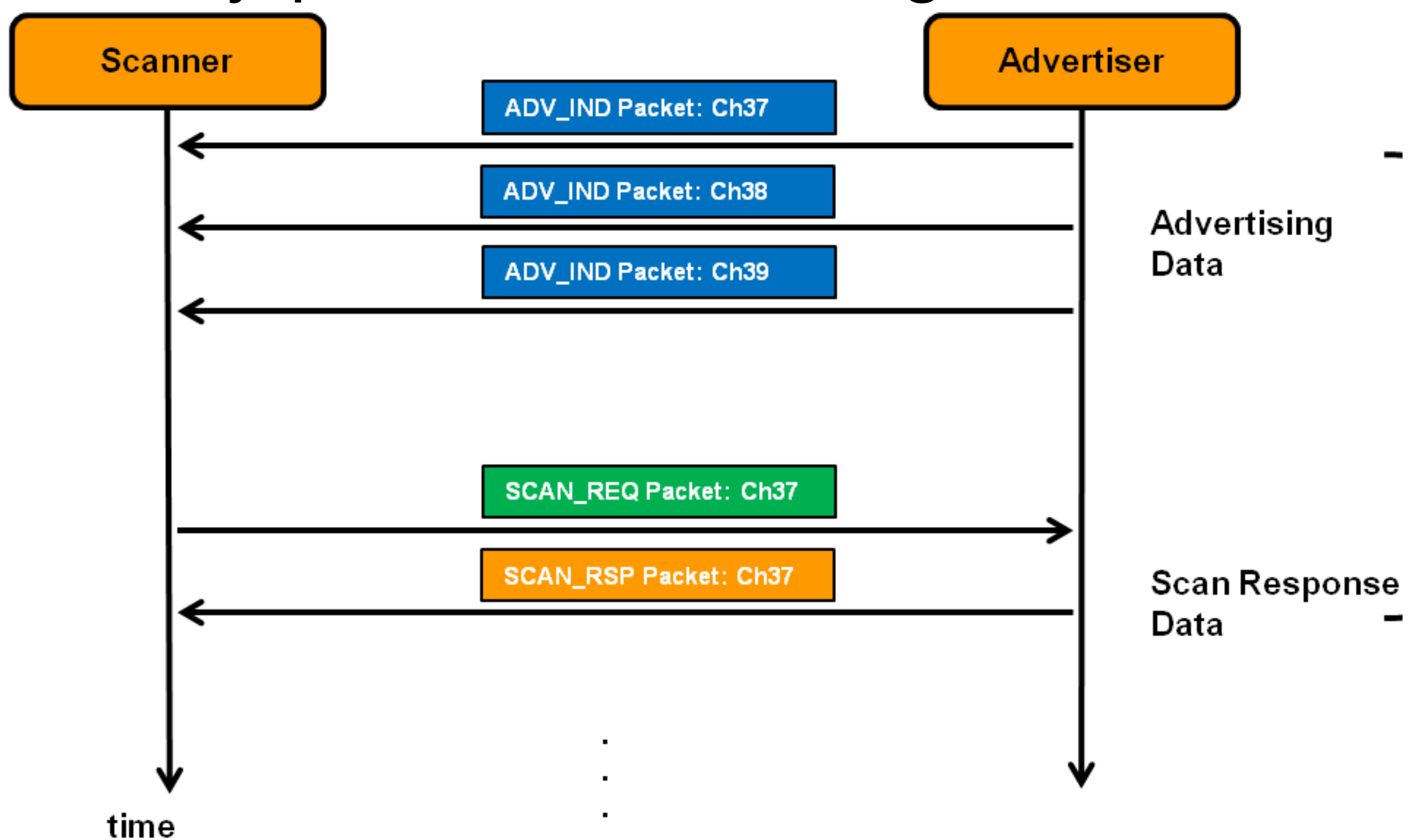

# Background

## Passive Scanning 🧘

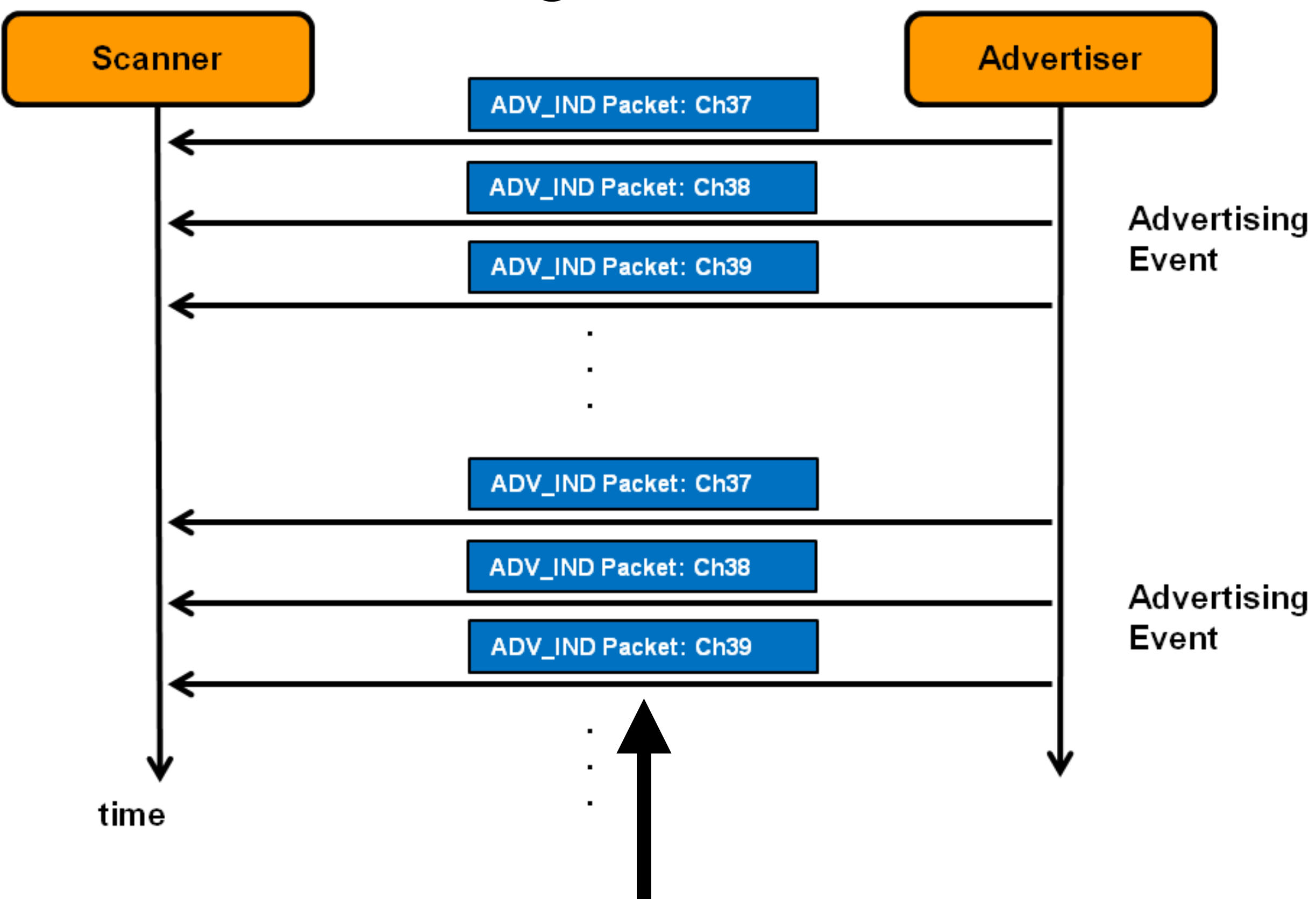

## "Mostly-passive" 🚶 Scanning

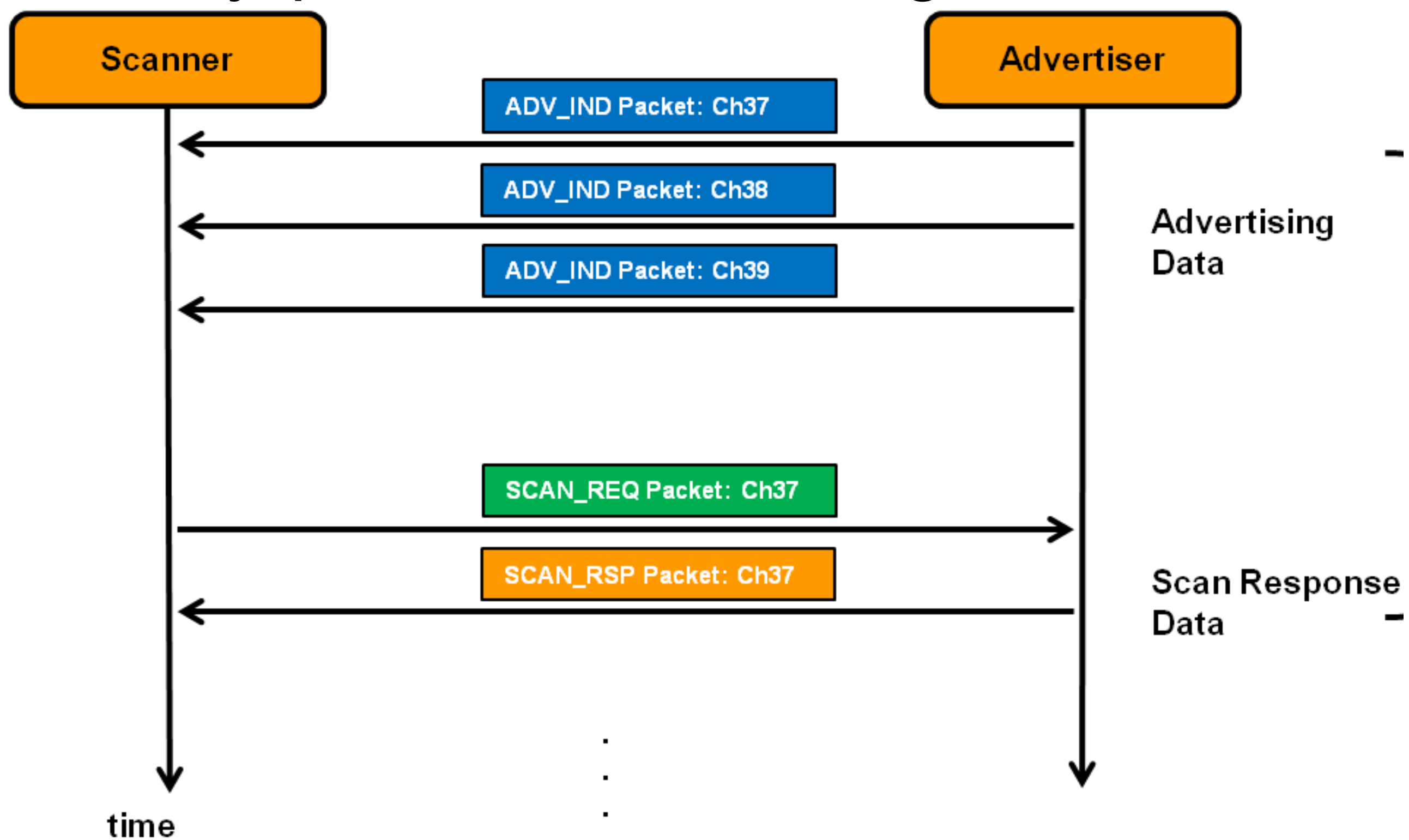

Sometimes the name will be here 🧘



# Background

## Passive Scanning 🧘

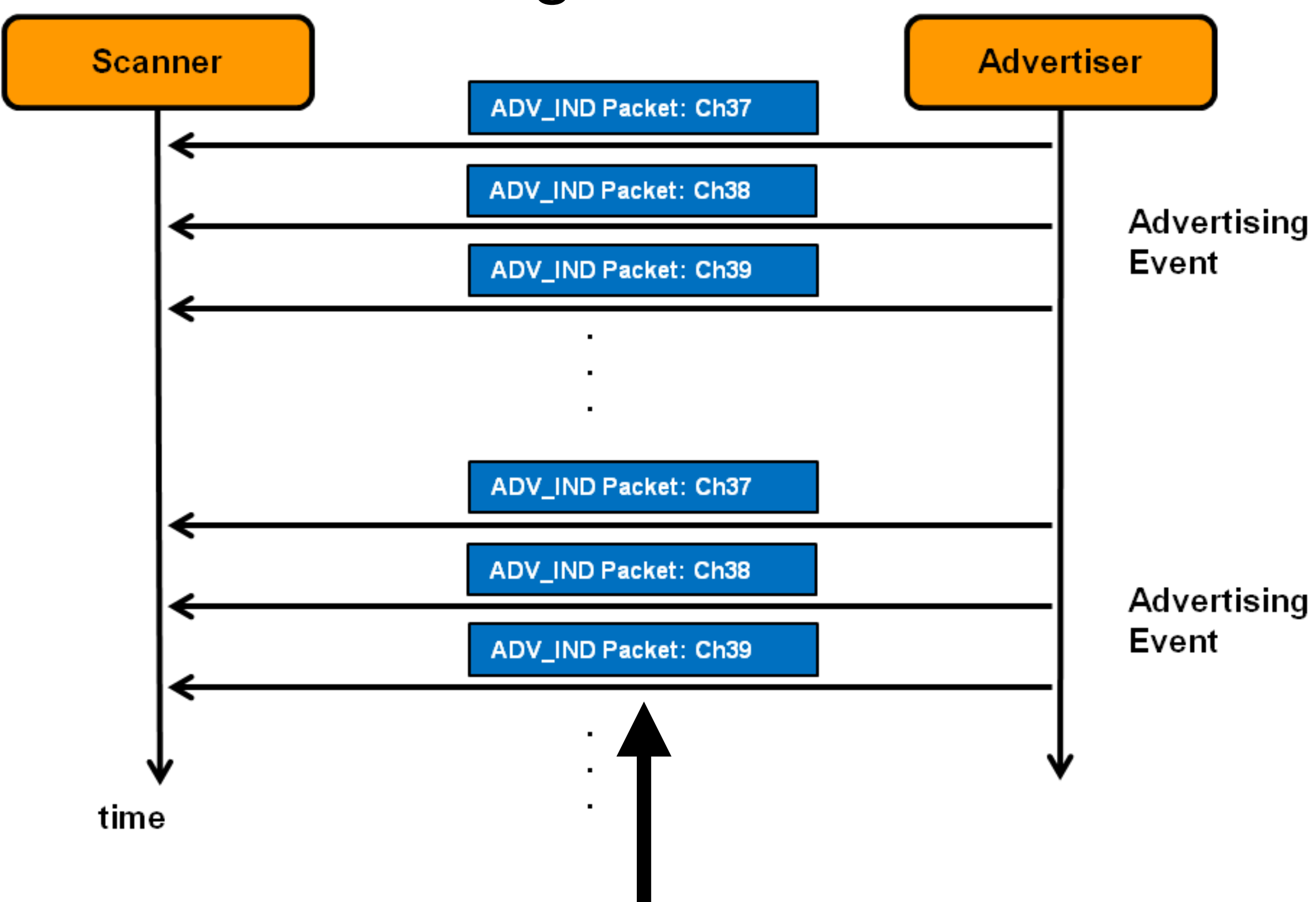

Sometimes the name will be here 🧘

## "Mostly-passive" 🚶 Scanning

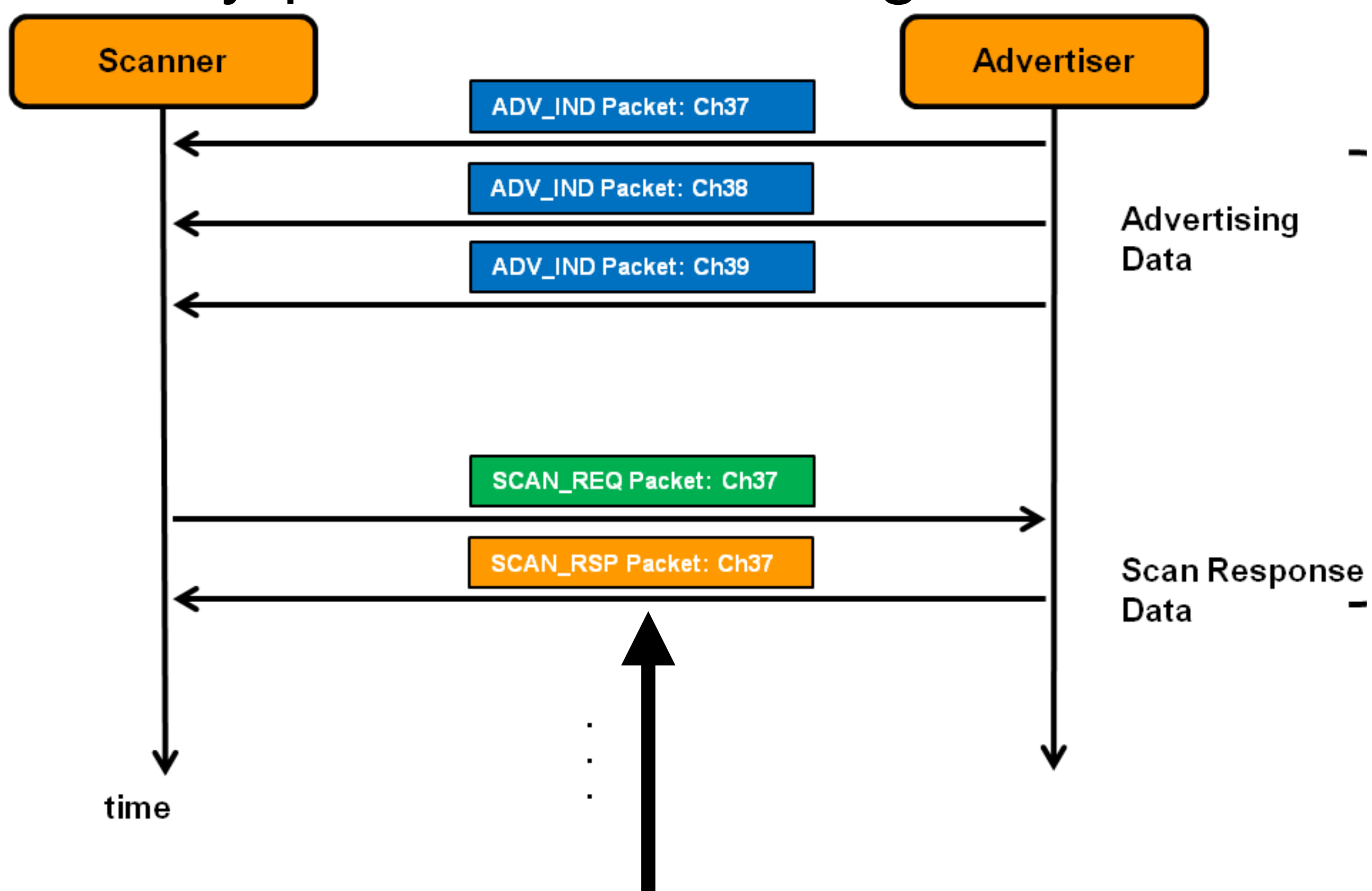

Other times the OS will ask for it 🚶, and it comes back in a SCAN\_RSP





# BT Name Behavior: One-to-One

One device == one *unique* name && one *unique* BDADDR



# BT Name Behavior: One-to-One

One device == one *unique* name && one *unique* BDADDR

**Complete** BDADDR inclusion:

<u>oura_A038F8445ED7</u>	—————→	<u>a0:38:f8:44:5e:d7</u>	(public address)
<u>NOKE3K_C8D8DCF760F6</u>	—————→	<u>c8:d8:dc:f7:60:f6</u>	(random static)



# BT Name Behavior: One-to-One

One device == one *unique* name && one *unique* BDADDR

**Complete** BDADDR inclusion:

oura_A038F8445ED7	—————→	<u>a0:38:f8:44:5e:d7</u>	(public address)
NOKE3K_C8D8DCF760F6	—————→	<u>c8:d8:dc:f7:60:f6</u>	(random static)

**Partial** BDADDR inclusion:

Galaxy Fit2 ( <u>987C</u> )	—————→	10:39:17:36: <u>98:7c</u>	(public address)
Xiaomi Smart Band 7 <u>34C1</u>	—————→	c6:05:ea:95: <u>34:c1</u>	(random static)



# BT Name Behavior: One-to-One

One device == one *unique* name && one *unique* BDADDR

**Complete BDADDR inclusion:**

oura_A038F8445ED7	—————→	<u>a0:38:f8:44:5e:d7</u>	(public address)
NOKE3K_C8D8DCF760F6	—————→	<u>c8:d8:dc:f7:60:f6</u>	(random static)

**Partial BDADDR inclusion:**

Galaxy Fit2 ( <u>987C</u> )	—————→	10:39:17:36: <u>98:7c</u>	(public address)
Xiaomi Smart Band 7 <u>34C1</u>	—————→	c6:05:ea:95: <u>34:c1</u>	(random static)

**(Presumed) serial number inclusion**

TW370_TIA00414	—————→	4c:36:4e:4c:57:2a	(public address)
CATBTNT-04 DKS02390	—————→	00:81:f9:7e:37:a6	(public address)



# BT Name Behavior: One-to-One

One device == one *unique* name && one *unique* BDADDR



# BT Name Behavior: One-to-One

One device == one *unique* name && one *unique* BDADDR

*Possible* partial BDADDR disclosure?:

Galaxy Watch Active2(C898) LE → c0:b9:b5:02:10:31 (random static)



# BT Name Behavior: One-to-Many

One device == one *unique* name && many BDADDRs  
(exclusive to BLE random addresses)

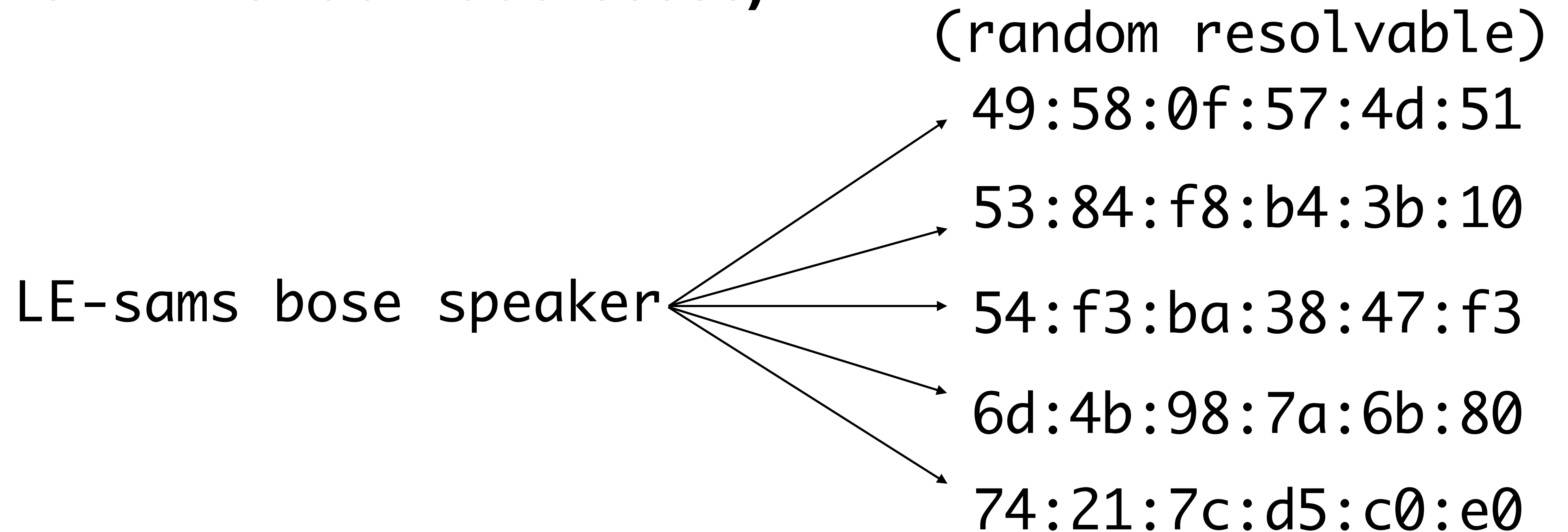



# BT Name Behavior: Many-to-Many v1

Many devices, one *shared* name, one *unique* BDADDR per device

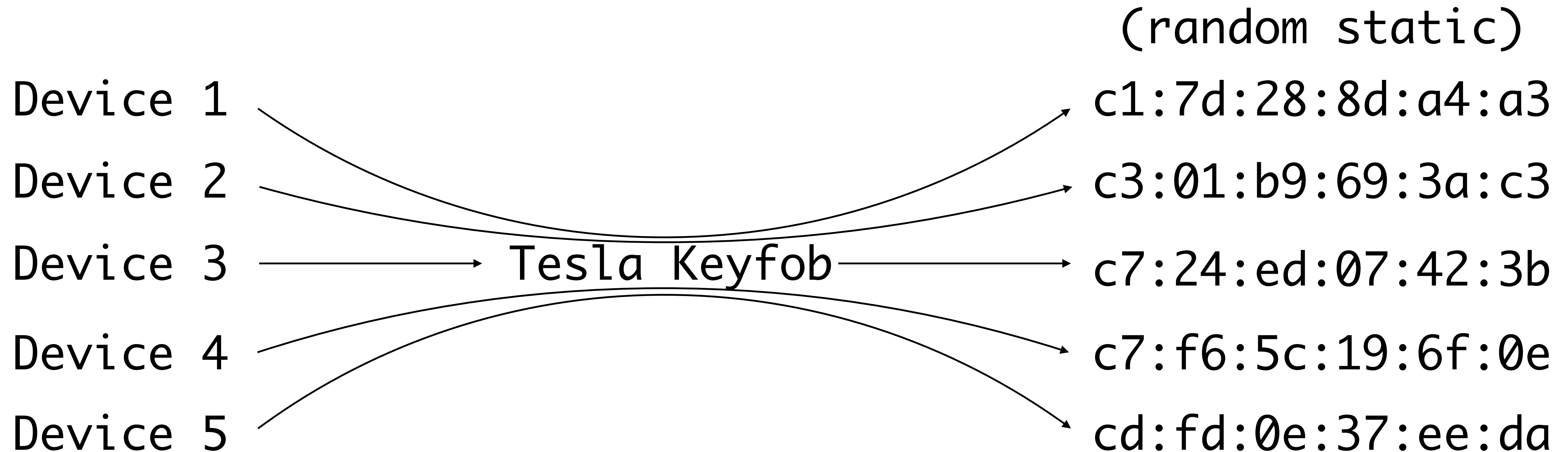

Example: Tesla Keyfob





# BT Name Behavior: Many-to-Many v2

Many devices, one *shared* name, *many* BDADDR per device

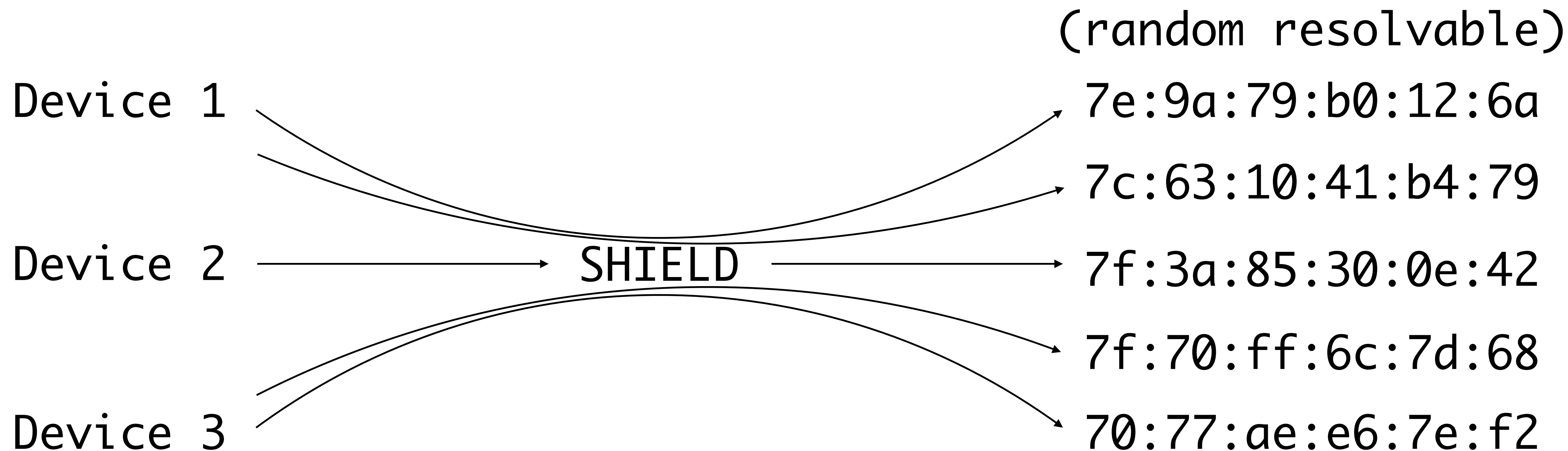

Example: Nvidia SHIELD



# NamePrint Data

## BTC as of 2023-10-26

- I wrote 1,447 regex "NamePrints"
  - 557 NamePrints matched on BTC data
- 65,451 *unique* BT Classic BDADDRs with a name
  - 65,744 *unique* {name:BDADDR} pairs
    - 23,803 NamePrint matches
      - $23,803 / 65,744 = 36\%$  of all BTC data
- 33,368 *unique names* in BTC data

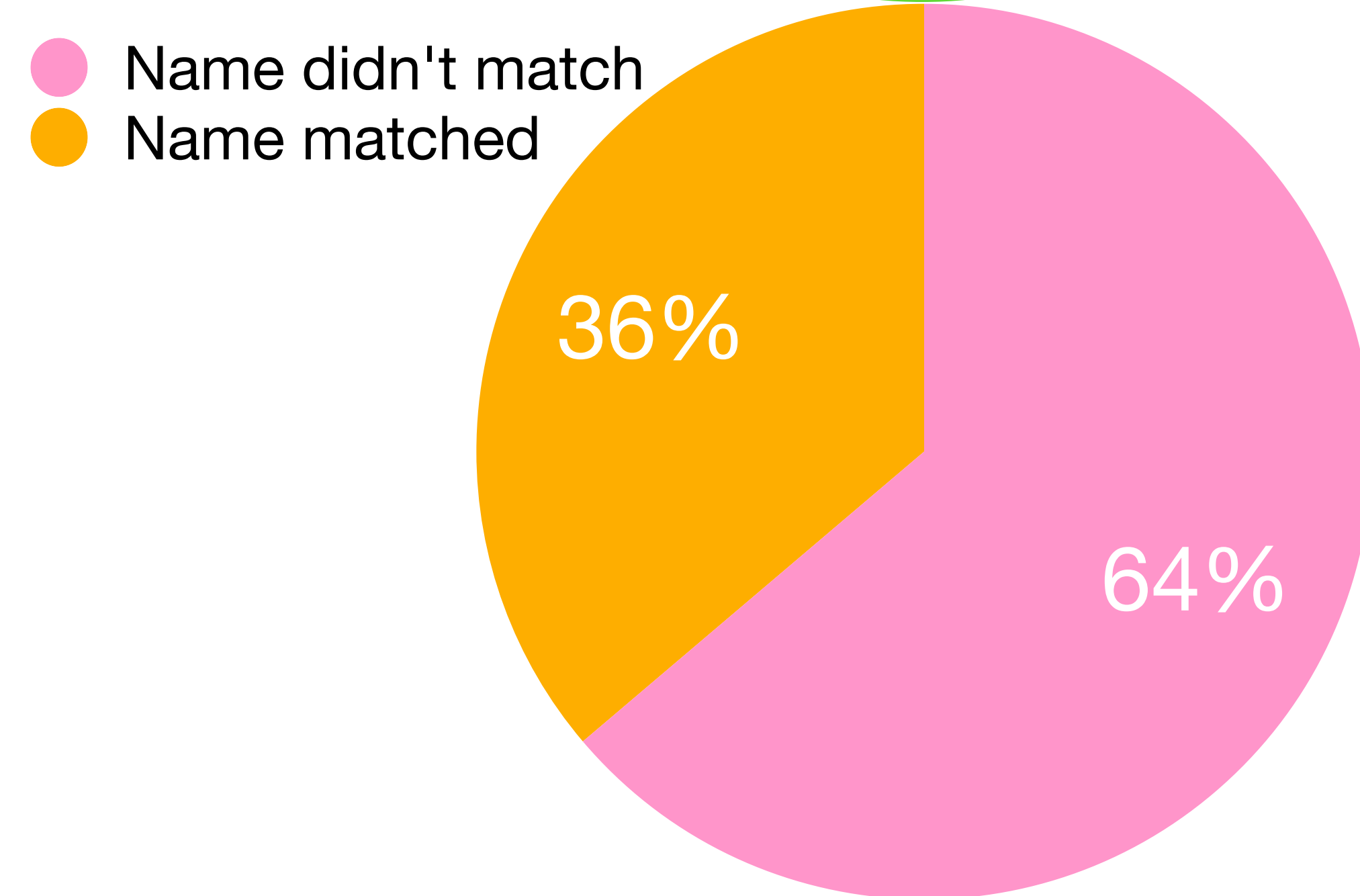
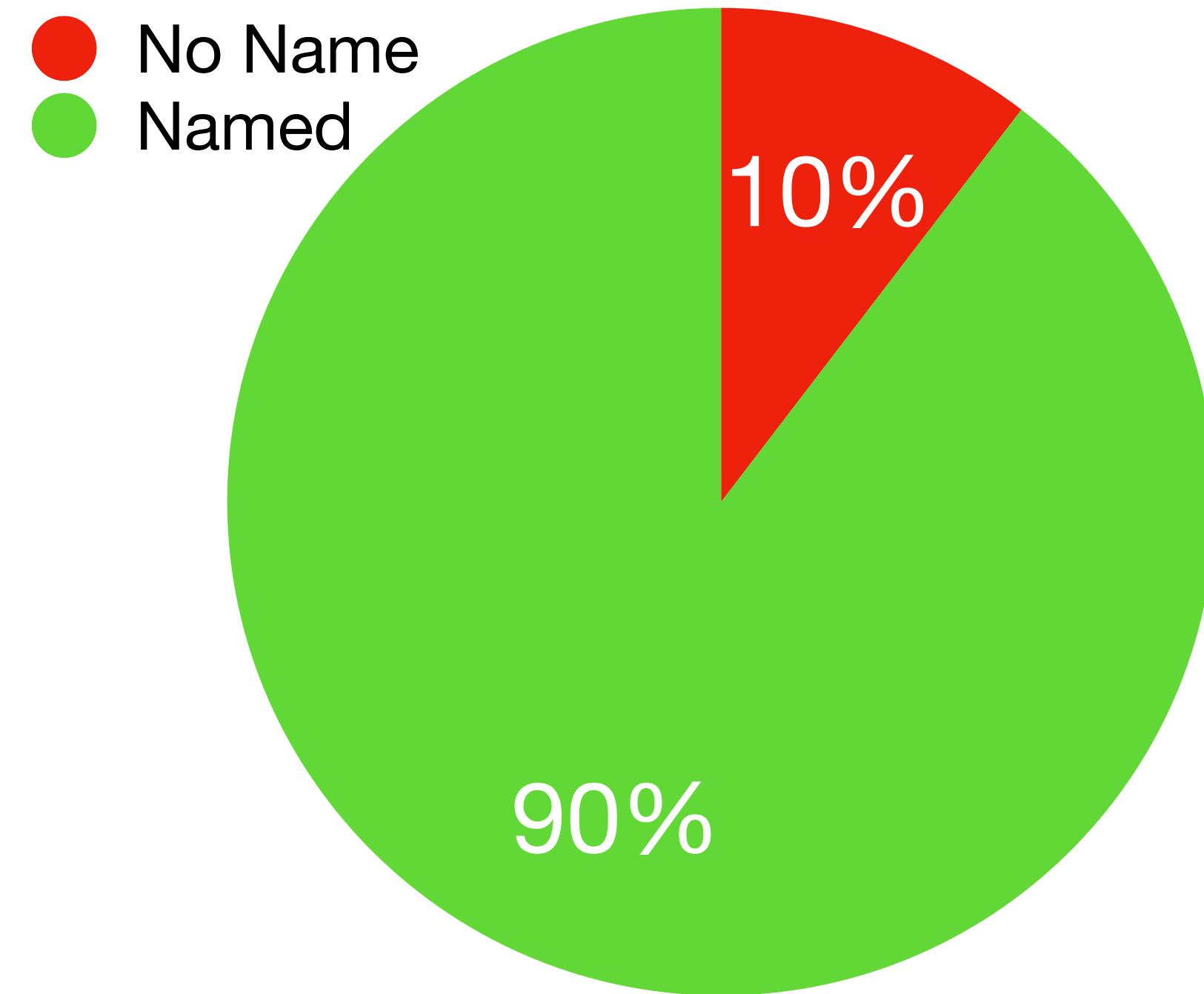

How can there be more bdaddr:name pairs than bdaddrs? Multiple names per bdaddr! (Often due to receiving corrupt name data.)

How can there be more names than matches? Because NamePrints are regexes, one NamePrint matches multiple names



# Top 10 BTC Matches

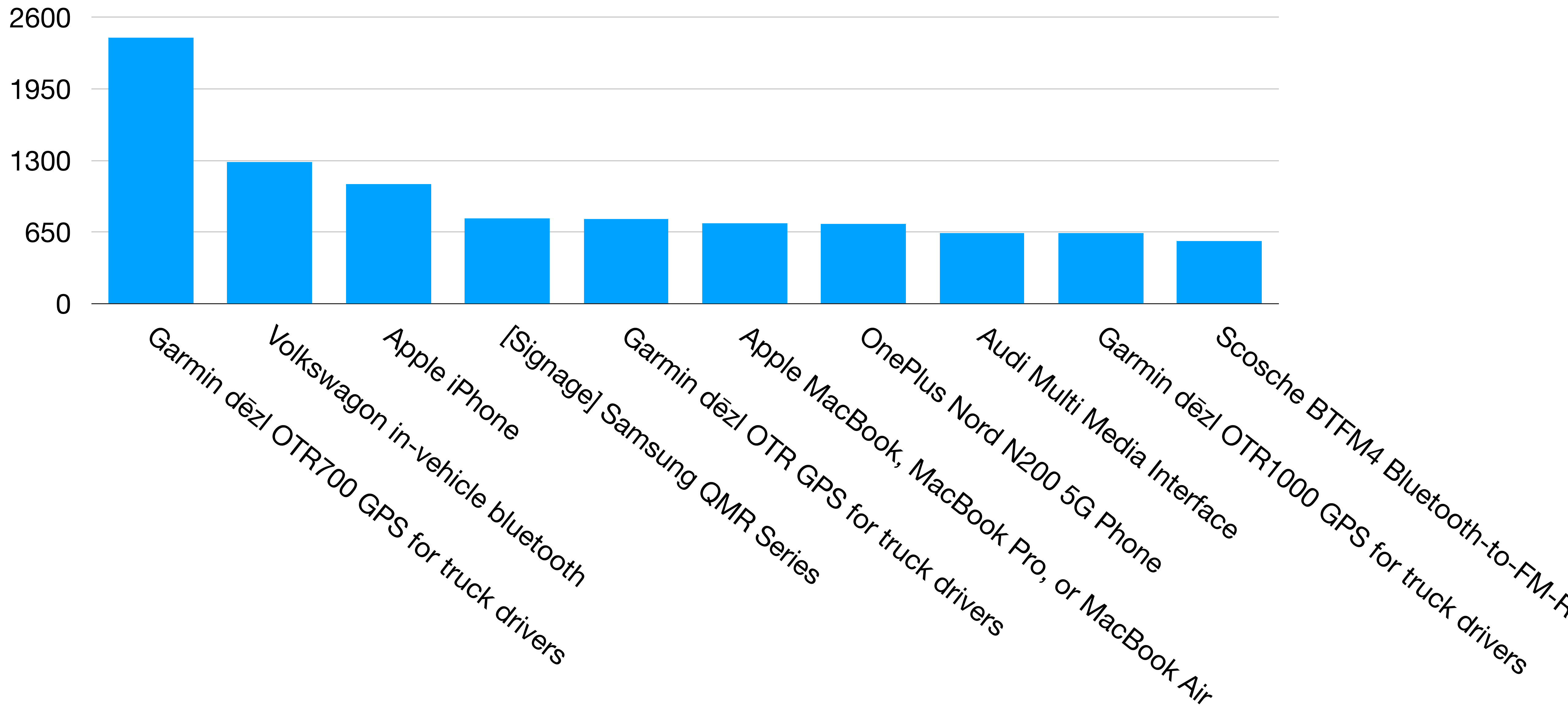



# Summary of BTC NamePrint % applicability

- 36% of 90% of 1% (.324%) of all my data is BTC with a name that matches a NamePrint

● BLE      ● BTC

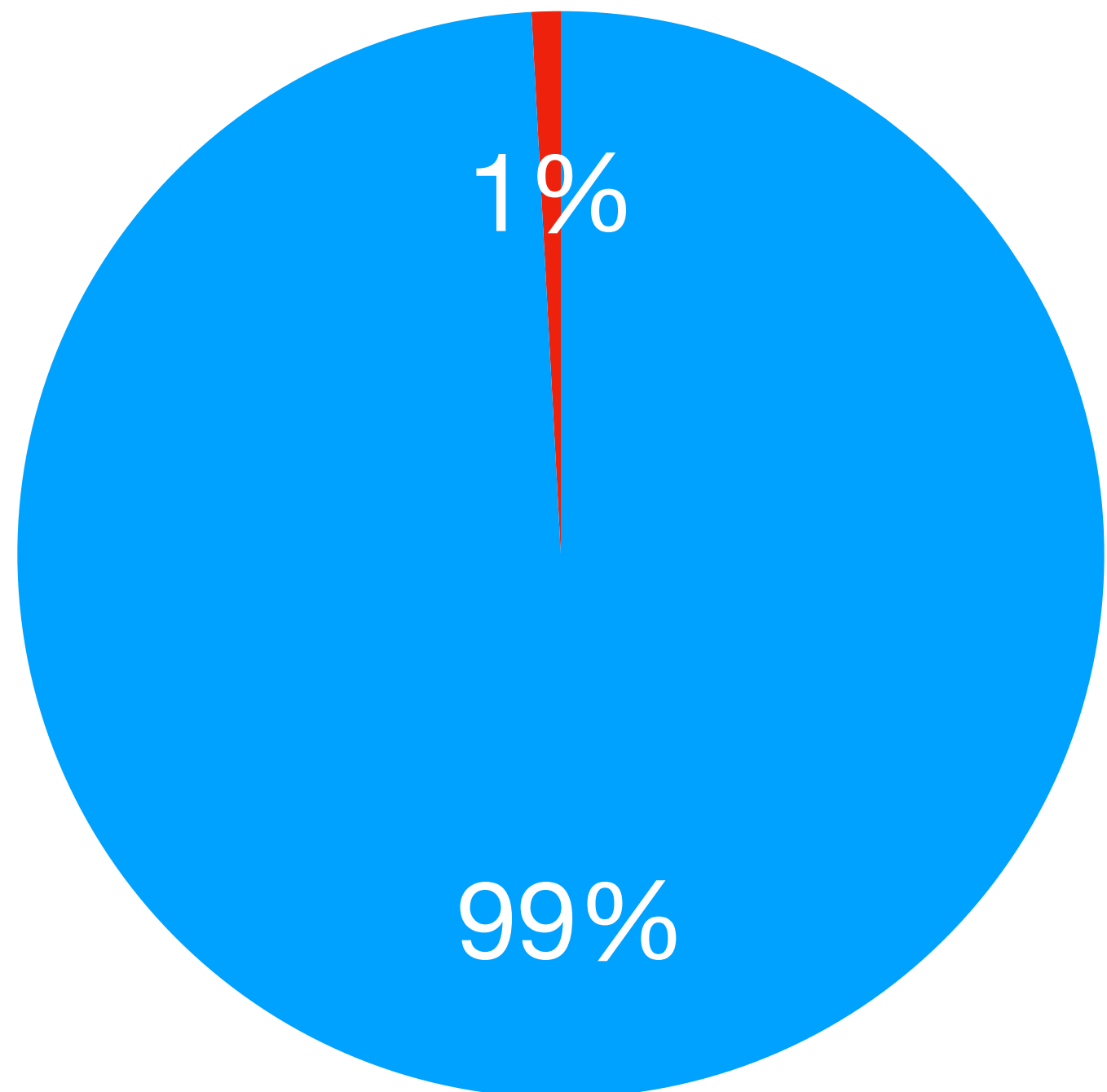

● BTC No Name      ● BTC Named

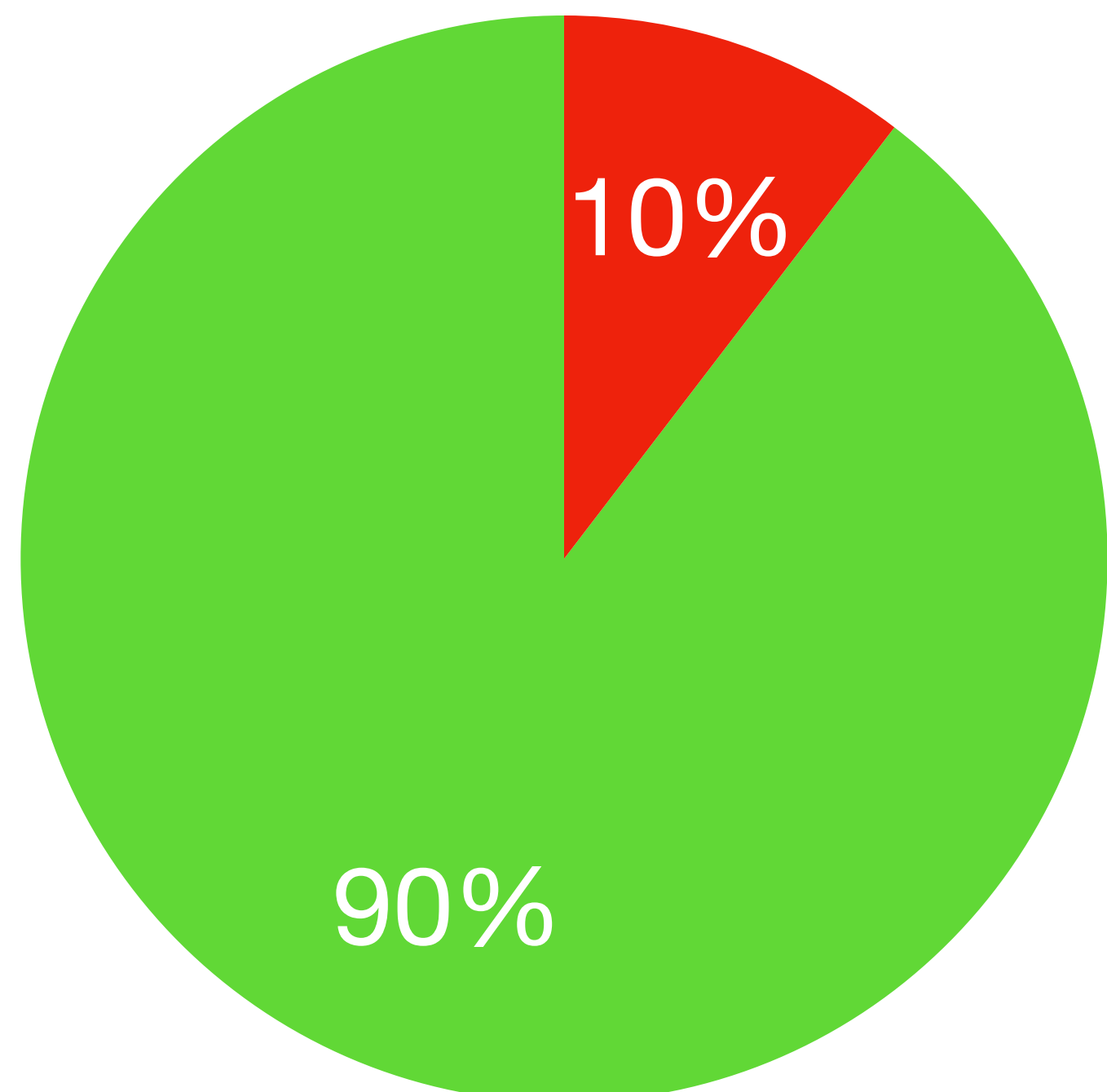

● Name didn't match  
● Name matched

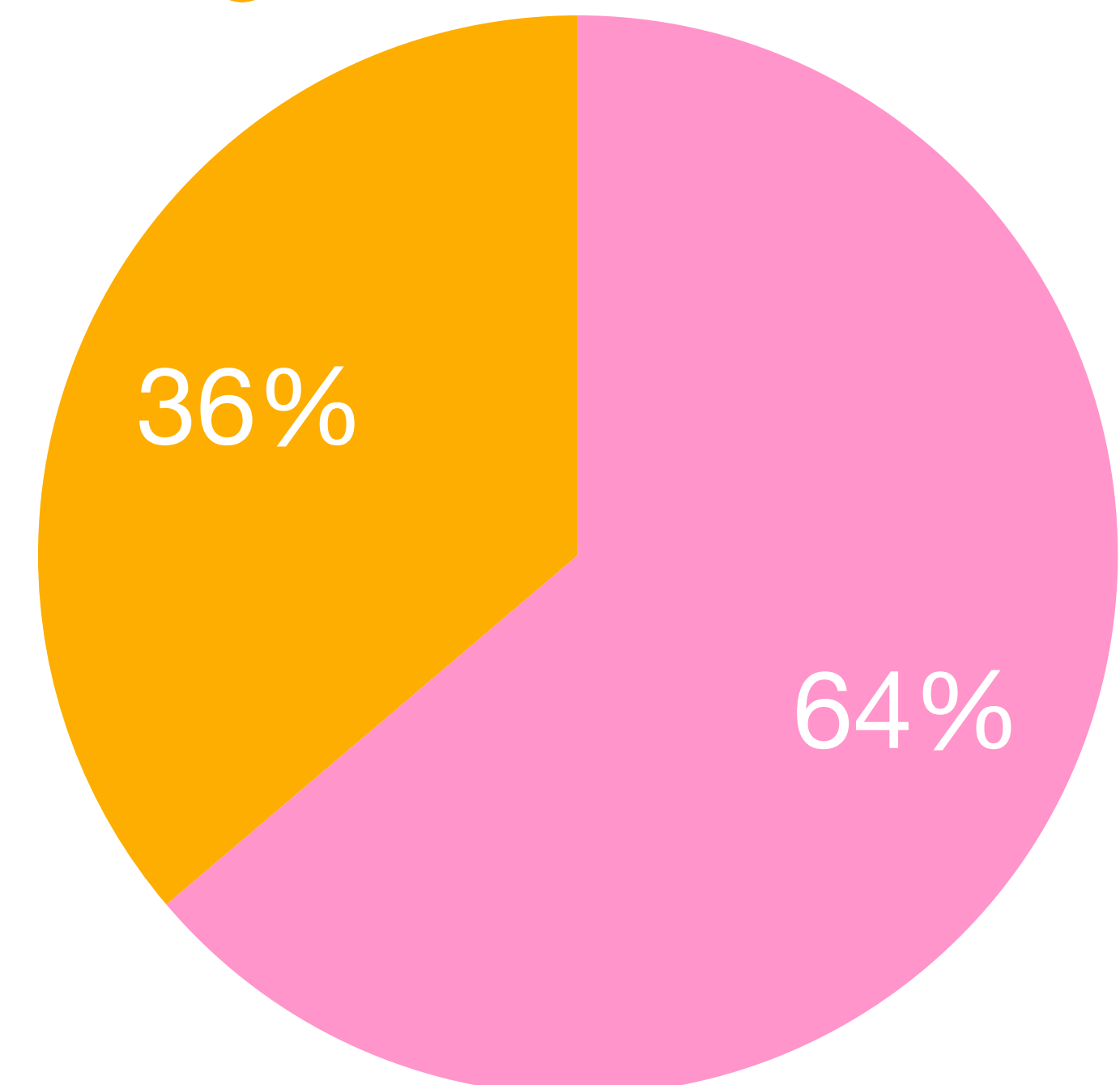



# NamePrint Data

## BLE as of 2023-10-26

- **Made 1447 regex "NamePrints"**
  - 912 NamePrints matched on BLE data
- 188,059 *unique* BLE BDADDRs with a name
  - 195,954 *unique* name:BDADDR pairs
    - 123,865 matches
      - 39% of named data, 1.7% of all BTC data
  - 18,959 *unique names*
    - So 540 regexes match 18959/37939 ~ 50% of the names

● No Name  
● Named

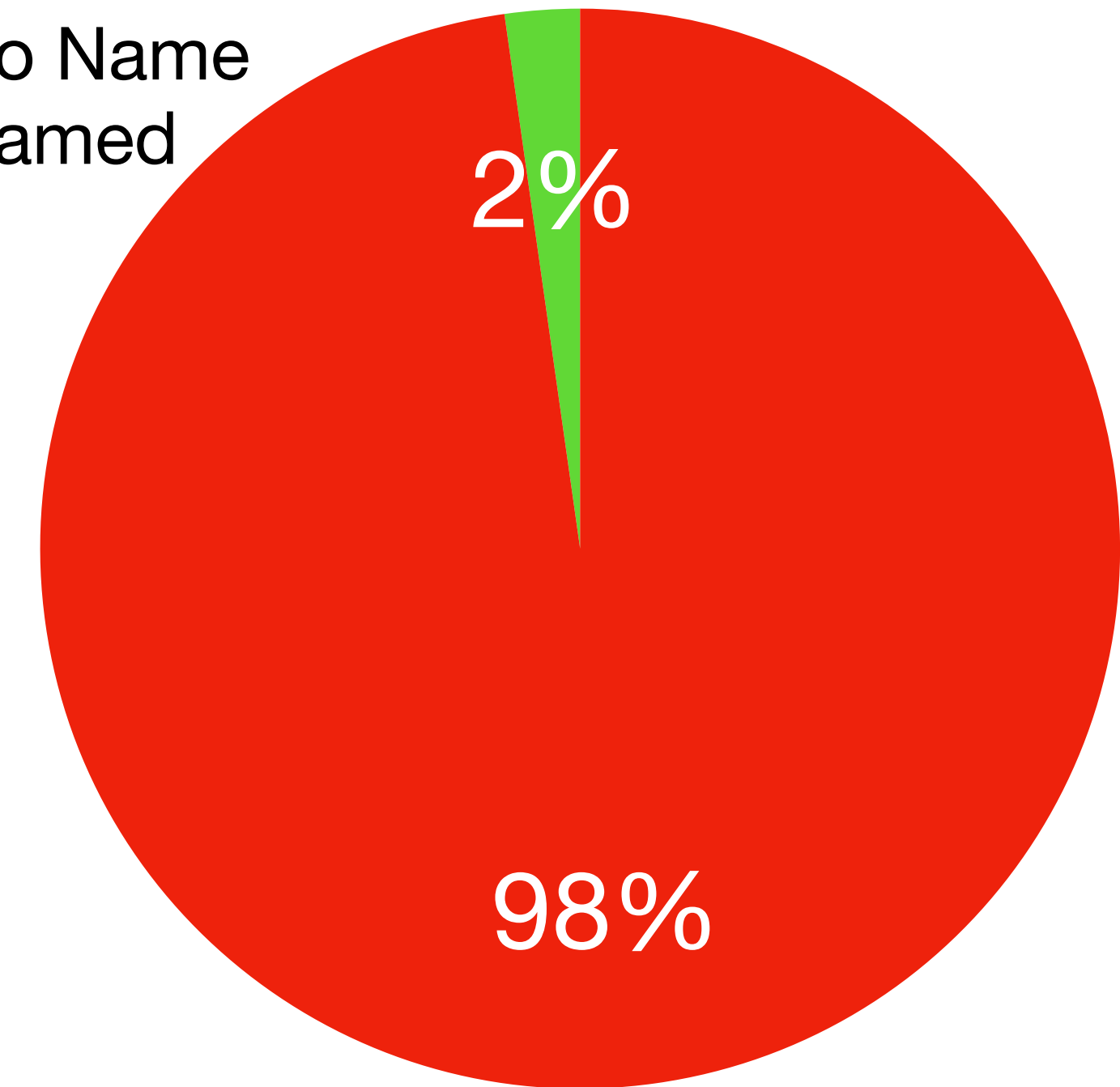

● Name didn't match  
● Name matched

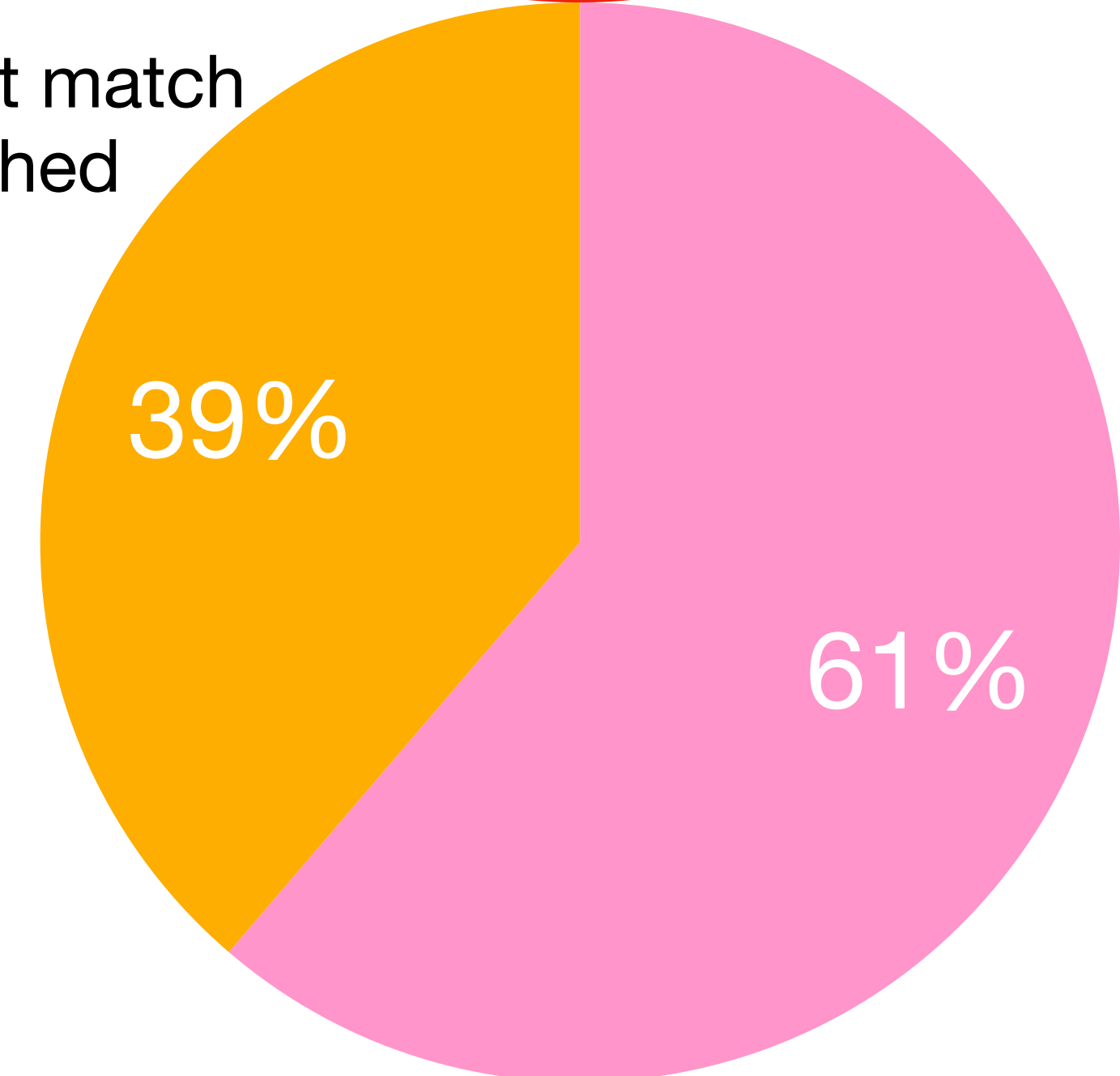

How can there be more bdaddr:name pairs than bdaddrs? Multiple names per bdaddr! (Often due to receiving corrupt name data.)

How can there be more names than matches? Because NamePrints are regexes, one NamePrint matches multiple names



# Top 10 BLE Matches

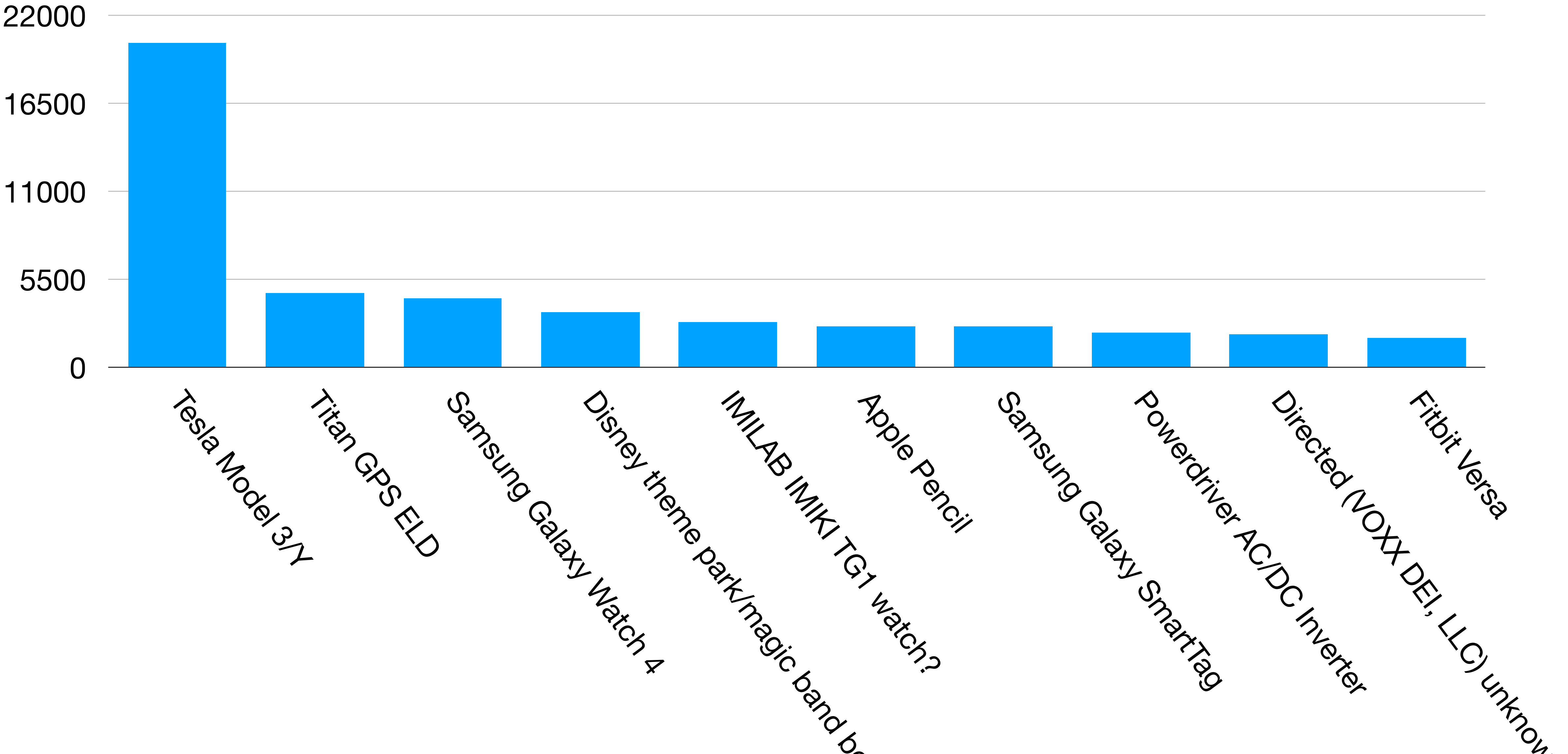



# Summary of BTC NamePrint % applicability

- 39% of 2% of 99% (7.128%) of all my data is BLE with a name that matches a NamePrint

● BLE

● BTC

● BLE No Name

● BLE Named

● Name didn't match

● Name matched

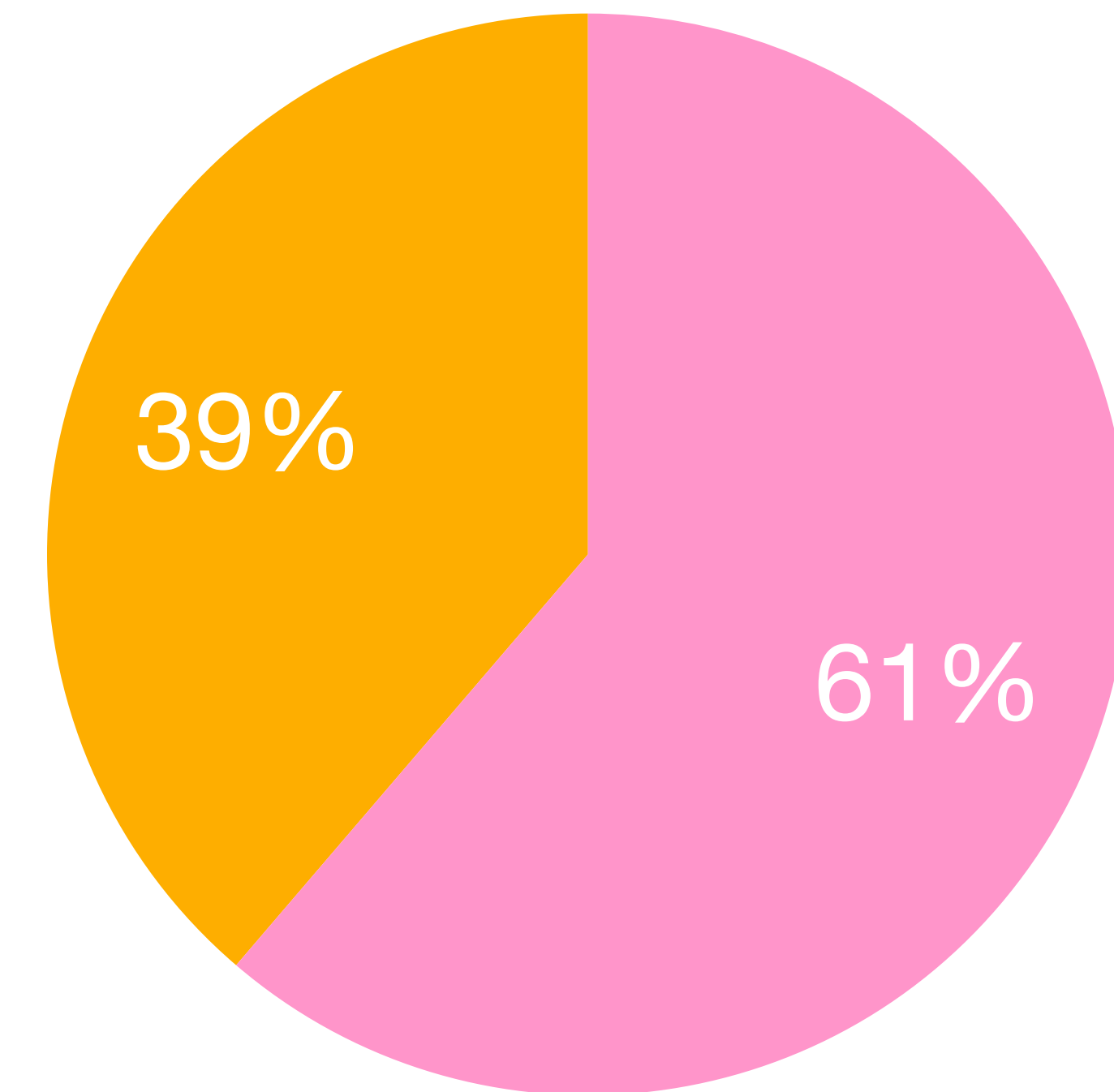
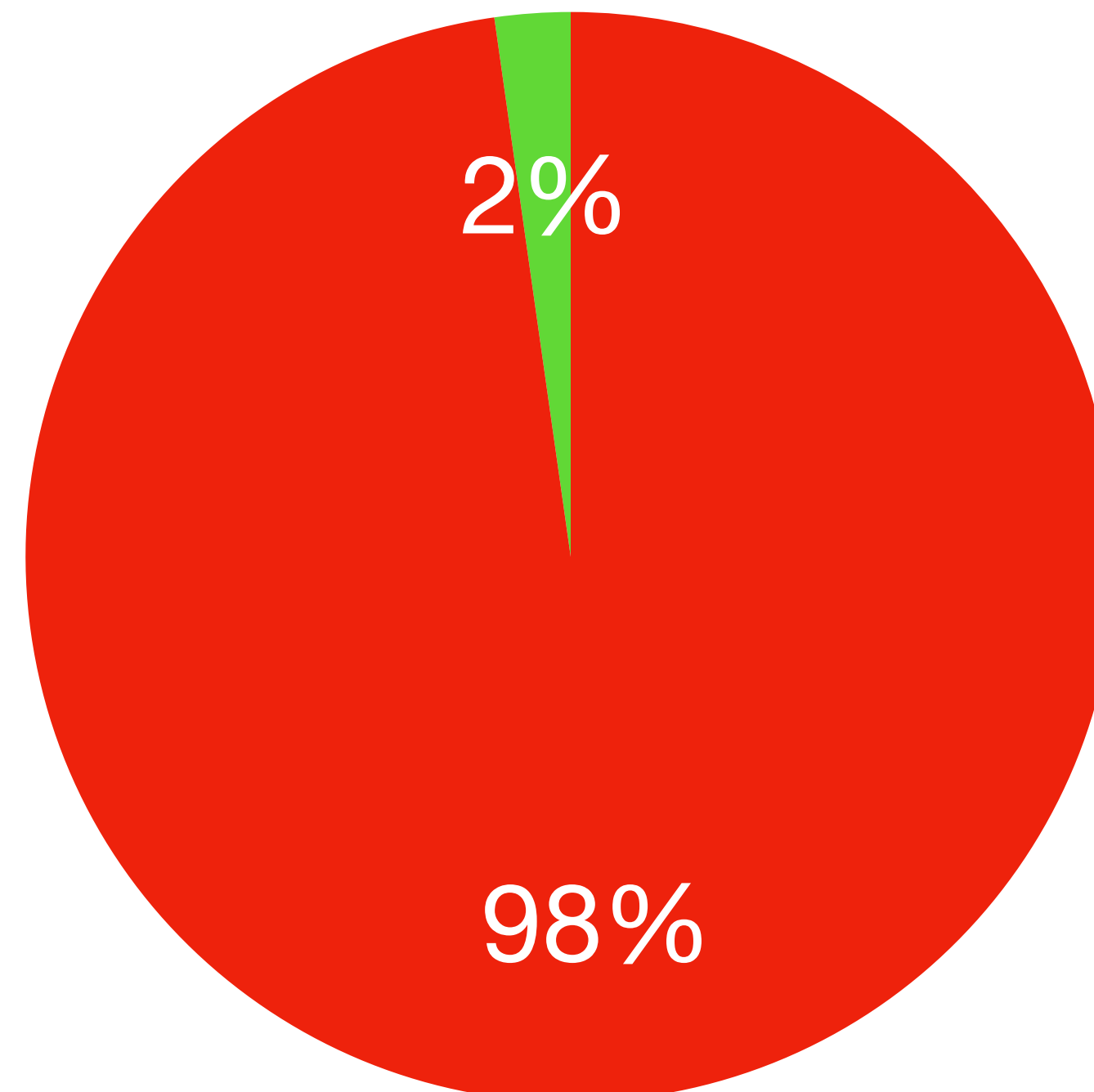
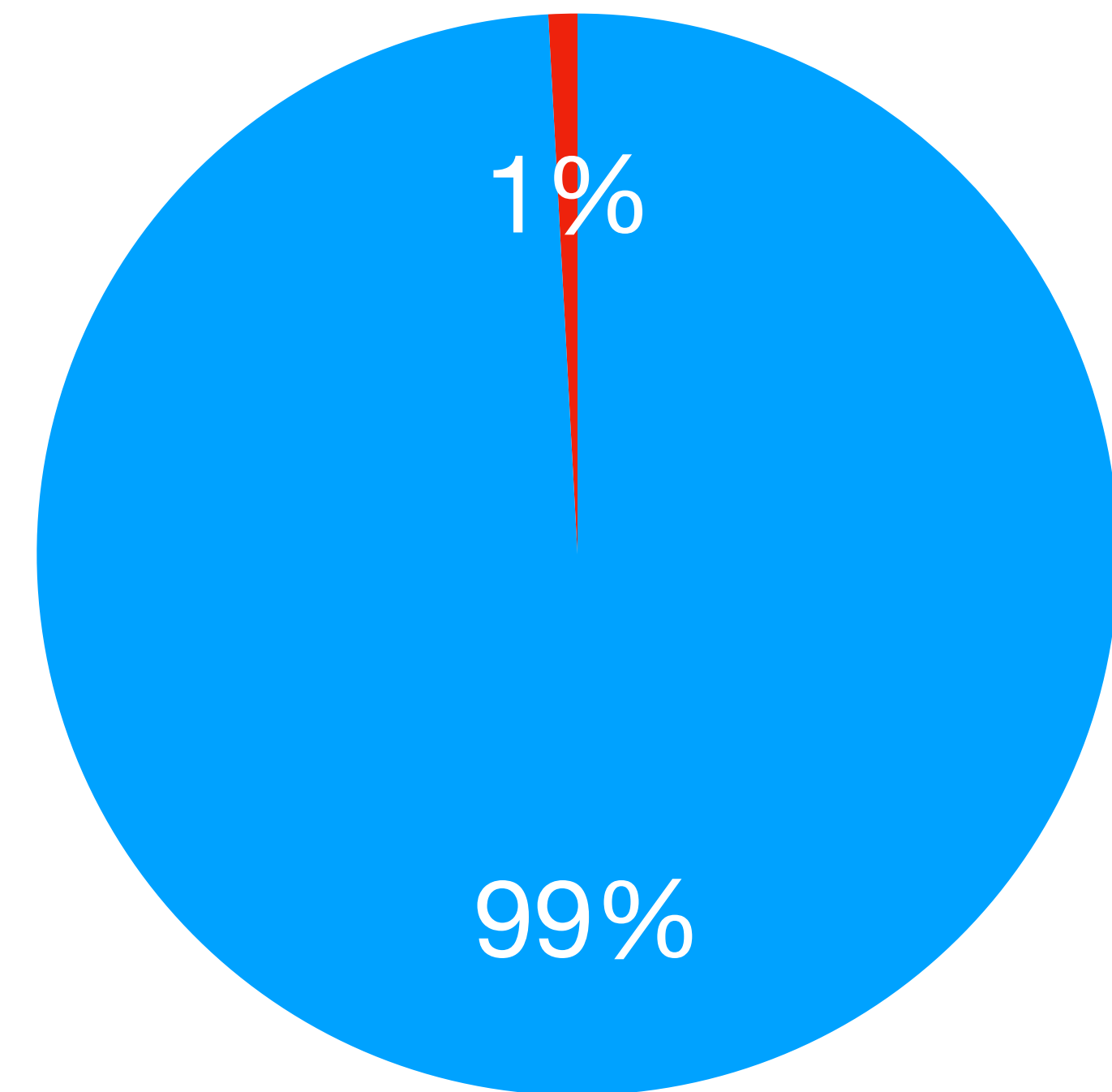



# What I Want

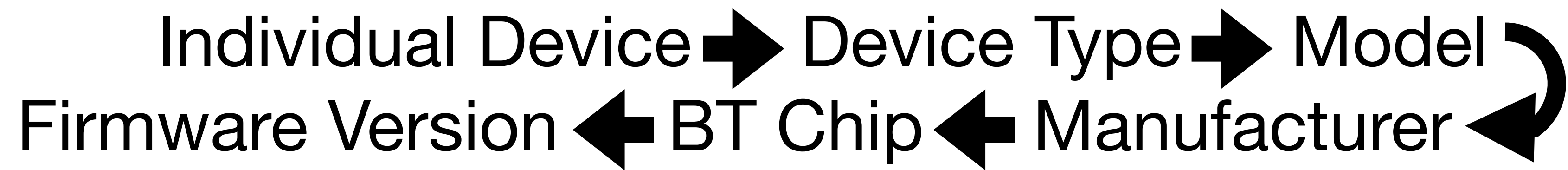





# What I Want

Name = "Ace2"

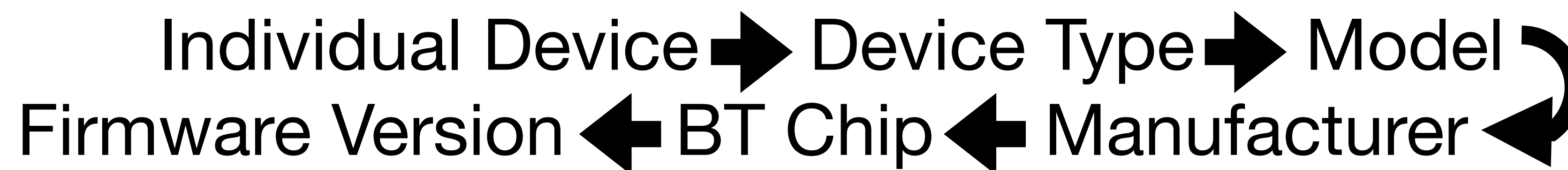



# What I Want

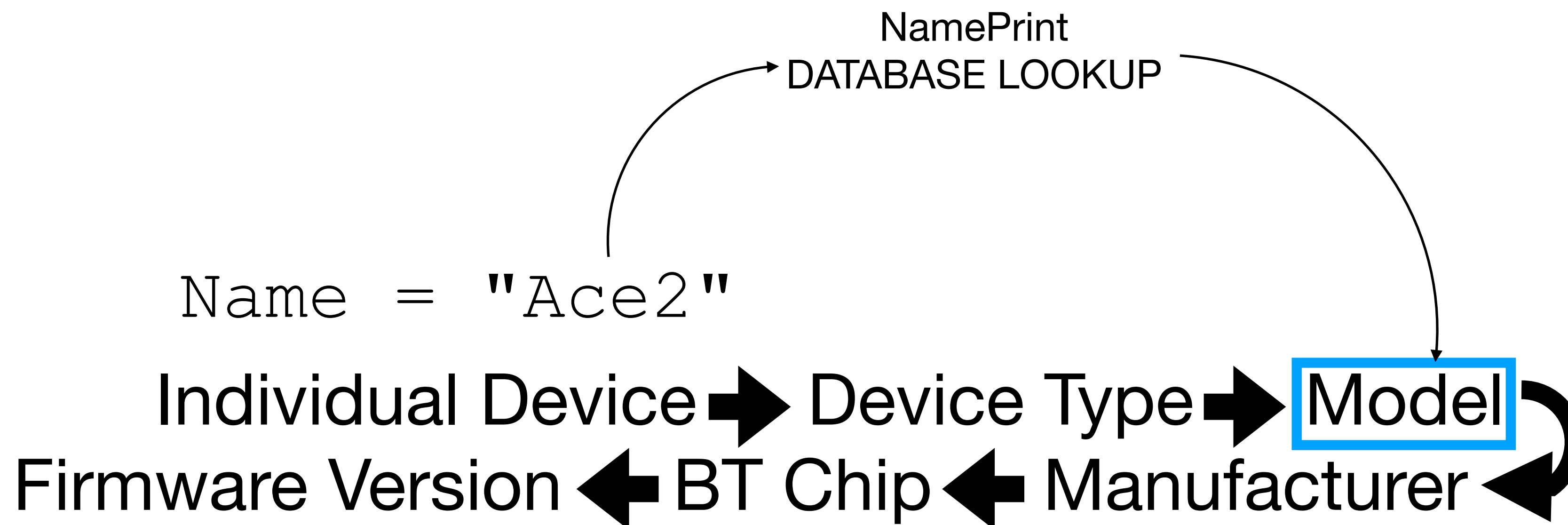



# What I Want

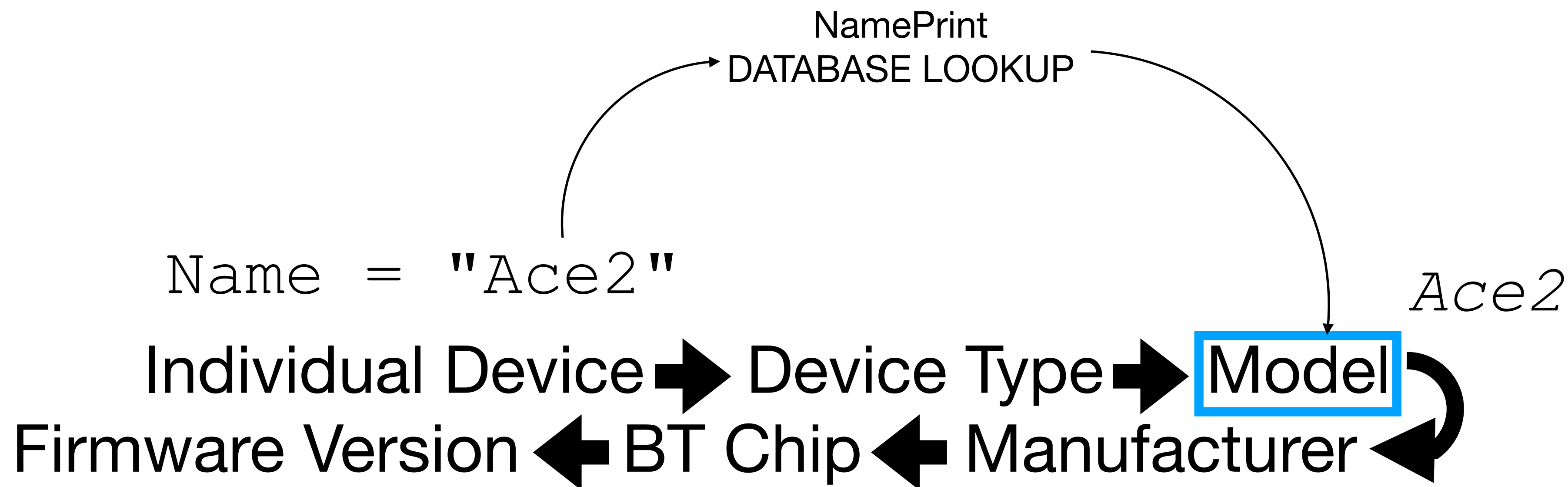



# What I Want

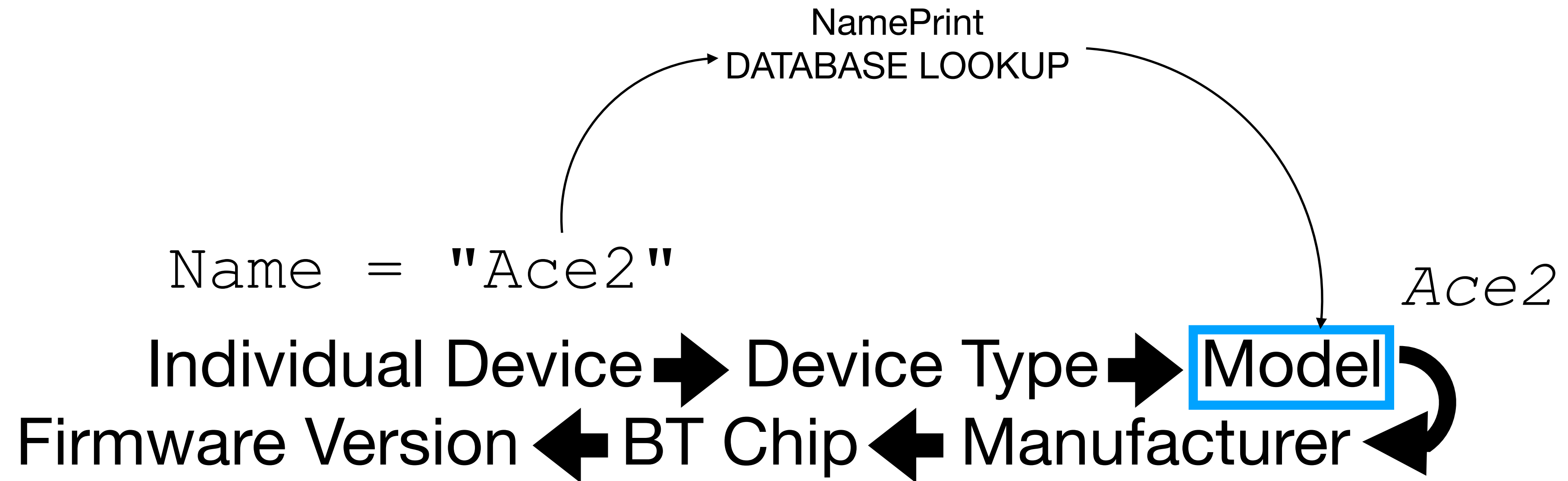

## ASSUMPTION:

Identifying a Model also allows  
the identification of the Manufacturer & Device Type



# What I Want

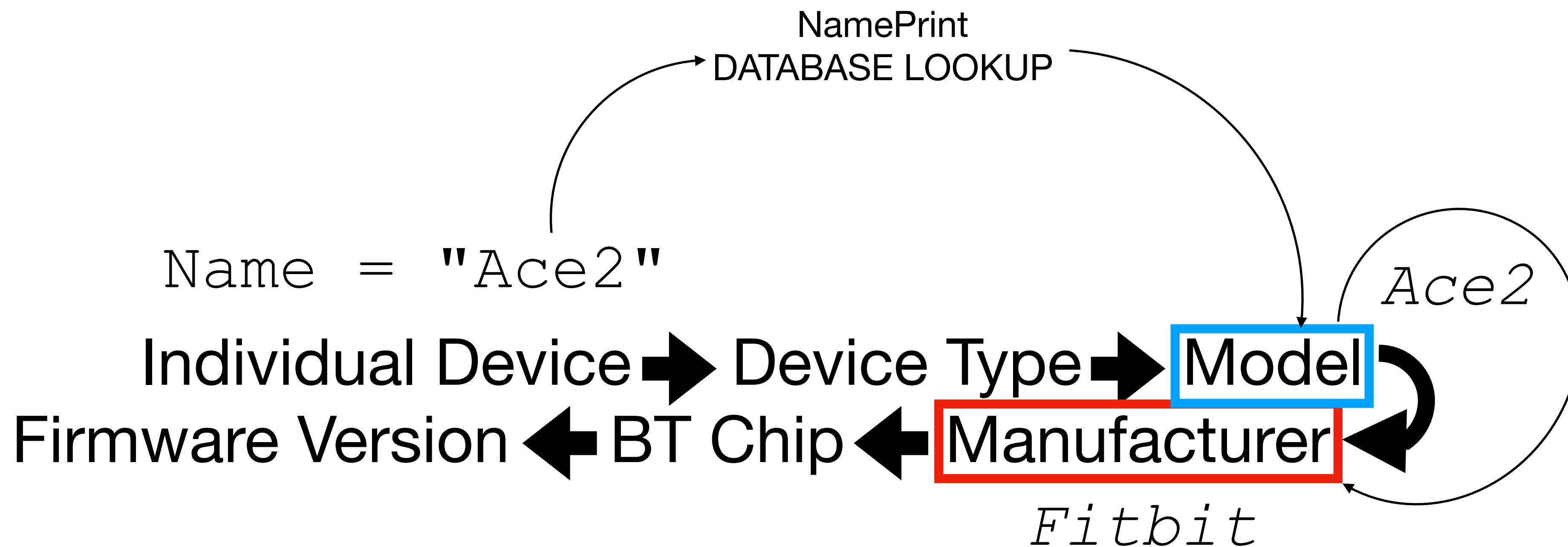

## ASSUMPTION:

Identifying a Model also allows  
the identification of the Manufacturer & Device Type



# What I Want

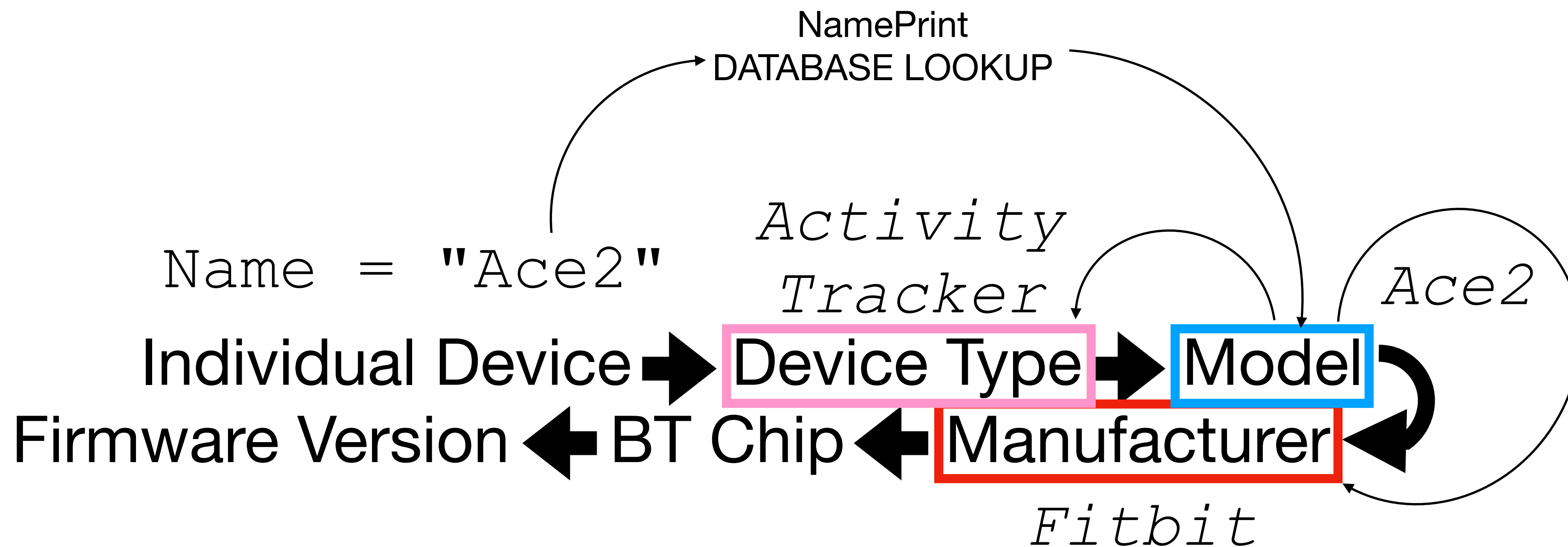

## ASSUMPTION:

Identifying a Model also allows the identification of the Manufacturer & Device Type



# Occasionally NamePrint -> ChipPrint

- *Very rarely (as in, I've only seen this once so far ;)),* the vendor will make a big deal out of what chip it uses, and then you can quickly get a ChipPrint directly from the NamePrint!
- NamePrint="^FiiO BTR5\$",ChipPrint="CSR8675"



# BTR5

## Flagship Portable High-Fidelity Bluetooth Amplifier

High Performance DAC ES9218P\*2

Flagship Bluetooth chip CSR8675

FPGA clock management, dual independent crystal oscillators

Bluetooth 5.0 with full format support

Independent control chip XMOS XUF208

USB DAC supporting up to 384kHz/DSD256 native

Double-sided 2.5D glass with OLED display

3.5mm+2.5mm headphone outputs

Intelligent control with FiiO Music app

One-touch NFC pairing



受賞



受賞

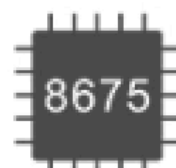
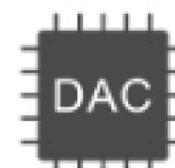





# BTR5

## Flagship Portable High-Fidelity Bluetooth Amplifier

High Performance DAC ES9218P\*2

Flagship Bluetooth chip CSR8675

FPGA clock management, dual independent crystal oscillators

Bluetooth 5.0 with full format support

Independent control chip XMOS XUF208

USB DAC supporting up to 384kHz/DSD256 native

Double-sided 2.5D glass with OLED display

3.5mm+2.5mm headphone outputs

Intelligent control with FiiO Music app

One-touch NFC pairing



受賞



受賞

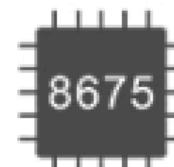
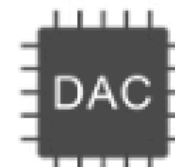

# 2thprint by Device ID Profile





# BTC EIR Device ID

- Some devices seem to include Device ID information as shown here in BTC Extended Inquiry Response packets
- Despite the fact that I can't find anything in the spec saying that's supposed to be a thing? (The "Supplement to the Bluetooth Core Specification" doesn't list it as valid...)
- If VendorIDSource = 1, the VendorID is looked up in the Bluetooth assigned company IDs. If it's 2, it's looked up in the USB assigned company IDs

## 5.1.10 Device Identification Profile (DID)

Applicable to Service Class UUIDs:

- PnPInformation: 0x1200

Last Modified: 2023-02-02

Attribute ID	Attribute Name
0x0200	SpecificationID
0x0201	VendorID
0x0202	ProductID
0x0203	Version
0x0204	PrimaryRecord
0x0205	VendorIDSource



# BTC EIR Device ID

- Some devices seem to include Device ID information as shown here in BTC Extended Inquiry Response packets
  - Despite the fact that I can't find anything in the spec saying that's supposed to be a thing? (The "Supplement to the Bluetooth Core Specification" doesn't list it as valid...)
- If VendorIDSource = 1, the VendorID is looked up in the Bluetooth assigned company IDs. If it's 2, it's looked up in the USB assigned company IDs

```
Extended Inquiry Response Data
  Device Name: SD-7000T_96
    Length: 12
    Type: Device Name (0x09)
    Device Name: SD-7000T_96
  Tx Power Level
    Length: 2
    Type: Tx Power Level (0x0a)
    Power Level (dBm): 6
  Device ID / Security Manager TK Value
    Length: 9
    Type: Device ID / Security Manager TK Value (0x10)
    Vendor ID Source: USB Implementer's Forum (0x0002)
    Vendor ID: Linux Foundation (0x1d6b)
    Product ID: 0x0246 (Unknown)
    Version: 0x053c
```

Last Modified: 2023-02-02

Attribute ID	Attribute Name
0x0200	SpecificationID
0x0201	VendorID
0x0202	ProductID
0x0203	Version
0x0204	PrimaryRecord
0x0205	VendorIDSource



Product: SD-7000T1  
User Manual



# BTC EIR Device ID

- Some devices seem to include Device ID information as shown here in BTC Extended Inquiry Response packets
- Despite the fact that I can't find anything in the spec saying that's supposed to be a thing? (The "Supplement to the Bluetooth Core Specification" doesn't list it as valid...)
- If VendorIDSource = 1, the VendorID is looked up in the Bluetooth assigned company IDs. If it's 2, it's looked up in the USB assigned company IDs

```

Extended Inquiry Response Data
  Device Name: SD-7000T_96
    Length: 12
    Type: Device Name (0x09)
    Device Name: SD-7000T_96
  Tx Power Level
    Length: 2
    Type: Tx Power Level (0x0a)
    Power Level (dBm): 6
  Device ID / Security Manager TK Value
    Length: 9
    Type: Device ID / Security Manager TK Value (0x10)
    Vendor ID Source: USB Implementer's Forum (0x0002)
    Vendor ID: Linux Foundation (0x1d6b)
    Product ID: 0x0246 (Unknown)
    Version: 0x053c
  
```

Last Modified: 2023-02-02

Attribute ID	Attribute Name
0x0200	SpecificationID
0x0201	VendorID
0x0202	ProductID
0x0203	Version
0x0204	PrimaryRecord
0x0205	VendorIDSource



# Top 20 Vendors for BTC Device ID data

## BTC - 2023-10-26

vendor_source	vendor_id_hex	company_name	frequency
Bluetooth	0x4E8	STABILO International	4462
USB	0x1D6B	Linux Foundation	433
Bluetooth	0x0	Ericsson AB	95
USB	0x44E	Alps Electric Co., Ltd	85
Bluetooth	0xA	Qualcomm Technologies International, Ltd. (QTIL)	62
Bluetooth	0x75	Samsung Electronics Co. Ltd.	60
USB	0xA12	Cambridge Silicon Radio, Ltd	58
Bluetooth	0x4C	Apple, Inc.	23
Bluetooth	0x3E0	Actions (Zhuhai) Technology Co., Limited	21
USB	0x108C	Robert Bosch GmbH	16
992	0xFFFF	NULL	15
Bluetooth	0x9E	Bose Corporation	12
Bluetooth	0x474C	NULL	12
USB	0x54C	Sony Corp.	5
Bluetooth	0x850	Yealink (Xiamen) Network Technology Co.,LTD	5
256	0x4E8	NULL	5
USB	0xA9	NULL	4
Bluetooth	0x418	Reserved	4
USB	0xA	NULL	4
Bluetooth	0x103	Bang & Olufsen A/S	4

<- actually Samsung





# Top 20 Vendors for BTC Device ID data

BTC - 2023-10-26

Samsung's setting their vendor source to Bluetooth but then using their USB ID



vendor_source	vendor_id_hex	company_name	frequency
Bluetooth	0x4E8	STABILO International	4462
USB	0x1D6B	Linux Foundation	433
Bluetooth	0x0	Ericsson AB	95
USB	0x44E	Alps Electric Co., Ltd	85
Bluetooth	0xA	Qualcomm Technologies International, Ltd. (QTIL)	62
Bluetooth	0x75	Samsung Electronics Co. Ltd.	60
USB	0xA12	Cambridge Silicon Radio, Ltd	58
Bluetooth	0x4C	Apple, Inc.	23
Bluetooth	0x3E0	Actions (Zhuhai) Technology Co., Limited	21
USB	0x108C	Robert Bosch GmbH	16
992	0xFFFF	NULL	15
Bluetooth	0x9E	Bose Corporation	12
Bluetooth	0x474C	NULL	12
USB	0x54C	Sony Corp.	5
Bluetooth	0x850	Yealink (Xiamen) Network Technology Co.,LTD	5
256	0x4E8	NULL	5
USB	0xA9	NULL	4
Bluetooth	0x418	Reserved	4
USB	0xA	NULL	4
Bluetooth	0x103	Bang & Olufsen A/S	4

<- actually Samsung





- This snippet from the 4.0 spec (before they started using the Core Spec Supplement) suggests that Device ID profile information can be included in EIR

## 8.1 EIR DATA TYPE DEFINITIONS

This section defines the basic EIR data types. Additional EIR data types may be defined in profile specifications.

- Basically all the other data types made their way into the CSS but not this...

### 7 EIR Transactions to Obtain Device ID Information

If Extended Inquiry Response is supported by a given device that supports the Device ID Profile, then the device may expose the Device ID information in the Extended Inquiry Response when discoverable.

If an implementer chooses to expose a Device ID EIR record, the following Device ID attribute values shall be exposed:

Attribute	Attribute Value Type
VendorIDSource	Uint16
VendorID	Uint16
ProductID	Uint16
Version	Uint16

See section 8.2 for details on the format of the Device ID EIR Record.

From Device Identification Profile 1.3

### 8.2 Device ID Extended Inquiry Response

The inclusion of the Device ID EIR Record is optional. However, for each Device ID EIR Record that is included in the EIR record, a corresponding Device ID Service Record (meaning that all attributes that appear in both the Service Record and the EIR Record shall be equal) shall be included in the SDP database. The format of the Device ID EIR Record shall be as shown in Table 8.2.

Value	Notes
0x09	Length of this Data
0xTT	Device ID EIR Tag
0xYYYY	Uint16 Vendor ID Source
0xYYYY	Uint16 VendorID
0xYYYY	Uint16 ProductID
0xYYYY	Uint16 Version

Table 8.2: Device ID Extended Inquiry Response Tags

From Device Identification Profile 1.3





- From assigned numbers doc

Common Data Type	Name	Reference
0x01	Flags	Core Specification Supplement, Part A, Section 1.3
0x02	Incomplete List of 16-bit Service Class UUIDs	Core Specification Supplement, Part A, Section 1.1
0x03	Complete List of 16-bit Service Class UUIDs	Core Specification Supplement, Part A, Section 1.1
0x04	Incomplete List of 32-bit Service Class UUIDs	Core Specification Supplement, Part A, Section 1.1
0x05	Complete List of 32-bit Service Class UUIDs	Core Specification Supplement, Part A, Section 1.1
0x06	Incomplete List of 128-bit Service Class UUIDs	Core Specification Supplement, Part A, Section 1.1
0x07	Complete List of 128-bit Service Class UUIDs	Core Specification Supplement, Part A, Section 1.1
0x08	Shortened Local Name	Core Specification Supplement, Part A, Section 1.2
0x09	Complete Local Name	Core Specification Supplement, Part A, Section 1.2
0x0A	Tx Power Level	Core Specification Supplement, Part A, Section 1.5
0x0D	Class of Device	Core Specification Supplement, Part A, Section 1.6
0x0E	Simple Pairing Hash C-192	Core Specification Supplement, Part A, Section 1.6
0x0F	Simple Pairing Randomizer R-192	Core Specification Supplement, Part A, Section 1.6
0x10	Device ID	Device ID Profile
0x10	Security Manager TK Value	Core Specification Supplement, Part A, Section 1.8
0x11	Security Manager Out of Band Flags	Core Specification Supplement, Part A, Section 1.7
0x12	Peripheral Connection Interval Range	Core Specification Supplement, Part A, Section 1.9



- From assigned numbers doc

Common Data Type	Name	Reference
0x01	Flags	Core Specification Supplement, Part A, Section 1.3
0x02	Incomplete List of 16-bit Service Class UUIDs	Core Specification Supplement, Part A, Section 1.1
0x03	Complete List of 16-bit Service Class UUIDs	Core Specification Supplement, Part A, Section 1.1
0x04	Incomplete List of 32-bit Service Class UUIDs	Core Specification Supplement, Part A, Section 1.1
0x05	Complete List of 32-bit Service Class UUIDs	Core Specification Supplement, Part A, Section 1.1
0x06	Incomplete List of 128-bit Service Class UUIDs	Core Specification Supplement, Part A, Section 1.1
0x07	Complete List of 128-bit Service Class UUIDs	Core Specification Supplement, Part A, Section 1.1
0x08	Shortened Local Name	Core Specification Supplement, Part A, Section 1.2
0x09	Complete Local Name	Core Specification Supplement, Part A, Section 1.2
0x0A	Tx Power Level	Core Specification Supplement, Part A, Section 1.5
0x0D	Class of Device	Core Specification Supplement, Part A, Section 1.6
0x0E	Simple Pairing Hash C-192	Core Specification Supplement, Part A, Section 1.6
0x0F	Simple Pairing Randomizer R-192	Core Specification Supplement, Part A, Section 1.6
0x10	Device ID	Device ID Profile
0x10	Security Manager TK Value	Core Specification Supplement, Part A, Section 1.8
0x11	Security Manager Out of Band Flags	Core Specification Supplement, Part A, Section 1.7
0x12	Peripheral Connection Interval Range	Core Specification Supplement, Part A, Section 1.9

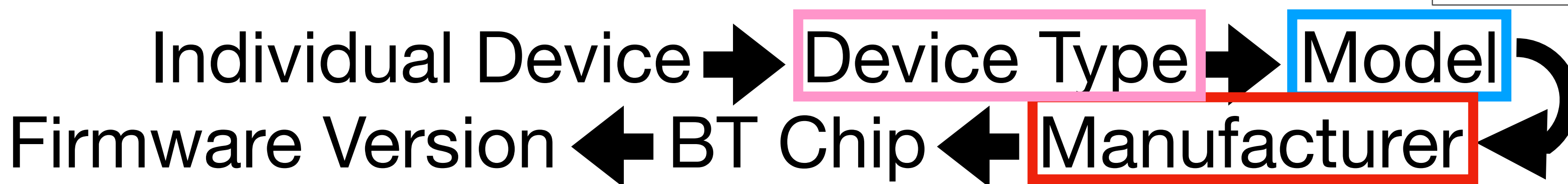



- From assigned numbers doc

Common Data Type	Name	Reference
0x01	Flags	Core Specification Supplement, Part A, Section 1.3
0x02	Incomplete List of 16-bit Service Class UUIDs	Core Specification Supplement, Part A, Section 1.1
0x03	Complete List of 16-bit Service Class UUIDs	Core Specification Supplement, Part A, Section 1.1
0x04	Incomplete List of 32-bit Service Class UUIDs	Core Specification Supplement, Part A, Section 1.1
0x05	Complete List of 32-bit Service Class UUIDs	Core Specification Supplement, Part A, Section 1.1
0x06	Incomplete List of 128-bit Service Class UUIDs	Core Specification Supplement, Part A, Section 1.1
0x07	Complete List of 128-bit Service Class UUIDs	Core Specification Supplement, Part A, Section 1.1
0x08	Shortened Local Name	Core Specification Supplement, Part A, Section 1.2
0x09	Complete Local Name	Core Specification Supplement, Part A, Section 1.2
0x0A	Tx Power Level	Core Specification Supplement, Part A, Section 1.5
0x0D	Class of Device	Core Specification Supplement, Part A, Section 1.6
0x0E	Simple Pairing Hash C-192	Core Specification Supplement, Part A, Section 1.6
0x0F	Simple Pairing Randomizer R-192	Core Specification Supplement, Part A, Section 1.6
0x10	Device ID	Device ID Profile
0x10	Security Manager TK Value	Core Specification Supplement, Part A, Section 1.8
0x11	Security Manager Out of Band Flags	Core Specification Supplement, Part A, Section 1.7
0x12	Peripheral Connection Interval Range	Core Specification Supplement, Part A, Section 1.9

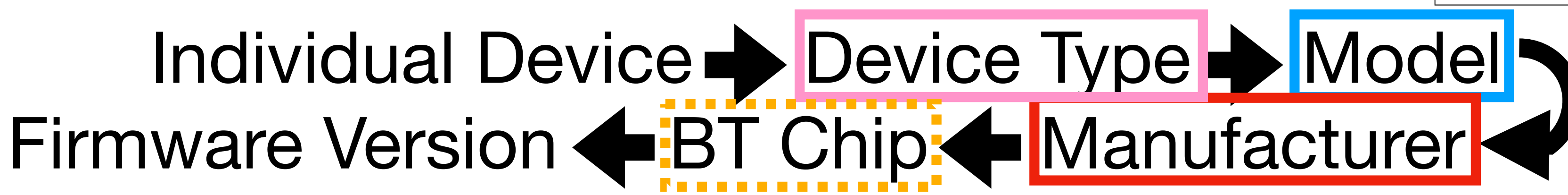

**2thprint by UUID16**



**or**





# 2thprint by UUID16

## UUID16Print

- 16-bit UUIDs can be optionally included in BTC EIR packets or BLE Advertisements
- They are frequently used to advertise company-specific services (usually served over GATT)
- Silicon vendors are present, but not prevalent

```
./TellMeEverything.py --UUID16stats=quiet
----= BLUETOOTH CLASSIC RESULTS =----
count  uuid16  company
X 254    0xfe4c   Volkswagen AG
X 57     0xfe31   Volkswagen AG
X 31     0xfe35   HUAWEI Technologies Co., Ltd
X 24     0xfdd1   Huawei Technologies Co., Ltd
🍪 12     0xfd69   Samsung Electronics Co., Ltd
X 1      0xfeea   Swirl Networks, Inc.

----= BLUETOOTH LOW ENERGY RESULTS =----
count  uuid16  company
X 109258 0xfef3   Google LLC
🍪 108953 0xfd6f   Apple, Inc.
🍪 44895  0xfd69   Samsung Electronics Co., Ltd
X 29877  0xfeed   Tile, Inc.
X 29059  0xfebe   Bose Corporation
X 13392  0xfeaa   Google LLC
X 13184  0xfe9f   Google LLC
X 12533  0xfe03   Amazon.com Services, Inc.
X 9450   0xfd5a   Samsung Electronics Co., Ltd.
X 8922   0xfe50   Google LLC
X 6642   0xfe1f   Garmin International, Inc.
X 5107   0xfe2c   Google LLC
X 4686   0xfe61   Logitech International SA
X 3903   0xfe4c   Volkswagen AG
X 3801   0xfe26   Google LLC
X 2663   0xfea0   Google LLC
X 2451   0xfd82   Sony Corporation
X 2420   0xfe78   Hewlett-Packard Company
X 2353   0fee7    Tencent Holdings Limited.
X 2018   0xfe48   General Motors
...
```





# What I Want

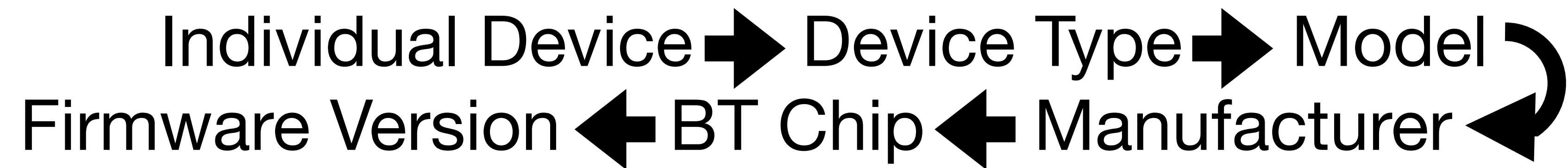



# What I Want

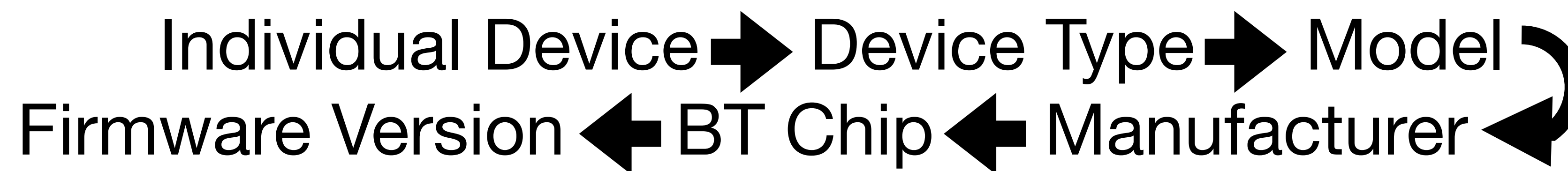

UUID16: **0xfeF1**





# What I Want

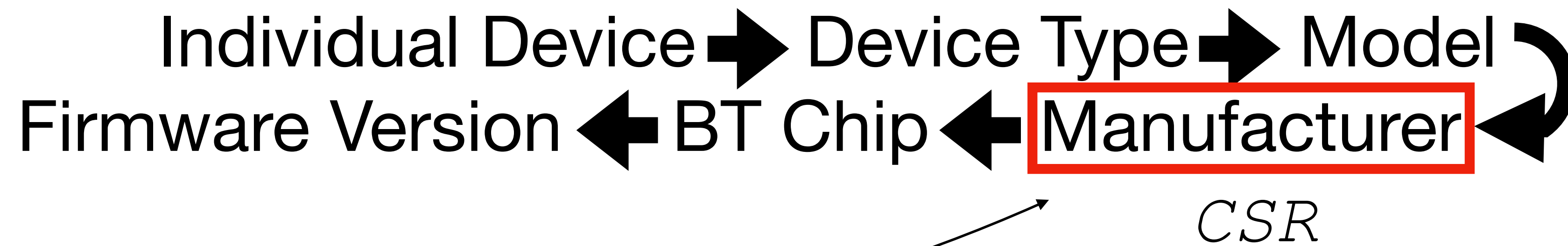

UUID16Print  
DATABASE LOOKUP →

UUID16: **0xfeF1**



# What I Want

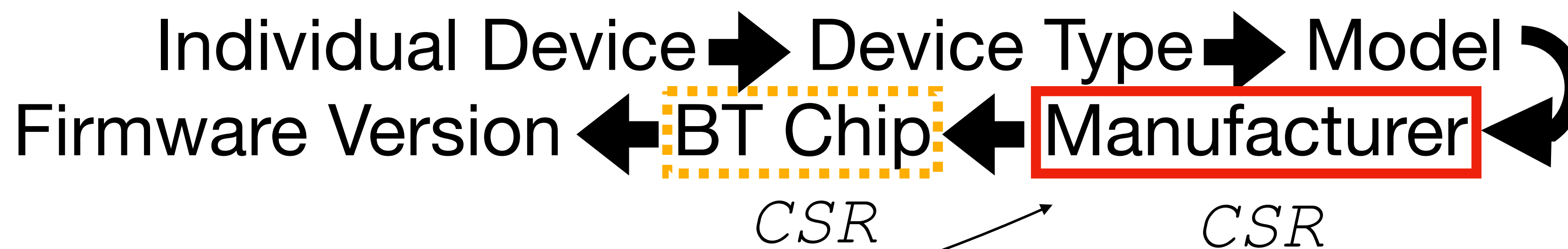

UUID16Print  
DATABASE LOOKUP →

UUID16: **0xfeF1**



# What I Want

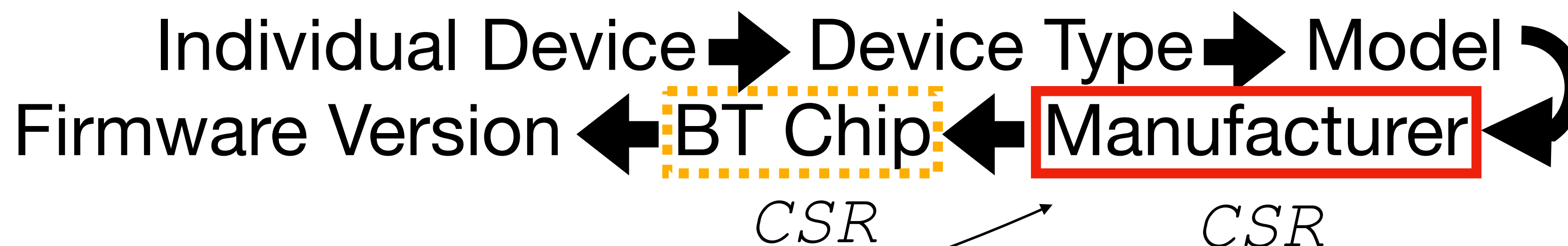

UUID16Print  
DATABASE LOOKUP →

UUID16: **0xfeF1**

## ASSUMPTION:

UUID16Prints are just the assigned values from the BT  
public/assigned\_numbers/uuids/member\_uuids.yaml

**2thprint by UUID128**



**or**





# 2thprint by UUID128

## UUID128Print

- Detective Work : UUID128Print -> NamePrint



# KFTC BANKPOS

## Point of Sale terminal

- Regex: `^KFTC BANKPOS$`
- "Korea Financial Telecommunications and Clearings Institute (Korean: 금융결제원, KFTC) is a non-profit organization which manages several inter-bank payment systems in South Korea."
- [https://en.wikipedia.org/wiki/Korea\\_Financial\\_Telecommunications\\_%26\\_Clearings\\_Institute](https://en.wikipedia.org/wiki/Korea_Financial_Telecommunications_%26_Clearings_Institute)



# KFTC BANKPOS

## Point of Sale terminal

- Regex: `^KFTC BANKPOS$`
- "Korea Financial Telecommunications and Clearings Institute (Korean: 금융결제원, KFTC) is a non-profit organization which manages several inter-bank payment systems in South Korea."
- [https://en.wikipedia.org/wiki/Korea\\_Financial\\_Telecommunications\\_%26\\_Clearings\\_Institute](https://en.wikipedia.org/wiki/Korea_Financial_Telecommunications_%26_Clearings_Institute)

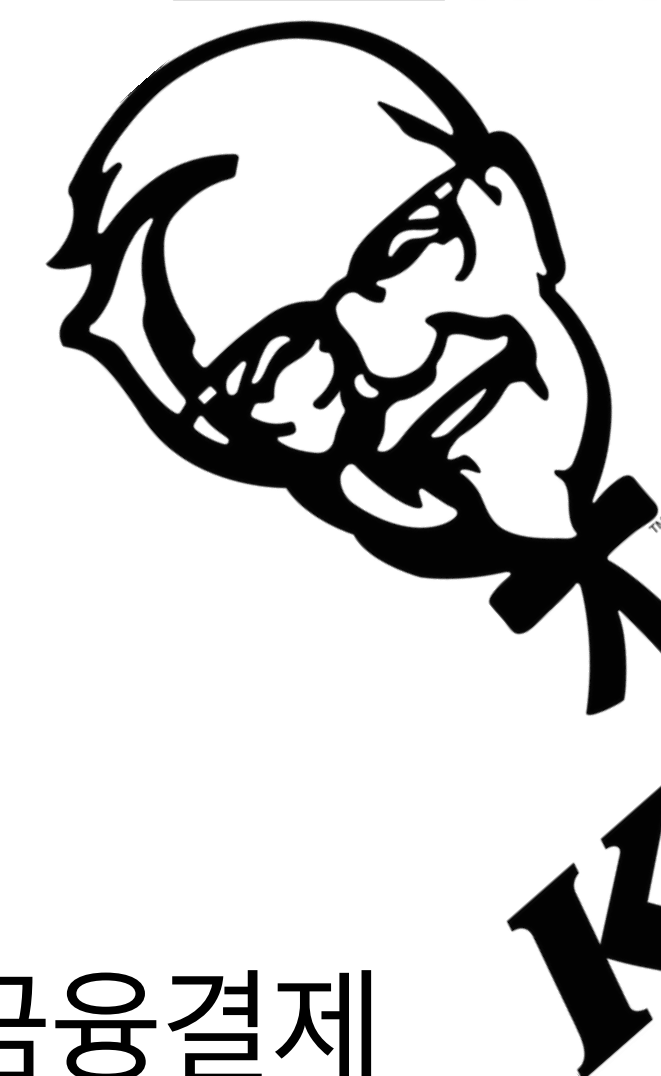



# KFTC BANKPOS

## Point of Sale terminal

```
For bdaddr = 04:32:f4:18:2e:d8:
  Company Name by IEEE OUI (04:32:f4): Partron

No BTC Extended Inquiry Result Device info.

DeviceName: KFTC BANKPOS
  In BT LE Data (LE_bdaddr_to_name), bdaddr_random = 0 (Public)
  This was found in an event of type 4 which corresponds to Scan Response (SCAN_RSP)

No UUID16s found.

No transmit power found.

No Appearance data found.

Manufacturer-specific Data:
  Device Company ID: 0x004c (Apple, Inc.) - take with a grain of salt, not all companies populate this accurately!
  Endianness-flipped device company ID (in case the vendor used the wrong endianness): 0x4c00 (No Match)
  Raw Data: 0215585cde931b0142cc9a1325009bedc65e00010002c5
  Apple iBeacon:
    UUID128: 585cde93-1b01-42cc-9a13-25009bedc65e
    Major ID: 0001
    Minor ID: 0002
    RSSI at 1 meter: -59dBm
  In BT LE Data (LE_bdaddr_to_mf_specific), bdaddr_random = 0 (Public)
  This was found in an event of type 0 which corresponds to Connectable Undirected Advertising (ADV_IND)
```





# KFTC BANKPOS

## Point of Sale terminal

```
For bdaddr = 04:32:f4:18:48:d7:  
  Company Name by IEEE OUI (04:32:f4): Partron  
  
No BTC Extended Inquiry Result Device info.  
  
No Names found.  
  
No UUID16s found.  
  
No transmit power found.  
  
No Appearance data found.  
  
Manufacturer-specific Data:  
  Device Company ID: 0x004c (Apple, Inc.) - take with a grain of salt, not all companies populate this accurately!  
    Endianness-flipped device company ID (in case the vendor used the wrong endianness): 0x4c00 (No Match)  
  Raw Data: 0215585cde931b0142cc9a1325009bedc65e00010002c5  
  Apple iBeacon:  
    UUID128: 585cde93-1b01-42cc-9a13-25009bedc65e  
    Major ID: 0001  
    Minor ID: 0002  
    RSSI at 1 meter: -59dBm  
    In BT LE Data (LE_bdaddr_to_mf_specific), bdaddr_random = 0 (Public)  
    This was found in an event of type 0 which corresponds to Connectable Undirected Advertising (ADV_IND)
```



# What I Want

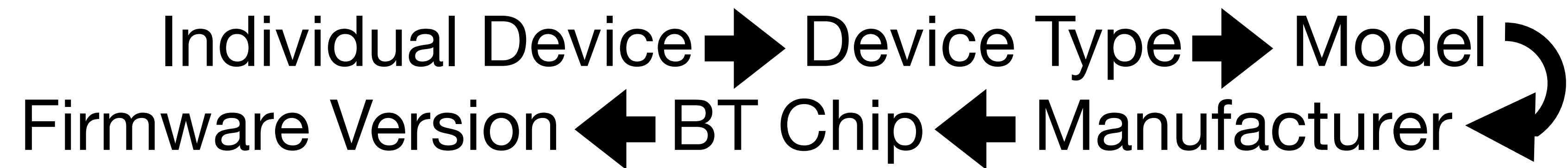



# What I Want

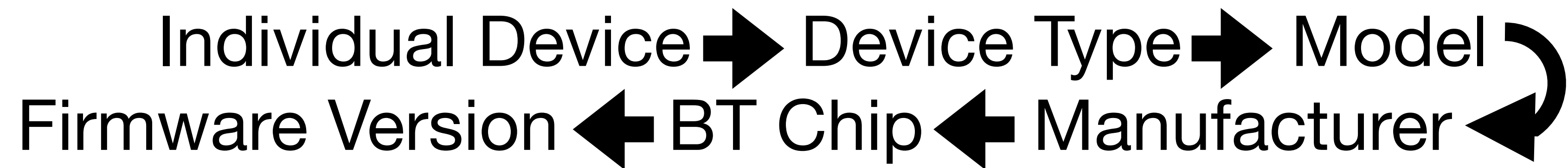

UUID128: **585cde93-1b01-42cc-9a13-25009bedc65e**



# What I Want

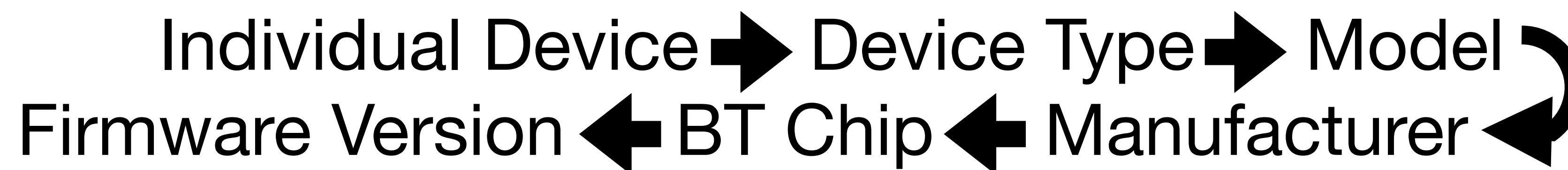

UUID128Print  
DATABASE LOOKUP

UUID128: **585cde93-1b01-42cc-9a13-25009bedc65e**



# What I Want

*"KFTC BANKPOS"*

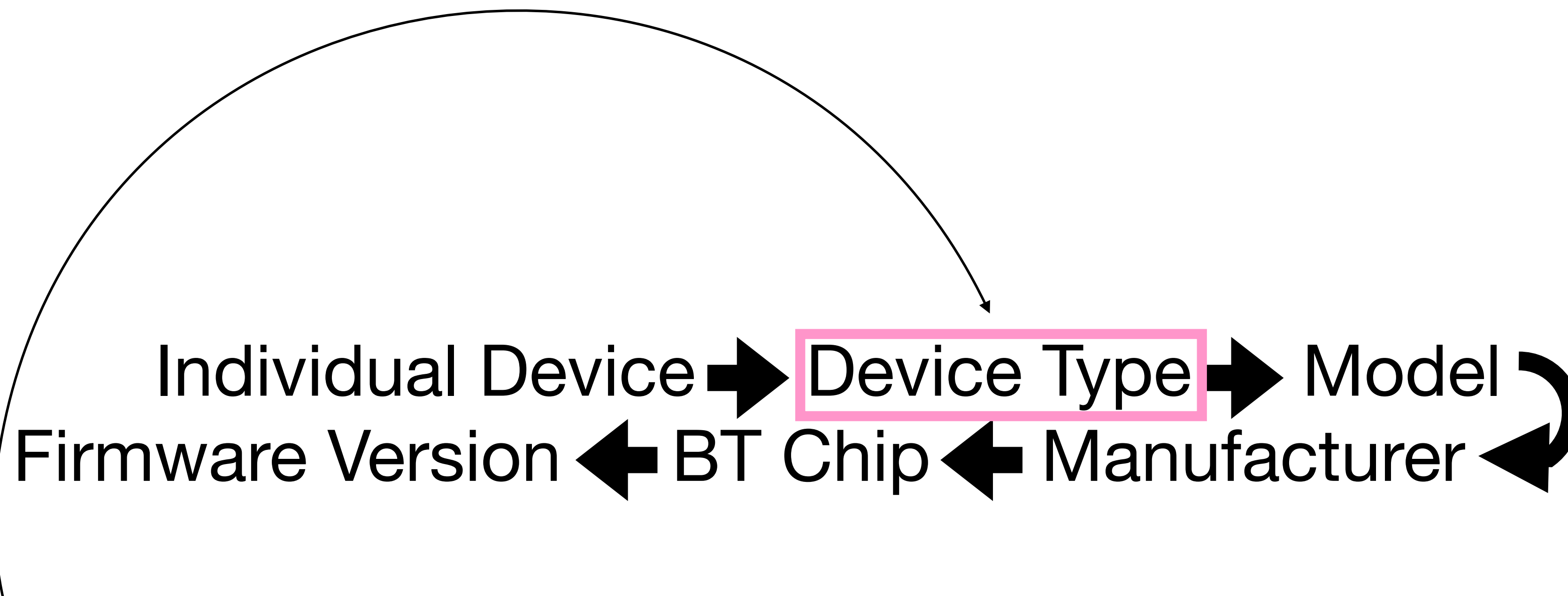

UUID128Print  
DATABASE LOOKUP

UUID128: **585cde93-1b01-42cc-9a13-25009bedc65e**



# What I Want

"KFTC BANKPOS"

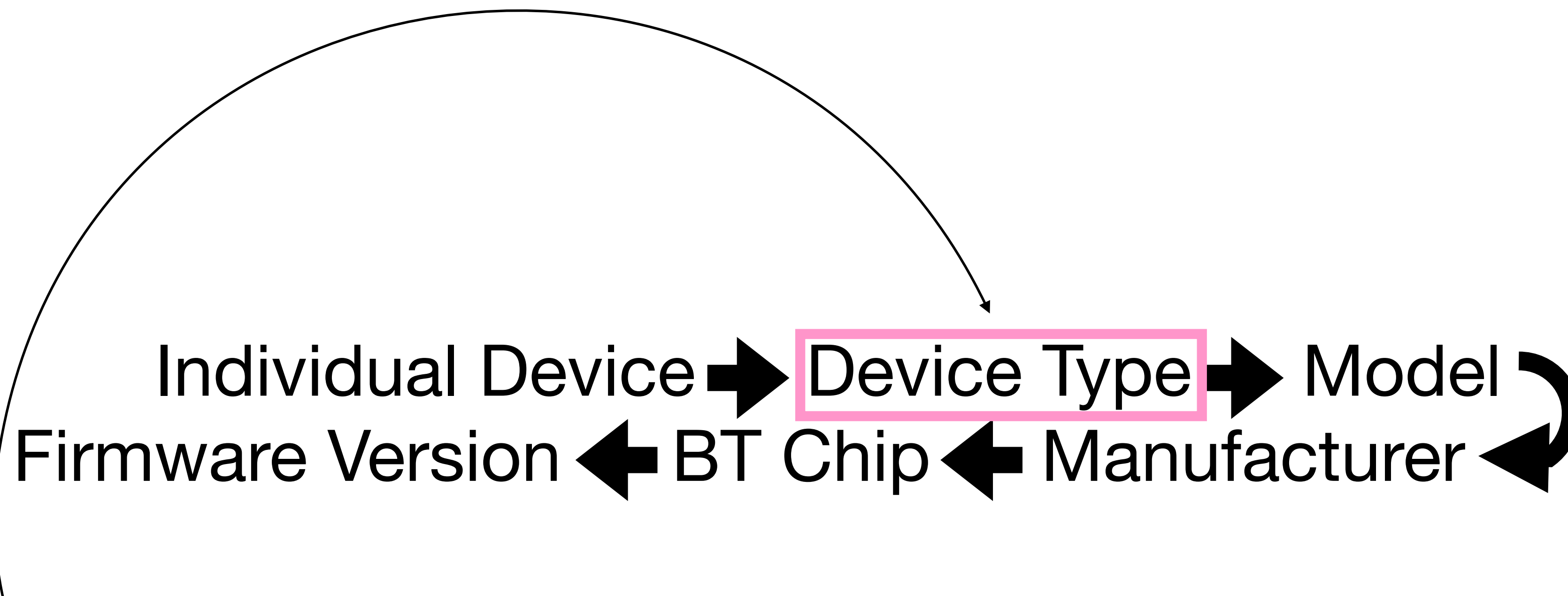

UUID128Print  
DATABASE LOOKUP

UUID128: **585cde93-1b01-42cc-9a13-25009bedc65e**

## ASSUMPTION:

UUID128Prints can be reused *within* Manufacturers,  
but not reused *between* Manufacturers



# Vendor-specific 128-bit UUIDs

- `abbaff00-e56a-484c-b832-8b17cf6cbfe8`
  - Versa (|2|Lite), Ionic
- `adabfb00-6e7d-4601-bda2-bffaa68956ba`
  - Inspire HR, Flex 2
- `adab0d57-6e7d-4601-bda2-bffaa68956ba`
- `adab6552-6e7d-4601-bda2-bffaa68956ba`
  - One
- `adab5b8c-6e7d-4601-bda2-bffaa68956ba`
  - Flex



# Vendor-specific 128-bit UUIDs

- `abbaff00-e56a-484c-b832-8b17cf6cbfe8`
  - Versa (|2|Lite), Ionic
- `adabfb00-6e7d-4601-bda2-bffaa68956ba`
  - Inspire HR, Flex 2
- `adab0d57-6e7d-4601-bda2-bffaa68956ba`
- `adab6552-6e7d-4601-bda2-bffaa68956ba`
  - One
- `adab5b8c-6e7d-4601-bda2-bffaa68956ba`
  - Flex

```
> HCI Event: LE Meta Event (0x3e) plen 42
  LE Advertising Report (0x02)
    Num reports: 1
    Event type: Connectable undirected - ADV_IND (0x00)
    Address type: Random (0x01)
    Address: F5:6E:B2:C3:73:D2 (Static)
    Data length: 30
    Flags: 0x06
      LE General Discoverable Mode
      BR/EDR Not Supported
    128-bit Service UUIDs (partial): 1 entry
      Vendor specific (abbaff00-e56a-484c-b832-8b17cf6cbfe8)
    Service Data (UUID 0x180a): 2604329303
    RSSI: -93 dBm (0xa3)
```



# Vendor-specific 128-bit UUIDs

- `abbaff00-e56a-484c-b832-8b17cf6cbfe8`
  - Versa (|2|Lite), Ionic
- `adabfb00-6e7d-4601-bda2-bffaa68956ba`
  - Inspire HR, Flex 2
- `adab0d57-6e7d-4601-bda2-bffaa68956ba`
- `adab6552-6e7d-4601-bda2-bffaa68956ba`
  - One
- `adab5b8c-6e7d-4601-bda2-bffaa68956ba`
  - Flex

> HCI Event: LE Meta Event (0x3e) plen 42  
LE Advertising Report (0x02)  
Num reports: 1  
Event type: Connectable undirected - **ADV\_IND** (0x00)  
Address type: Random (0x01)  
Address: F5:6E:B2:C3:73:D2 (Static)  
Data length: 30  
Flags: 0x06  
LE General Discoverable Mode  
BR/EDR Not Supported  
128-bit Service UUIDs (partial): 1 entry  
Vendor specific (**abbaff00-e56a-484c-b832-8b17cf6cbfe8**)  
Service Data (UUID 0x180a): 2604329303  
RSSI: -93 dBm (0xa3)



A device has no name



# What I Want

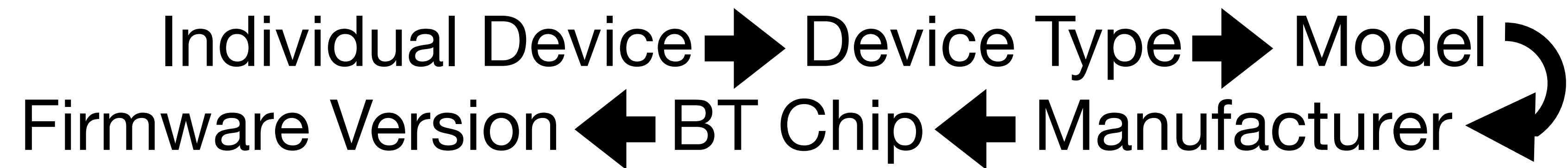



# What I Want

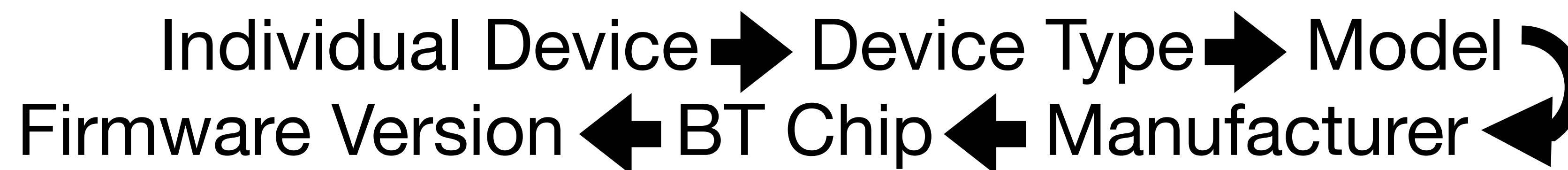

UUID128: **adabfb00-6e7d-4601-bda2-bffaa68956ba**



# What I Want

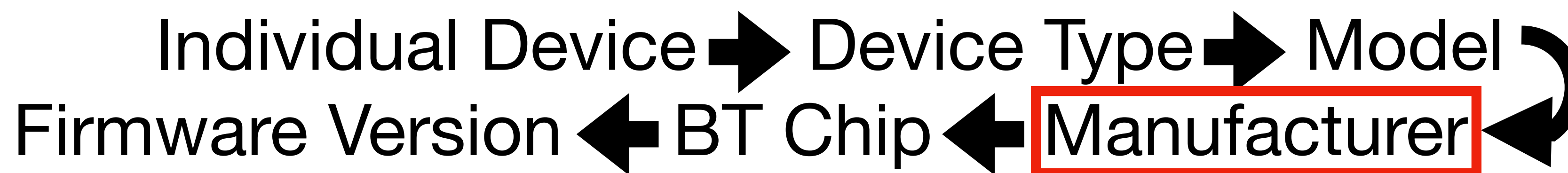

*Fitbit*

UUID128Print  
DATABASE LOOKUP

UUID128: **adabfb00-6e7d-4601-bda2-bffaa68956ba**



# What I Want

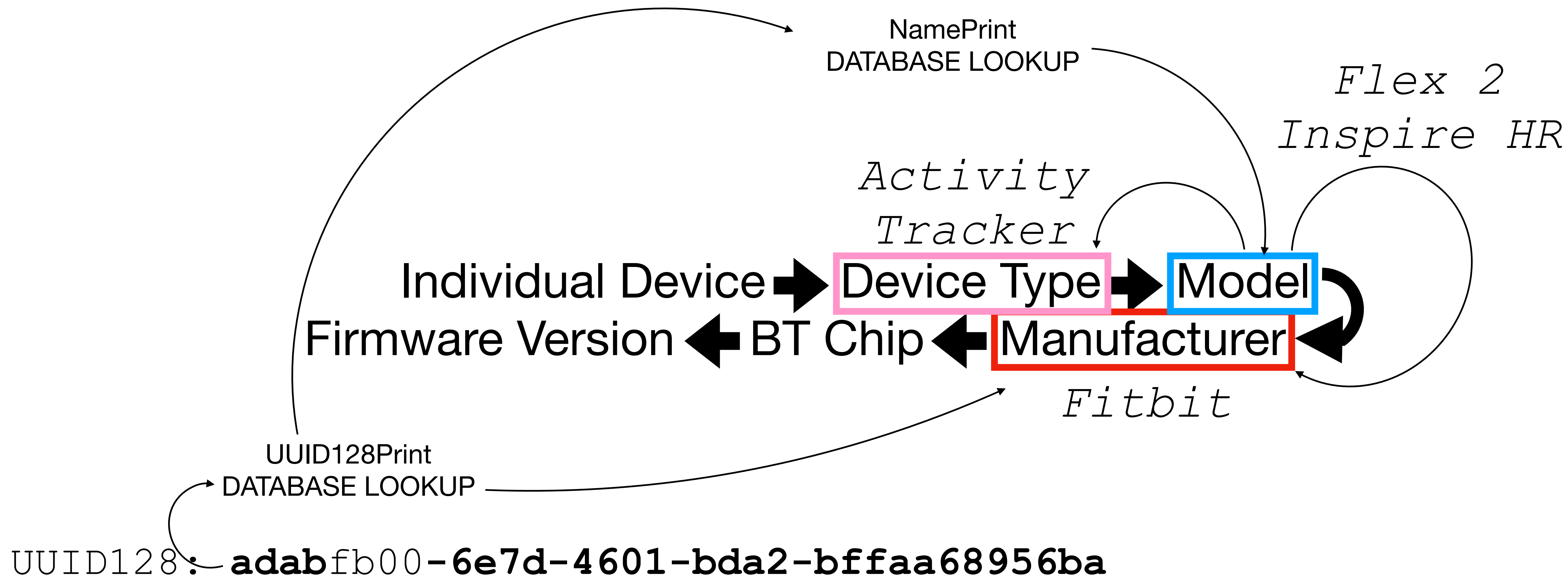



# What I Want

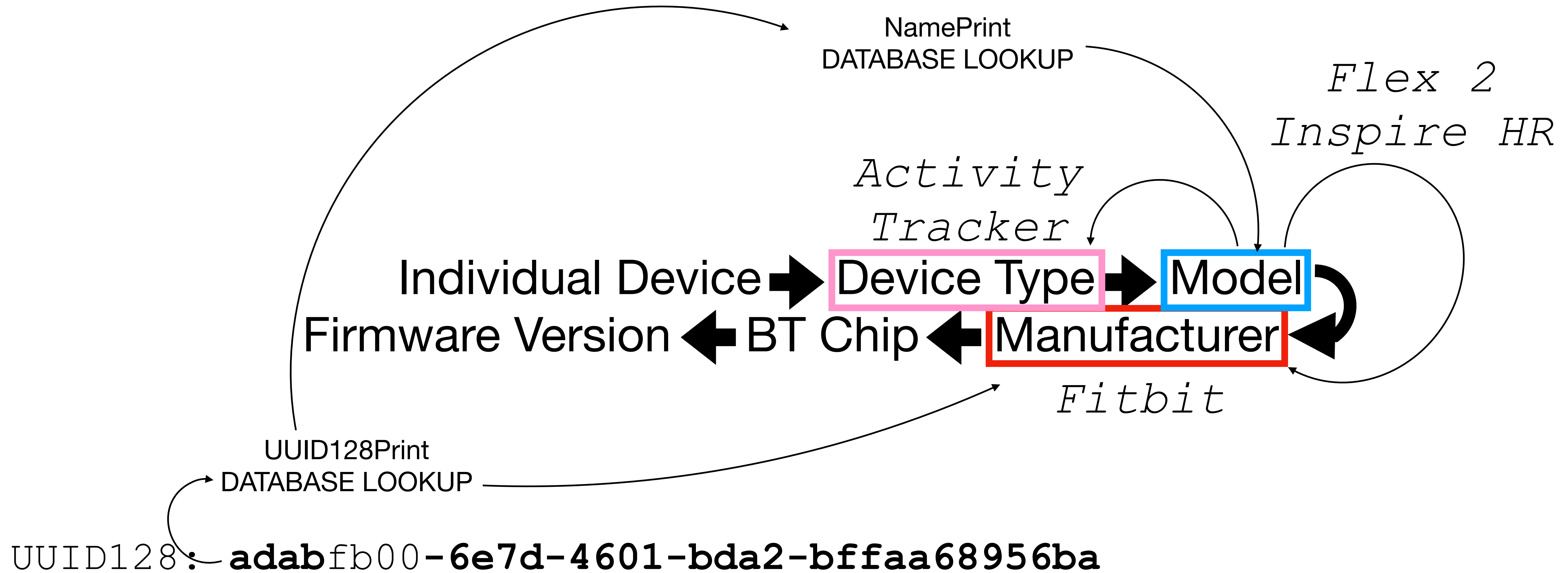

## ASSUMPTION:

UUID128Prints can be reused *within* Manufacturers, but not reused *between* Manufacturers



# What I Want

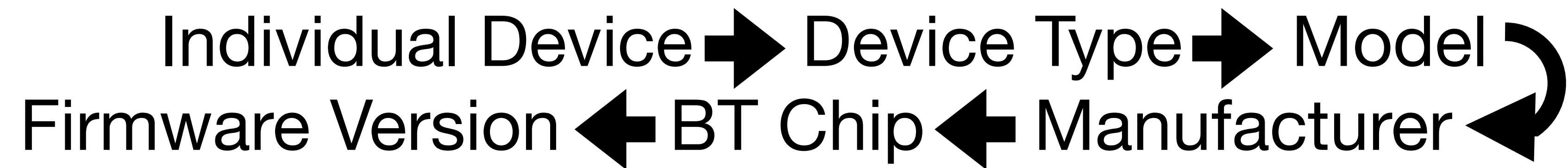



# What I Want

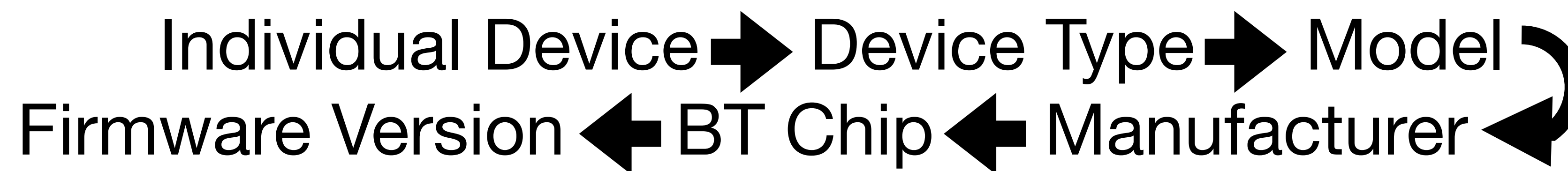

UUID128: 6e400001-b5a3-f393-e0a9-e50e24dcca9e





# What I Want

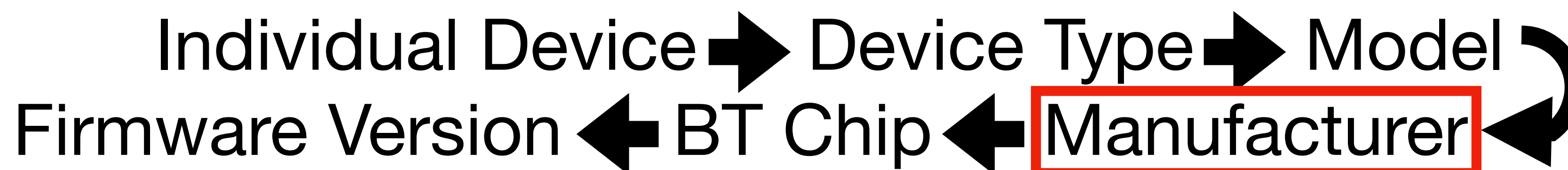

*Nordic*

UUID128Print  
DATABASE LOOKUP

UUID128: 6e400001-b5a3-f393-e0a9-e50e24dcca9e



# What I Want

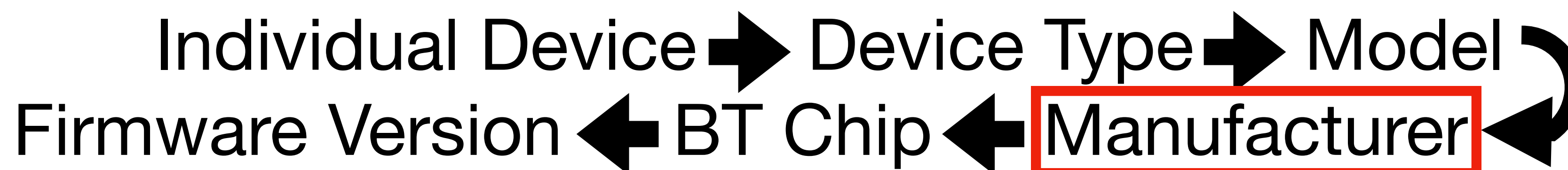

*Nordic*

UUID128Print  
DATABASE LOOKUP

UUID128: 6e400001-b5a3-f393-e0a9-e50e24dcca9e

## ASSUMPTION:

UUID128Prints can be reused *within* Manufacturers,  
but not reused *between* Manufacturers



# What I Want

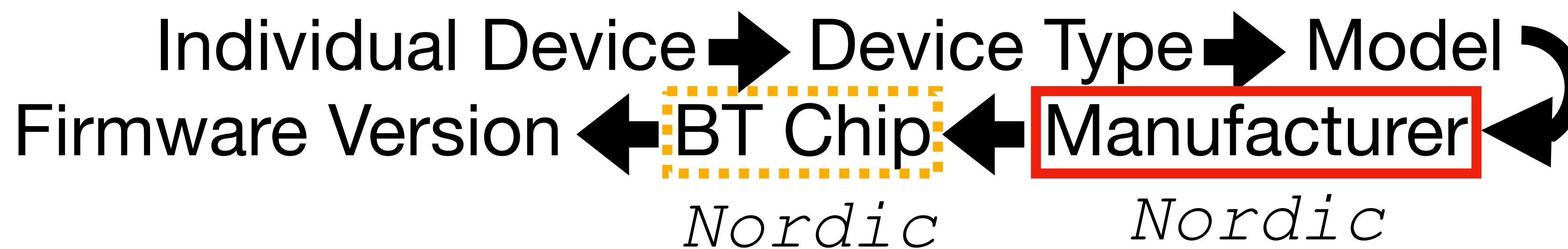

UUID128Print  
DATABASE LOOKUP

UUID128: 6e400001-b5a3-f393-e0a9-e50e24dcca9e

## ASSUMPTION:

UUID128Prints can be reused *within* Manufacturers,  
but not reused *between* Manufacturers



# iBeacon: "The other UUID128!"

## UUID128Print

- One of the most common types of "Manufacturer-Specific Data" (MSD) is the Apple-specified iBeacon (<https://developer.apple.com/ibeacon/>)
- It contains a UUID128 that beacon-deployers are supposed to associate with themselves, a Major ID and Minor ID that they're supposed to associate with individual beacons (e.g. Major ID for a country/store, and minor ID for an individual beacon)

```
Device Company ID: 0x004c (Apple, Inc.) - take with a grain of salt, not all companies populate this accurately!  
  Endianness-flipped device company ID (in case the vendor used the wrong endianness): 0x4c00 (No Match)  
Raw Data: 0215f34ebac47cd74027878e55f4e71d03090000000088  
Apple iBeacon:  
  UUID128: f34ebac4-7cd7-4027-878e-55f4e71d0309  
  Major ID: 0000  
  Minor ID: 0000  
  RSSI at 1 meter: -120dBm  
  In BT LE Data (LE_bdaddr_to_mf_specific), bdaddr_random = 0 (Public)  
  This was found in an event of type 3 which corresponds to Non-Connectable Undirected Advertising (ADV_NONCONN_IND)
```



# iBeacon: "The other UUID128!"

## UUID128Print

- Detective Work : GATT -> Google Search

```
GATT Characteristic: 00002a29-0000-1000-8000-00805f9b34fb (Manufacturer Name String), Properties: 2 ('Readable' )
GATT Characteristic value read as b'MILWAUKEE TOOL'
GATT Descriptor: 00002803-0000-1000-8000-00805f9b34fb, Descriptor Handle: 9
GATT Descriptor: 00002a24-0000-1000-8000-00805f9b34fb, Descriptor Handle: 10
GATT Characteristic: 00002a24-0000-1000-8000-00805f9b34fb (Model Number String), Properties: 2 ('Readable' )
GATT Characteristic value read as b'BLE112'
GATT Descriptor: 00002803-0000-1000-8000-00805f9b34fb, Descriptor Handle: 11
GATT Descriptor: 00002a25-0000-1000-8000-00805f9b34fb, Descriptor Handle: 12
GATT Characteristic: 00002a25-0000-1000-8000-00805f9b34fb (Serial Number String), Properties: 2 ('Readable' )
GATT Characteristic value read as b'123456789'
```



# iBeacon: "The other UUID128!"

## UUID128Print

- Detective Work : GATT -> Google Search

```
istic: 00002a29-0000-1000-8000-00805f9b34fb (Manufacturer  
istic value read as b'MILWAUKEE TOOL'  
803-0000-1000-8000-00805f9b34fb, Descriptor Handle: 9  
a24-0000-1000-8000-00805f9b34fb, Descriptor Handle: 10  
istic: 00002a24-0000-1000-8000-00805f9b34fb (Model Number  
istic value read as b'BLE112'  
803-0000-1000-8000-00805f9b34fb, Descriptor Handle: 11  
a25-0000-1000-8000-00805f9b34fb, Descriptor Handle: 12  
istic: 00002a25-0000-1000-8000-00805f9b34fb (Serial Number  
istic value read as b'123456789'
```



# iBeacon: "The other UUID128!"

## UUID128Print

- Detective Work 🕵️: GATT -> Google Search

```
istic: 00002a29-0000-1000-8000-00805f9b34fb (Manufacturer I
istic value read as b'MILWAUKEE TOOL
803-0000-1000-8000-00805f9b34fb, Descriptor Handle: 9
a24-0000-1000-8000-00805f9b34fb, Descriptor Handle: 10
istic: 00002a24-0000-1000-8000-00805f9b34fb (Model Number
istic value read as b'BLE112'
803-0000-1000-8000-00805f9b34fb, Descriptor Handle: 11
a25-0000-1000-8000-00805f9b34fb, Descriptor Handle: 12
istic: 00002a25-0000-1000-8000-00805f9b34fb (Serial Number
istic value read as b'123456789'
```



# iBeacon: "The other UUID128"

## UUID128Print

- Detective Work 🕵️: GATT -> Google Search



```
istic: 00002a29-0000-1000-8000-00805f9b34fb (Manufacturer  
istic value read as b' MILWAUKEE TOOL  
803-0000-1000-8000-00805f9b34fb, Descriptor Handle: 9  
a24-0000-1000-8000-00805f9b34fb, Descriptor Handle: 10  
istic: 00002a24-0000-1000-8000-00805f9b34fb (Model Number  
istic value read as b'BLE112'  
803-0000-1000-8000-00805f9b34fb, Descriptor Handle: 11  
a25-0000-1000-8000-00805f9b34fb, Descriptor Handle: 12  
istic: 00002a25-0000-1000-8000-00805f9b34fb (Serial Number  
istic value read as b'123456789'
```





# iBeacon: "The other UUID128!"

## UUID128Print

- Detective Work 🕵️: GATT -> Google Search

```
istic: 00002a29-0000-1000-8000-00805f9b34fb (Manufacturer I
istic value read as b' MILWAUKEE TOOL
803-0000-1000-8000-00805f9b34fb, Descriptor Handle: 9
a24-0000-1000-8000-00805f9b34fb, Descriptor Handle: 10
istic: 00002a24-0000-1000-8000-00805f9b34fb (Model Number
istic value read as b'BLE112'
803-0000-1000-8000-00805f9b34fb, Descriptor Handle: 11
a25-0000-1000-8000-00805f9b34fb, Descriptor Handle: 12
istic: 00002a25-0000-1000-8000-00805f9b34fb (Serial Number
istic value read as b'123456789'
```



# iBeacon: "The other UUID128!"

## UUID128Print

- Detective Work 🕵️: GATT -> Google Search

```
istic: 00002a29-0000-1000-8000-00805f9b34fb (Manufacturer I
istic value read as b' MILWAUKEE TOOL
803-0000-1000-8000-00805f9b34fb, Descriptor Handle: 9
a24-0000-1000-8000-00805f9b34fb, Descriptor Handle: 10
istic: 00002a24-0000-1000-8000-00805f9b34fb (Model Number
istic value read as b' BLE112
803-0000-1000-8000-00805f9b34fb, Descriptor Handle: 11
a25-0000-1000-8000-00805f9b34fb, Descriptor Handle: 12
istic: 00002a25-0000-1000-8000-00805f9b34fb (Serial Number
istic value read as b'123456789'
```

Milwaukee tool BLE112 bluetooth



Shopping

Images

Videos

App

News

Maps

Books

Flights

Finance



Milwaukee Tool

<https://www.milwaukeetool.com> > Products

## TICK Tool and Equipment Tracker

**Bluetooth** tracker for **tools** and **equipment** offers multiple attachment options and a low profile design - users can glue, screw, rivet or strap the TICK™...

★★★★★ Rating: 4.7 · 901 reviews

Missing: ~~BLE112~~ | Show results with: [BLE112](#)



Milwaukee Tool

<https://www.milwaukeetool.com> > Products



Milwaukee tool BLE112 bluetooth



Shopping

Images

Videos

App

News

Maps

Books

Flights

Finance

**They make an AirTag "for tools"!  
*Where's your anti-stalking defense now?***



and a low profile design - users can glue, screw, rivet or strap the TICK™

★★★★★ Rating: 4.7 · 901 reviews

Missing: ~~BLE112~~ | Show results with: [BLE112](#)



Milwaukee Tool

<https://www.milwaukeetool.com> > Products



Milwaukee tool BLE112 bluetooth



Shopping

Images

Videos

App

News

Maps

Books

Flights

Finance



Milwaukee Tool

<https://www.milwaukeetool.com> > Products

## TICK Tool and Equipment Tracker

**Bluetooth** tracker for **tools** and **equipment** offers multiple attachment options and a low profile design - users can glue, screw, rivet or strap the TICK™...

★★★★★ Rating: 4.7 · 901 reviews

Missing: ~~BLE112~~ | Show results with: [BLE112](#)



Milwaukee Tool

<https://www.milwaukeetool.com> > Products



Can Milwaukee tools be traced? ▼

---

Does Milwaukee have Bluetooth? ▼

---

Feedback



Silicon Labs

<https://www.silabs.com> > [bluetooth](#) > [device.bled112](#) ⋮

## BLED112

The **BLED112 Bluetooth** Low Energy Dongle integrates all **Bluetooth LE** features. The USB dongle has a virtual COM port that enables seamless ho...



BLE112 bluetooth -"BLED112"



Images

Videos

Manual

Shopping

News

Maps

Books

Flights

Finan

## Sponsored



Mouser Electronics

<https://www.mouser.com>

## BLED112 Bluetooth Smart Dongle - Silicon Labs | Mouser

Mouser is an Authorized Silicon Labs Distributor with Inventory, Prices & Datasheets. Huge Selection of Silicon Labs In Stock with No Minimum Orders & Fast Delivery! Fast Delivery. AS6496 Certified. Authorized Distributor. ISO 9001:2015. Order by 8PM CST.

Get phone number

Selection of Silicon Labs In Stock with No Minimum Orders & Fast Delivery! Fast Delivery.  
AS6496 Certified. Authorized Distributor. ISO 9001:2015. Order by 8PM CST.

📞 Get phone number ▾



Silicon Labs

<https://www.silabs.com> > public > data-sheets ⋮

## BLE112 Datasheet

**BLE112** offers all **Bluetooth** Low Energy features: radio, stack, profiles and application space for customer applications, so no external processor is needed. The ...

26 pages



Digikey

<https://forum.digikey.com> > getting-started-with-the-bl... ⋮

## Getting Started with the BlueGiga BLE112 Bluetooth Low ...

Mar 9, 2021 — Purpose. This page explains how to set up the Silicon Labs **BLE112**

**Bluetooth** Low Energy module to communicate with a microcontroller via UART.

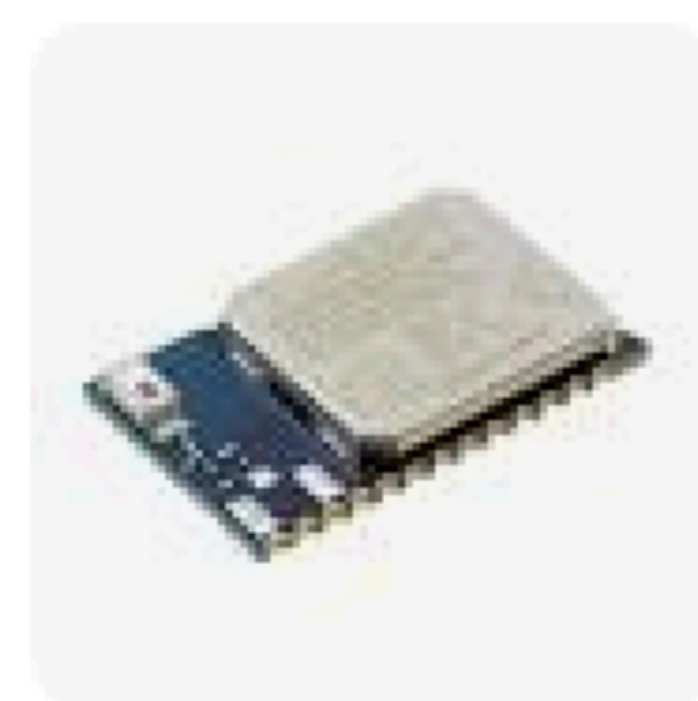





<https://www.silabs.com/documents/public/data-sheets/ble112-data-sheet.pdf>

Not Recommended for New Designs

## **BLE112**

DATA SHEET

Wednesday, 02 December 2020

Version 1.8



Selection of Silicon Labs In Stock with No Minimum Orders & Fast Delivery! Fast Delivery.  
AS6496 Certified. Authorized Distributor. ISO 9001:2015. Order by 8PM CST.

 Get phone number 



Silicon Labs

<https://www.silabs.com> > public > data-sheets 

## BLE112 Datasheet

**BLE112** offers all **Bluetooth** Low Energy features: radio, stack, profiles and application space for customer applications, so no external processor is needed. The ...

36 pages



Digikey

<https://forum.digikey.com> > getting-started-with-the-bl... 

## Getting Started with the BlueGiga BLE112 Bluetooth Low ...

Mar 9, 2021 — Purpose. This page explains how to set up the Silicon Labs **BLE112**

**Bluetooth** Low Energy module to communicate with a microcontroller via UART.

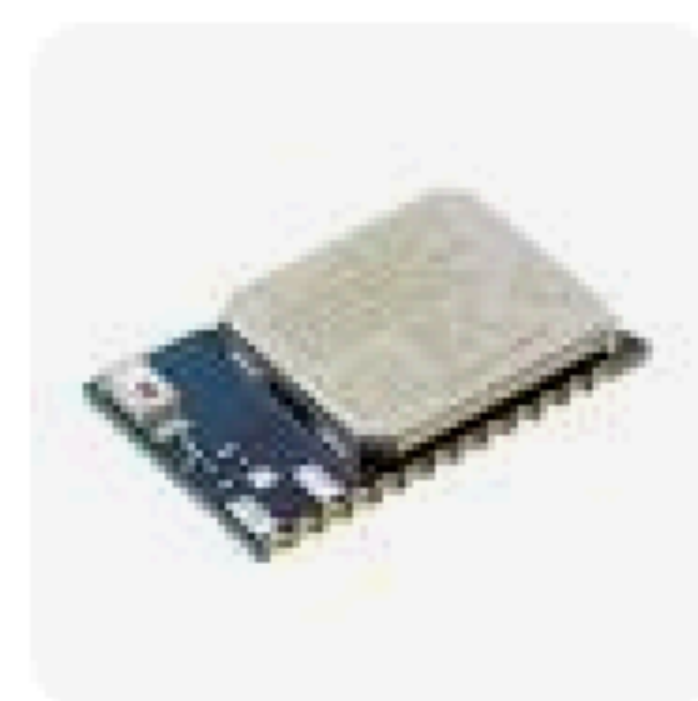

Selection of Silicon Labs In Stock with No Minimum Orders & Fast Delivery! Fast Delivery.  
AS6496 Certified. Authorized Distributor. ISO 9001:2015. Order by 8PM CST.

📞 Get phone number ▾



Silicon Labs

<https://www.silabs.com> > public > data-sheets ⋮

## BLE112 Datasheet

**BLE112** offers all **Bluetooth** Low Energy features: radio, stack, profiles and application space for customer applications, so no external processor is needed. The ...

36 pages



Digikey

<https://forum.digikey.com> > getting-started-with-the-bl... ⋮

## Getting Started with the BlueGiga BLE112 Bluetooth Low ...

Mar 9, 2021 — Purpose. This page explains how to set up the Silicon Labs **BLE112**

**Bluetooth** Low Energy module to communicate with a microcontroller via UART





# iBeacon: "The other UUID128!"

## UUID128Print

- Detective Work : GATT -> Google Search -> **BLE112 == Bluegiga module**

```
n:
Service: Begin Handle: 1 End Handle: 5 UUID128: 00001800-0000-1000-8000-00805f9b34fb (Generic Access)
GATT Descriptor: 00002800-0000-1000-8000-00805f9b34fb, Descriptor Handle: 1
GATT Descriptor: 00002803-0000-1000-8000-00805f9b34fb, Descriptor Handle: 2
GATT Descriptor: 00002a00-0000-1000-8000-00805f9b34fb, Descriptor Handle: 3
    GATT Characteristic: 00002a00-0000-1000-8000-00805f9b34fb (Device Name), Properties: 10 ('Readable' 'Writable' )
    GATT Characteristic value read as b'000C007771MKE '
GATT Descriptor: 00002803-0000-1000-8000-00805f9b34fb, Descriptor Handle: 4
GATT Descriptor: 00002a01-0000-1000-8000-00805f9b34fb, Descriptor Handle: 5
    GATT Characteristic: 00002a01-0000-1000-8000-00805f9b34fb (Appearance), Properties: 2 ('Readable' )
    GATT Characteristic value read as b'\x00\x01'
        Appearance decodes as: Category (8): Tag, Sub-Category (0): Generic
Service: Begin Handle: 6 End Handle: 12 UUID128: 0000180a-0000-1000-8000-00805f9b34fb (Device Information)
GATT Descriptor: 00002800-0000-1000-8000-00805f9b34fb, Descriptor Handle: 6
GATT Descriptor: 00002803-0000-1000-8000-00805f9b34fb, Descriptor Handle: 7
GATT Descriptor: 00002a29-0000-1000-8000-00805f9b34fb, Descriptor Handle: 8
    GATT Characteristic: 00002a29-0000-1000-8000-00805f9b34fb (Manufacturer Name String), Properties: 2 ('Readable' )
    GATT Characteristic value read as b'MILWAUKEE TOOL'
GATT Descriptor: 00002803-0000-1000-8000-00805f9b34fb, Descriptor Handle: 9
GATT Descriptor: 00002a24-0000-1000-8000-00805f9b34fb, Descriptor Handle: 10
    GATT Characteristic: 00002a24-0000-1000-8000-00805f9b34fb (Model Number String), Properties: 2 ('Readable' )
    GATT Characteristic value read as b'BLE112'
GATT Descriptor: 00002803-0000-1000-8000-00805f9b34fb, Descriptor Handle: 11
GATT Descriptor: 00002a25-0000-1000-8000-00805f9b34fb, Descriptor Handle: 12
    GATT Characteristic: 00002a25-0000-1000-8000-00805f9b34fb (Serial Number String), Properties: 2 ('Readable' )
    GATT Characteristic value read as b'123456789'
```

0:c4:7a:

IEEE OUI (00:07:80): Bluegiga Technologies 0Y

Inquiry Result Device info.

d.

er found.

ata found.

pecific Data:

Company ID: 0x6501 (No Match) - take with a grain of salt, not all companies pop

Endianness-flipped device company ID (in case the vendor used the wrong endiar

a: 000c00777100

In BT LE Data (LE\_bdaddr\_to\_mf\_specific), bdaddr\_random = 0 (Public)

This was found in an event of type 0 which corresponds to Connectable Undirecte

ice Data found.

n:

ervice: Begin Handle: 1 End Handle: 5

UUID128: 00001800-0000-1000-8000

IEEE OUI (00:07:80): Bluegiga Technologies 0Y

Inquiry Result Device info.

d.

er found.

ata found.

pecific Data:

Company ID: 0x6501 (No Match) - take with a grain of salt, not all companies pop

Endianness-flipped device company ID (in case the vendor used the wrong endiar

a: 000c00777100

In BT LE Data (LE\_bdaddr\_to\_mf\_specific), bdaddr\_random = 0 (Public)

This was found in an event of type 0 which corresponds to Connectable Undirecte

ice Data found.

n:

ervice: Begin Handle: 1 End Handle: 5

UUID128: 00001800-0000-1000-8000

bluegiga silicon labs



Images

Bluetooth

App

Videos

BLED112

BLE GUI tool

UART demo

Shopp



Silicon Labs

<https://www.silabs.com> > [developers](#) > [bluegiga-blueto...](#)

## Bluegiga Bluetooth Smart Software Development Kit (SDK)

**Bluegiga Bluetooth Smart Software** is a complete Bluetooth Smart software stack for **Bluegiga** Legacy Bluetooth Smart products, such as BLE112, BLE113, ...

People also ask

Is Silicon Labs safe?





## Bluegiga Legacy Modules (BLE)

The **Bluegiga** Legacy Bluetooth 4.0 Low Energy (BLE) Modules were launched in 2011. For new Bluetooth 5 designs, we recommend our latest Bluetooth modules.



Silicon Labs Newsroom

<https://news.silabs.com> > 2015-02-03-Silicon-Labs-Ac... ⋮

## Silicon Labs Acquires Bluegiga, a Leader in Bluetooth and ...

Feb 3, 2015 — **Silicon Labs** completed the acquisition of **Bluegiga** Technologies Oy on January 30, 2015. Under the agreement, **Bluegiga** investors received ...

## Bluegiga Legacy Modules (BLE)

The **Bluegiga** Legacy Bluetooth 4.0 Low Energy (BLE) Modules were launched in 2011. For new Bluetooth 5 designs, we recommend our latest Bluetooth modules.



Silicon Labs Newsroom

<https://news.silabs.com/2015-02-03-Silicon-Labs-Ac>

### Silicon Labs Acquires Bluegiga, a Leader in Bluetooth and ...

Feb 3, 2015 — **Silicon Labs** completed the acquisition of **Bluegiga** Technologies Oy on January 30, 2015. Under the agreement, **Bluegiga** investors received ...



# iBeacon: "The other UUID128!"

## UUID128Print

- Detective Work : GATT -> Google Search -> BLE112 == Bluegiga module -> Google Search -> **Bluegiga == Silicon Labs**



# iBeacon: "The other UUID128!"

## UUID128Print

- Detective Work 🕵️: GATT -> Google Search -> BLE112 == Bluegiga module -> Google Search -> Bluegiga == Silicon Labs

```
istic: 00002a29-0000-1000-8000-00805f9b34fb (Manufacturer  
istic value read as b'MILWAUKEE TOOL'  
803-0000-1000-8000-00805f9b34fb, Descriptor Handle: 9  
a24-0000-1000-8000-00805f9b34fb, Descriptor Handle: 10  
istic: 00002a24-0000-1000-8000-00805f9b34fb (Model Number  
istic value read as b'BLE112'  
803-0000-1000-8000-00805f9b34fb, Descriptor Handle: 11  
a25-0000-1000-8000-00805f9b34fb, Descriptor Handle: 12  
istic: 00002a25-0000-1000-8000-00805f9b34fb Serial Number  
istic value read as b'123456789'
```

# iBeacon: "The other UUID128!"

## UUID128Print

- Detective Work 🕵️: GATT -> Google Search -> BLE112 == Bluegiga module -> Google Search -> Bluegiga == Silicon Labs

```
istic: 00002a29-0000-1000-8000-00805f9b34fb (Manufacturer  
istic value read as b'MILWAUKEE TOOL'  
803-0000-1000-8000-00805f9b34fb, Descriptor Handle: 9  
a24-0000-1000-8000-00805f9b34fb, Descriptor Handle: 10  
istic: 00002a24-0000-1000-8000-00805f9b34fb (Model Number  
istic value read as b'BLE112'  
8000-1000-8000-00805f9b34fb, Descriptor Handle: 11  
805f9b34fb, Descriptor Handle: 12  
1000-8000-00805f9b34fb  
Serial Number  
123456789
```



Kinda seems uninitialized

BLE112

123456789

Serial Number

```
n:
Service: Begin Handle: 1 End Handle: 5 UUID128: 00001800-0000-1000-8000-00805f9b34fb (Generic Access)
GATT Descriptor: 00002800-0000-1000-8000-00805f9b34fb, Descriptor Handle: 1
GATT Descriptor: 00002803-0000-1000-8000-00805f9b34fb, Descriptor Handle: 2
GATT Descriptor: 00002a00-0000-1000-8000-00805f9b34fb, Descriptor Handle: 3
    GATT Characteristic: 00002a00-0000-1000-8000-00805f9b34fb (Device Name), Properties: 10 ('Readable' 'Writable' )
    GATT Characteristic value read as b'000C007771MKE '
GATT Descriptor: 00002803-0000-1000-8000-00805f9b34fb, Descriptor Handle: 4
GATT Descriptor: 00002a01-0000-1000-8000-00805f9b34fb, Descriptor Handle: 5
    GATT Characteristic: 00002a01-0000-1000-8000-00805f9b34fb (Appearance), Properties: 2 ('Readable' )
    GATT Characteristic value read as b'\x00\x01'
        Appearance decodes as: Category (8): Tag, Sub-Category (0): Generic
Service: Begin Handle: 6 End Handle: 12 UUID128: 0000180a-0000-1000-8000-00805f9b34fb (Device Information)
GATT Descriptor: 00002800-0000-1000-8000-00805f9b34fb, Descriptor Handle: 6
GATT Descriptor: 00002803-0000-1000-8000-00805f9b34fb, Descriptor Handle: 7
GATT Descriptor: 00002a29-0000-1000-8000-00805f9b34fb, Descriptor Handle: 8
    GATT Characteristic: 00002a29-0000-1000-8000-00805f9b34fb (Manufacturer Name String), Properties: 2 ('Readable' )
    GATT Characteristic value read as b'MILWAUKEE TOOL'
GATT Descriptor: 00002803-0000-1000-8000-00805f9b34fb, Descriptor Handle: 9
GATT Descriptor: 00002a24-0000-1000-8000-00805f9b34fb, Descriptor Handle: 10
    GATT Characteristic: 00002a24-0000-1000-8000-00805f9b34fb (Model Number String), Properties: 2 ('Readable' )
    GATT Characteristic value read as b'BLE112'
GATT Descriptor: 00002803-0000-1000-8000-00805f9b34fb, Descriptor Handle: 11
GATT Descriptor: 00002a25-0000-1000-8000-00805f9b34fb, Descriptor Handle: 12
    GATT Characteristic: 00002a25-0000-1000-8000-00805f9b34fb (Serial Number String), Properties: 2 ('Readable' )
    GATT Characteristic value read as b'123456789'
```



# iBeacon: "The other UUID128!"

## UUID128Print

Manufacturer-specific Data:

```
Device Company ID: 0x6501 (No Match) - take with a grain of salt, not all companies populate  
Endianness-flipped device company ID (in case the vendor used the wrong endianness): 0x0165 (Milwaukee Electric  
Raw Data: 000c00777100  
In BT LE Data (LE_bdaddr_to_mf_specific), bdaddr_random = 0 (Public)  
This was found in an event of type 0 which corresponds to Connectable Undirected Advertising (ADV_IND)
```

Bytes of Device Data found.

Information:

```
GATT Service: Begin Handle: 1 End Handle: 5 UUID128: 00001800-0000-1000-8000-00805f9b34fb (Generic Access)  
GATT Descriptor: 00002800-0000-1000-8000-00805f9b34fb, Descriptor Handle: 1  
GATT Descriptor: 00002803-0000-1000-8000-00805f9b34fb, Descriptor Handle: 2  
GATT Descriptor: 00002a00-0000-1000-8000-00805f9b34fb, Descriptor Handle: 3  
GATT Characteristic: 00002a00-0000-1000-8000-00805f9b34fb (Device Name), Properties: 10 ('Readable' 'Writable')  
GATT Characteristic value read as b'000C007771MKE '  
GATT Descriptor: 00002803-0000-1000-8000-00805f9b34fb, Descriptor Handle: 4  
GATT Descriptor: 00002a01-0000-1000-8000-00805f9b34fb, Descriptor Handle: 5  
GATT Characteristic: 00002a01-0000-1000-8000-00805f9b34fb (Appearance), Properties: 2 ('Readable' )  
GATT Characteristic value read as b'\x00\x01'  
Appearance decodes as: Category (8): Tag, Sub-Category (0): Generic  
GATT Service: Begin Handle: 6 End Handle: 12 UUID128: 0000180a-0000-1000-8000-00805f9b34fb (Device Information)  
GATT Descriptor: 00002800-0000-1000-8000-00805f9b34fb, Descriptor Handle: 6  
GATT Descriptor: 00002803-0000-1000-8000-00805f9b34fb, Descriptor Handle: 7  
GATT Descriptor: 00002a29-0000-1000-8000-00805f9b34fb, Descriptor Handle: 8  
GATT Characteristic: 00002a29-0000-1000-8000-00805f9b34fb (Manufacturer Name String), Properties: 2 ('Readable' )  
GATT Characteristic value read as b'MILWAUKEE TOOL '  
GATT Descriptor: 00002803-0000-1000-8000-00805f9b34fb, Descriptor Handle: 9
```



# iBeacon: "The other UUID128!"

## UUID128Print

```

Manufacturer-specific Data:
Device Company ID: 0x6501 (No Match) - take with a grain of salt, not all companies populate
Endianness-flipped device company ID (in case the vendor used the wrong endianness): 0x0165 (Milwaukee Electric
Raw Data: 000c00777100
In BT LE Data (LE_bdaddr_to_mf_specific), b...andom = 0 (Public)
This was found in an event of type 0 which...s to Connectable Undirected Advertising (ADV_IND)

s of Device Data found.

formation:
GATT Service: Begin Handle: 1 End Handle: 5 UUID128:
GATT Descriptor: 00002800-0000-1000-8000-00805f9b34fb, Desc
GATT Descriptor: 00002803-0000-1000-8000-00805f9b34fb, Desc
GATT Descriptor: 00002a00-0000-1000-8000-00805f9b34fb, Desc
GATT Characteristic: 00002a00-0000-1000-8000-00805f9b34fb (Appearance), Properties: 2 ('Readable')
GATT Characteristic value read as b'000c007771MKE '
GATT Descriptor: 00002803-0000-1000-8000-00805f9b34fb, Descriptor Handle: 4
GATT Descriptor: 00002a01-0000-1000-8000-00805f9b34fb, Descriptor Handle: 5
GATT Characteristic: 00002a01-0000-1000-8000-00805f9b34fb (Appearance), Properties: 2 ('Readable')
GATT Characteristic value read as b'\x00\x01'
Appearance decodes as: Category (8): Tag, Sub-Category (0): Generic
GATT Service: Begin Handle: 6 End Handle: 12 UUID128: 0000180a-0000-1000-8000-00805f9b34fb (Device Information)
GATT Descriptor: 00002800-0000-1000-8000-00805f9b34fb, Descriptor Handle: 6
GATT Descriptor: 00002803-0000-1000-8000-00805f9b34fb, Descriptor Handle: 7
GATT Descriptor: 00002a29-0000-1000-8000-00805f9b34fb, Descriptor Handle: 8
GATT Characteristic: 00002a29-0000-1000-8000-00805f9b34fb (Manufacturer Name String), Properties: 2 ('Read
GATT Characteristic value read as b'MILWAUKEE TOOL'
GATT Descriptor: 00002803-0000-1000-8000-00805f9b34fb, Descriptor Handle: 9

```



They seem to be using a big-endian BT CID, rather than the more common little-endian





# iBeacon: "The other UUID128!"

## UUID128Print

Manufacturer-specific Data:

Device Company ID: 0x6501 (No Match) - take with a grain of salt, not all companies populate this accurately!  
Endianness-flipped device company ID (in case the vendor used the wrong endianness): 0x0165 (Milwaukee Electric Tool)

Raw Data: 000c03249000

In BT LE Data (LE\_bdaddr\_to\_mf\_specific), bdaddr\_random = 0 (Public)

This was found in an event of type 0 which corresponds to Connectable Undirected Advertising (ADV\_IND)

Device Company ID: 0x004c (Apple, Inc.) - take with a grain of salt, not all companies populate this accurately!

Endianness-flipped device company ID (in case the vendor used the wrong endianness): 0x4c00 (No Match)

Raw Data: 0215f34ebac47cd74027878e55f4e71d03090000000088

Apple iBeacon:

UUID128: f34ebac4-7cd7-4027-878e-55f4e71d0309

Major ID: 0000

Minor ID: 0000

RSSI at 1 meter: -120dBm

In BT LE Data (LE\_bdaddr\_to\_mf\_specific), bdaddr\_random = 0 (Public)

This was found in an event of type 3 which corresponds to Non-Connectable Undirected Advertising (ADV\_NONCONN\_IND)



# iBeacon: "The other UUID128!"

## UUID128Print

```
Manufacturer-specific Data:  
Device Company ID: 0x6501 (No Match) - take with a grain of salt, not all companies populate this accurately!  
  Endianness-flipped device company ID (in case the vendor used the wrong endianness): 0x0165 (Milwaukee Electric  
Raw Data: 000c03249000  
  In BT LE Data (LE_bdaddr_to_mf_specific), bdaddr_random = 0 (Public)  
  This was found in an event of type 0 which corresponds to Connectable Undirected Advertising (ADV_IND)  
Device Company ID: 0x004c (Apple, Inc.) - take with a grain of salt, not all companies populate this accurately!  
  Endianness-flipped device company ID (in case the vendor used the wrong endianness): 0x4c00 (No Match)  
Raw Data: 0215f34ebac47cd74027878e55f4e71d030900000000088  
Apple iBeacon:  
  UUID128: 0215f34e-bac4-7cd7-4027-878e-55f4e71d0309  
    Major ID: 0000  
    Minor ID: 0000  
  RSSI at 1 meter: -120dBm  
  In BT LE Data (LE_bdaddr_to_mf_specific), bdaddr_random = 0 (Public)  
  This was found in an event of type 3 which corresponds to Non-Connectable Undirected Advertising (ADV_NONCONN_IND)
```



# iBeacon: "The other UUID128!"

## UUID128Print

```

Manufacturer-specific Data:
Device Company ID: 0x6501 (No Match) - take with a grain of salt, not all companies populate this accurately!
  Endianness-flipped device company ID (in case the vendor used the wrong endianness): 0x0165 (Milwaukee Electric Tool)
Raw Data: 000c03249000
  In BT LE Data (LE_bdaddr_to_mf_specific), bdaddr_random = 0 (Public)
  This was found in an event of type 0 which corresponds to Connectable Undirected Advertising (ADV_IND)
Device Company ID: 0x004c (Apple, Inc.) - take with a grain of salt, not all companies populate this accurately!
  Endianness-flipped device company ID (in case the vendor used the wrong endianness): 0x4c00 (No Match)
Raw Data: 0215f34ebac47cd74027878e55f4e71d030900000000088
Apple iBeacon:
  UUID128: f31547cd7-4027-878e-55f4e71d0309
    Major ID: 0000
    Minor ID: 0000
  RSSI at 1 meter: -120dBm
  In BT LE Data (LE_bdaddr_to_mf_specific), bdaddr_random = 0 (Public)
  This was found in an event of type 1 which corresponds to Non-Connectable Undirected Advertising (ADV_NONCONN_IND)

```

Major ID: 0000  
 Minor ID: 0000

Kinda seems uninitialized





# iBeacon: "The other UUID128!"

## UUID128Print

- Detective Work : GATT -> Google Search -> BLE112 == Bluegiga module -> Google Search -> Bluegiga == Silicon Labs -> iBeacons

### turer-specific Data:

Device Company ID: 0x6501 (No Match) - take with a grain of salt, not all companies populate this accurately!

Endianness-flipped device company ID (in case the vendor used the wrong endianness): 0x0165 (Milwaukee Electric T

Raw Data: 000c03249000

In BT LE Data (LE\_bdaddr\_to\_mf\_specific), bdaddr\_random = 0 (Public)

This was found in an event of type 0 which corresponds to Connectable Undirected Advertising (ADV\_IND)

Device Company ID: 0x004c (Apple, Inc.) - take with a grain of salt, not all companies populate this accurately!

Endianness-flipped device company ID (in case the vendor used the wrong endianness): 0x4c00 (No Match)

Raw Data: 0215f34ebac47cd74027878e55f4e71d03090000000088

### Apple iBeacon:

UUID128: f34ebac4-7cd7-4027-878e-55f4e71d0309

Major ID: 0000

Minor ID: 0000

RSSI at 1 meter: -120dBm

In BT LE Data (LE\_bdaddr\_to\_mf\_specific), bdaddr\_random = 0 (Public)

This was found in an event of type 3 which corresponds to Non-Connectable Undirected Advertising (ADV\_NONCONN\_IND)



# iBeacon: "The other UUID128!"

## UUID128Print

- Detective Work 🕵️: GATT -> Google Search -> BLE112 == Bluegiga module -> Google Search -> Bluegiga == Silicon Labs -> iBeacons

```
turer-specific Data:  
Device Company ID: 0x6501 (No Match) - take with a grain of salt, not all companies populate this accurately!  
    Endianness-flipped device company ID (in case the vendor used the wrong endianness): 0x0165 (Milwaukee Electric T  
Raw Data: 000c03249000  
    In BT LE Data (LE_bdaddr_to_mf_specific), bdaddr_random = 0 (Public)  
    This was found in an event of type 0 which corresponds to Connectable Undirected Advertising (ADV_IND)  
Device Company ID: 0x004c (Apple, Inc.) - take with a grain of salt, not all companies populate this accurately!  
    Endianness-flipped device company ID (in case the vendor used the wrong endianness): 0x4c00 (No Match)  
Raw Data: 0215f34ebac47cd74027878e55f4e71d03090000000088  
Apple iBeacon:  
    UUID128: 624...4-7cd7-4027-878e-55f4e71d0309  
    Major ID: 0000  
    Minor ID: 0000  
    RSSI at 1 meter: -120dBm  
    In BT LE Data (LE_bdaddr_to_mf_specific), bdaddr_random = 0 (Public)  
    This was found in an event of type 3 which corresponds to Non-Connectable Undirected Advertising (ADV_NONCONN_IND)
```



# iBeacon: "The other UUID128!"

## UUID128Print

- Detective Work 🕵️: GATT -> Google Search -> BLE112 == Bluegiga module -> Google Search -> Bluegiga == Silicon Labs -> iBeacons

```

turer-specific Data:
Device Company ID: 0x6501 (No Match) - take with a grain of salt, not all companies populate this accurately!
  Endianness-flipped device company ID (in case the vendor used the wrong endianness): 0x0165 (Milwaukee Electric T
Raw Data: 000c03249000
  In BT LE Data (LE_bdaddr_to_mf_specific), bdaddr_random = 0 (Public)
  This was found in an event of type 0 which corresponds to Connectable Undirected Advertising (ADV_IND)
Device Company ID: 0x004c (Apple, Inc.) - take with a grain of salt, not all companies populate this accurately!
  Endianness-flipped device company ID (in case the vendor used the wrong endianness): 0x4c00 (No Match)
Raw Data: 0215f34ebac47cd74027878e55f4e71d030900000000088
Apple iBeacon:
  UUID128: f21...4-7cd7-4027-878e-55f4e71d0309
  Major ID: 0000
  Minor ID: 0000
  RSSI at 1 meter: -120dBm
  In BT LE Data (LE_bdaddr_to_mf_specific), bdaddr_random = 0 (Public)
  This was found in an event of type 1 which corresponds to Non-Connectable Undirected Advertising (ADV_NONCONN_IND)

```

Major ID: 0000  
Minor ID: 0000

Kinda seems uninitialized





# iBeacon: "The other UUID128!"

## UUID128Print

- Detective Work 🕵️: GATT -> Google Search -> BLE112 == Bluegiga module -> Google Search -> Bluegiga == Silicon Labs -> iBeacons -> UUID128

```
turer-specific Data:  
Device Company ID: 0x6501 (No Match) - take with a grain of salt, not all companies populate this accurately!  
    Endianness-flipped device company ID (in case the vendor used the wrong endianness): 0x0165 (Milwaukee Electric T  
Raw Data: 000c03249000  
    In BT LE Data (LE_bdaddr_to_mf_specific), bdaddr_random = 0 (Public)  
    This was found in an event of type 0 which corresponds to Connectable Undirected Advertising (ADV_IND)  
Device Company ID: 0x004c (Apple, Inc.) - take with a grain of salt, not all companies populate this accurately!  
    Endianness-flipped device company ID (in case the vendor used the wrong endianness): 0x4c00 (No Match)  
Raw Data: 0215f34ebac47cd74027878e55f4e71d030900000000088  
Apple iBeacon:  
    UUID128: f34ebac4-7cd7-4027-878e-55f4e71d0309  
    Major ID: 0000  
    Minor ID: 0000  
    RSSI at 1 meter: -120dBm  
    In BT LE Data (LE_bdaddr_to_mf_specific), bdaddr_random = 0 (Public)  
    This was found in an event of type 3 which corresponds to Non-Connectable Undirected Advertising (ADV_NONCONN_IND)
```





# iBeacon: "The other UUID128!"

## UUID128Print

- Detective Work 🕵️: GATT -> Google Search -> BLE112 == Bluegiga module -> Google Search -> Bluegiga == Silicon Labs -> iBeacons -> UUID128

```
turer-specific Data:  
Device Company ID: 0x6501 (No Match) - take with a grain of salt, not all companies populate this accurately!  
  Endianness-flipped device company ID (in case the vendor used the wrong endianness): 0x0165 (Milwaukee Electric T  
Raw Data: 000c03249000  
  In BT LE Data (LE_bdaddr_to_mf_specific), bdaddr_random = 0 (Public)  
  This was found in an event of type 0 which corresponds to Connectable Undirected Advertising (ADV_IND)  
Device Company ID: 0x004c (Apple, Inc.) - take with a grain of salt, not all companies populate this accurately!  
  Endianness-flipped device company ID (in case the vendor used the wrong endianness): 0x4c00 (No Match)  
Raw Data: 0215f34ebac47cd74027878e55f4e71d030900000000088  
Apple iBeacon  
  UUID128: f34ebac4-7cd7-4027-878e-55f4e71d0309  
  Minor ID: 0000  
  RSSI at 1 meter: -120dBm  
  In BT LE Data (LE_bdaddr_to_mf_specific), bdaddr_random = 0 (Public)  
  This was found in an event of type 1 which corresponds to Non-Connectable Undirected Advertising (ADV_NONCONN_IND)
```

UUID128: f34ebac4-7cd7-4027-878e-55f4e71d0309

Where else does  
this UUID128  
appear?

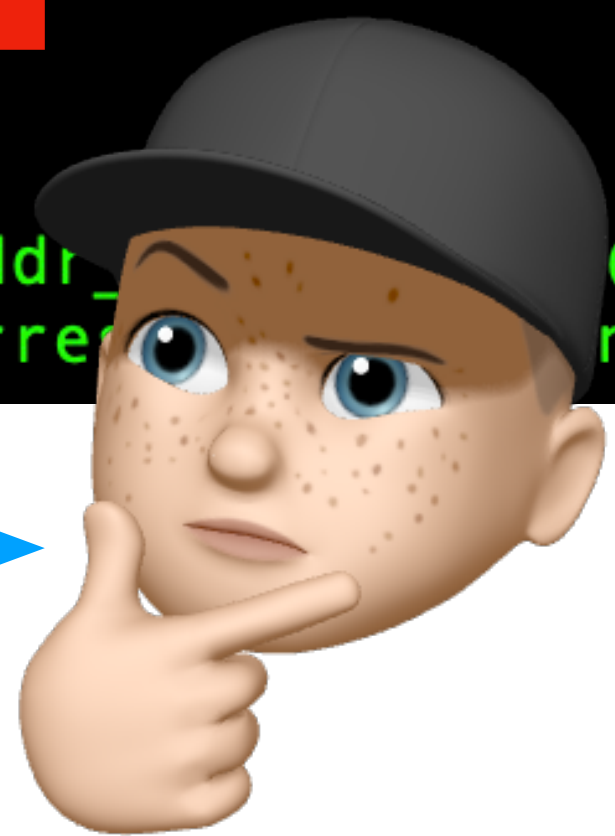





# iBeacon: "The other UUID128!"

## UUID128Print

- Detective Work 🕵️: GATT -> Google Search -> BLE112 == Bluegiga module -> Google Search -> Bluegiga == Silicon Labs -> iBeacons -> UUID128

```
turer-specific Data:  
Device Company ID: 0x6501 (No Match) - take with a grain of salt, not all companies populate this accurately!  
    Endianness-flipped device company ID (in case the vendor used the wrong endianness): 0x0165 (Milwaukee Electric T  
Raw Data: 000c03249000  
    In BT LE Data (LE_bdaddr_to_mf_specific), bdaddr_random = 0 (Public)  
    This was found in an event of type 0 which corresponds to Connectable Undirected Advertising (ADV_IND)  
Device Company ID: 0x004c (Apple, Inc.) - take with a grain of salt, not all companies populate this accurately!  
    Endianness-flipped device company ID (in case the vendor used the wrong endianness): 0x4c00 (No Match)  
Raw Data: 0215f34ebac47cd74027878e55f4e71d030900000000088  
Apple iBeacon  
    UUID128: f34ebac4-7cd7-4027-878e-55f4e71d0309  
Minor ID: 0000  
RSSI at 1 meter: -120dBm  
In BT LE Data (LE_bdaddr_to_mf_specific), bdaddr_random = 0 (Public)  
This was found in an event of type 3 which corresponds to Non-Connectable Undirected Advertising (ADV_NONCONN_IND)
```





# iBeacon: "The other UUID128!"

## UUID128Print

- Detective Work 🕵️: GATT -> Google Search -> BLE112 == Bluegiga module -> Google Search -> Bluegiga == Silicon Labs -> iBeacons -> UUID128

```

turer-specific Data:
Device Company ID: 0x6501 (No Match) - take with a grain of salt, not all companies populate this accurately!
  Endianness-flipped device company ID (in case the vendor used the wrong endianness): 0x0165 (Milwaukee Electric T
Raw Data: 000c03249000
  In BT LE Data (LE_bdaddr_to_mf_specific), bdaddr_random = 0 (Public)
  This was found in an event of type 0 which corresponds to Connectable Undirected Advertising (ADV_IND)
Device Company ID: 0x004c (Apple, Inc.) - take with a grain of salt, not all companies populate this accurately!
  Endianness-flipped device company ID (in case the vendor used the wrong endianness): 0x4c00 (No Match)
Raw Data: 0215f34ebac47cd74027878e55f4e71d030900000000088
Apple iBeacon:
  UUID128: f34ebac4-7cd7-4027-878e-55f4e71d0309
  Minor ID: 0000
  RSSI:
  In B:
  This:
  bdaddr_random = 0 (Public)
  corre:
  n-Connectable Undirected Advertising (ADV_NONCONN_IND)

```

UUID128: f34ebac4-7cd7-4027-878e-55f4e71d0309

Let's search for this UUID128, but remove anything associated with Milwaukee...



=====

For bdaddr = 84:71:27:69:c3:dc:

Company Name by IEEE OUI (84:71:27): Silicon Laboratories

No BTC Extended Inquiry Result Device info.

No Names found.

No UUID16s found.

No transmit power found.

No Appearance data found.

Manufacturer-specific Data:

Device Company ID: 0x004c (Apple, Inc.) - take with a grain of salt, not all companies populate this accurately!

Endianness-flipped device company ID (in case the vendor used the wrong endianness): 0x4c00 (No Match)

Raw Data: 0215f34ebac47cd74027878e55f4e71d03090000000088

Apple iBeacon:

UUID128: f34ebac4-7cd7-4027-878e-55f4e71d0309

Major ID: 0000

Minor ID: 0000

RSSI at 1 meter: -120dBm

In BT LE Data (LE\_bdaddr\_to\_mf\_specific), bdaddr\_random = 0 (Public)

This was found in an event of type 3 which corresponds to Non-Connectable Undirected Advertising (ADV\_NONCONN\_IND)

No Class of Device Data found.

No GATT Information found.

No BLE 2thprint Info found.

No BTC 2thprint Info found.

=====

For bdaddr = 84:fd:27:34:d2:62:

Company Name by IEEE OUI (84:fd:27): Silicon Laboratories

No BTC Extended Inquiry Result Device info.

No Names found.

=====

For bdaddr = 84:71:27:69:c3:dc:

Company Name by IEEE OUI (84:71:27) Silicon Laboratories

No BTC Extended Inquiry Result Device info.

No Names found.

No UUID16s found.

No transmit power found.

No Appearance data found.

Manufacturer-specific Data:

Device Company ID: 0x004c (Apple, Inc.) - take with a grain of salt, not all companies populate this accurately!

Endianness-flipped device company ID (in case the vendor used the wrong endianness): 0x4c00 (No Match)

Raw Data: 0215f34ebac47cd74027878e55f4e71d03090000000088

Apple iBeacon:

UUID128: f34ebac4-7cd7-4027-878e-55f4e71d0309

Major ID: 0000

Minor ID: 0000

RSSI at 1 meter: -120dBm

In BT LE Data (LE\_bdaddr\_to\_mf\_specific), bdaddr\_random = 0 (Public)

This was found in an event of type 3 which corresponds to Non-Connectable Undirected Advertising (ADV\_NONCONN\_IND)

No Class of Device Data found.

No GATT Information found.

No BLE 2thprint Info found.

No BTC 2thprint Info found.

=====

For bdaddr = 84:fd:27:34:d2:62:

Company Name by IEEE OUI (84:fd:27): Silicon Laboratories

No BTC Extended Inquiry Result Device info.

No Names found.

This was found in an event of type 3 which corresponds to Non-Connectable Undirected Advertising (ADV\_NONCONN\_IND)

No Class of Device Data found.

No GATT Information found.

No BLE 2thprint Info found.

=====  
For bdaddr = 88:6b:0f:0e:22:f0:

Company Name by IEEE OUI (88:6b:0f) **Bluegiga Technologies 0Y**

No BTC Extended Inquiry Result Device info.

No Names found.

No UUID16s found.

No transmit power found.

No Appearance data found.

Manufacturer-specific Data:

Device Company ID: 0x004c (Apple, Inc.) - take with a grain of salt, not all companies populate this accurately!

Endianness-flipped device company ID (in case the vendor used the wrong endianness): 0x4c00 (No Match)

Raw Data: 0215f34ebac47cd74027878e55f4e71d03090000000088

Apple iBeacon:

UUID128: f34ebac4-7cd7-4027-878e-55f4e71d0309

Major ID: 0000

Minor ID: 0000

RSSI at 1 meter: -120dBm

In BT LE Data (LE\_bdaddr\_to\_mf\_specific), bdaddr\_random = 0 (Public)

This was found in an event of type 3 which corresponds to Non-Connectable Undirected Advertising (ADV\_NONCONN\_IND)

No Class of Device Data found.

No GATT Information found.

No BLE 2thprint Info found.

No BTC 2thprint Info found.

This was found in an event of type 3 which corresponds to Non-Connectable Undirected Advertising (ADV\_NONCONN\_IND)

No Class of Device Data found.

No GATT Information found.

No BLE 2thprint Info found.

=====  
For bdaddr = 88:6b:0f:0e:22:f0:

Company Name by IEEE OUI (88:6b:0f) **Bluegiga Technologies 0Y**

No BTC Extended Inquiry Result Device info.

No Names found.

No UUID16s found.

No transmit power found.

No Appearance data found.

Manufacturer-specific Data:

Device Company ID: 0x004c (Apple, Inc.) - take with a grain of salt  
Endianness-flipped device company ID (in case the vendor is wrong)  
Raw Data: 0215f34ebac47cd74027878e55f4e71d030900000000088

Apple iBeacon:

UUID128: f34ebac4-7cd7-4027-878e-55f4e71d0309

Major ID: 0000

Minor ID: 0000

RSSI at 1 meter: -120dBm

In BT LE Data (LE\_bdaddr\_to\_mf\_specific), bdaddr\_random

This was found in an event of type 3 which corresponds

No Class of Device Data found.

No GATT Information found.

No BLE 2thprint Info found.

No BTC 2thprint Info found.

Does this UUID128, ever appear with any device NOT associated with Silicon Labs or Bluegiga based on the OUI?

accurately!  
(No Match)

ing (ADV\_NONCONN\_IND)



This was found in an event of type 3 which corresponds to Non-Connectable Undirected Advertising (ADV\_NONCONN\_IND)

No Class of Device Data found.

No GATT Information found.

No BLE 2thprint Info found.

=====

For bdaddr = 88:6b:0f:0e:22:f0:

Company Name by IEEE OUI (88:6b:0f): Bluegiga Technologies 0Y

No BTC Extended Inquiry Result Device info.

No Names found.

No UUID16s found.

No transmit power found.

No Appearance data found.

Manufacturer-specific Data:

Device Company ID: 0x004c (Apple, Inc.) - take with a grain of salt, not all companies populate this accurately!

Endianness-flipped device company ID (in case the vendor used the wrong endianness): 0x4c00 (No Match)

Raw Data: 0215f34ebac47cd74027878e55f4e71d03090000000088

Apple iBeacon:

UUID128: f34ebac4-7cd7-4027-878e-55f4e71d0309

Major ID: 0000

Minor ID: 0000

RSSI at 1 meter: -120dBm

In BT LE Data (LE\_bdaddr\_to\_mf\_specific), bdaddr\_random = 0 (Public)

This was found in an event of type 3 which corresponds to Non-Connectable Undirected Advertising (ADV\_NONCONN\_IND)

No Class of Device Data found.

No GATT Information found.

No BLE 2thprint Info found.

No BTC 2thprint Info found.

This was found in an event of type 3 which corresponds to Non-Connectable Undirected Advertising (ADV\_NONCONN\_IND)

No Class of Device Data found.

No GATT Information found.

No BLE 2thprint Info found.

=====  
For bdaddr = 88:6b:0f:0e:22:f0:

Company Name by IEEE OUI (88:6b:0f): Bluegiga Technologies 0Y

No BTC Extended Inquiry Result Device info.

No Names found.

No UUID16s found.

No transmit power found.

No Appearance data found.

Manufacturer-specific Data:

Device Company ID: 0x004c (Apple, Inc.) - take with a grain of salt

Endianness-flipped device company ID (in case the vendor ID is not accurate)

Raw Data: 0215f34ebac47cd74027878e55f4e71d030900000000088

Apple iBeacon:

UUID128: f34ebac4-7cd7-4027-878e-55f4e71d0309

Major ID: 0000

Minor ID: 0000

RSSI at 1 meter: -120dBm

In BT LE Data (LE\_bdaddr\_to\_mf\_specific), bdaddr\_range = 00000000-00000000

This was found in an event of type 3 which corresponds to Non-Connectable Undirected Advertising (ADV\_NONCONN\_IND)

No Class of Device Data found.

No GATT Information found.

No BLE 2thprint Info found.

No BTC 2thprint Info found.

**No! Therefore, there is a high probability that this UUID128, if present, is strongly indicative of Bluegiga/SiLabs chips!**

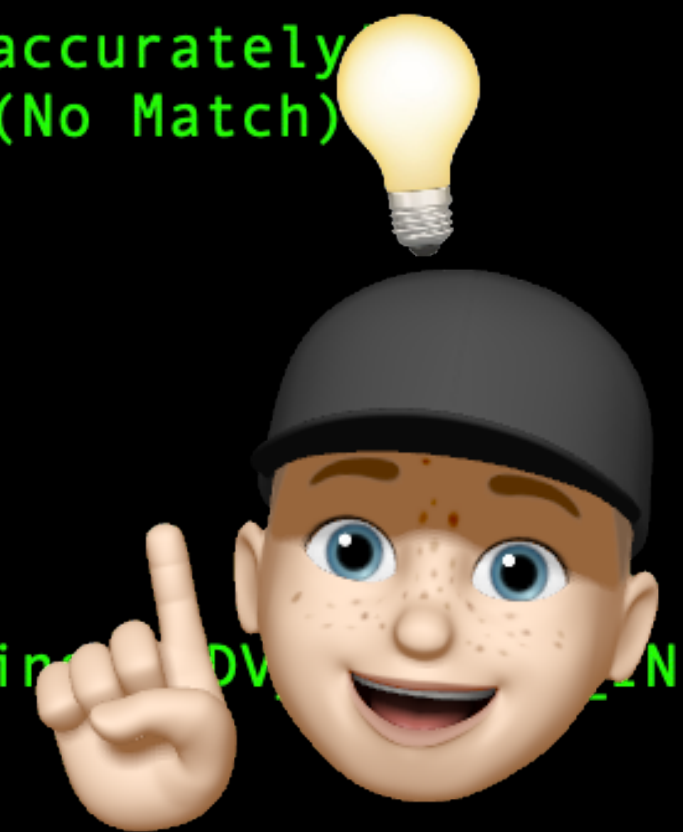





# iBeacon: "The other UUID128!"

## UUID128Print

- Detective Work 🕵️: GATT -> Google Search -> BLE112 == Bluegiga module -> Google Search -> Bluegiga == Silicon Labs -> iBeacons -> UUID128
- **UUID128 f34ebac4-7cd7-4027-878e-55f4e71d0309 == Bluegiga/Silicon chips!**
  - It doesn't hurt that the OUIPrint is corroborating ;)
- Note: I could be wrong, and it could be that this UUID128 is actually all Milwaukee equipment that is missing the other IDs like UUID16 or Milwaukee MSD or GATT info
- This is why we need more crowdsourced data!



# iBeacon: "The other UUID128!"

UUID128Print



# iBeacon: "The other UUID128!"

UUID128Print

- Plot Twist! The Bluegiga *module* was based on a TI *chip*!



# iBeacon: "The other UUID128!"

## UUID128Print

- Plot Twist! The Bluegiga *module* was based on a TI *chip*!

## 7 Block diagram

BLE112 is based on TI's CC2540 chip. Embedded 32 MHz and 32.678 kHz crystals are used for clock generation. Matched balun and low pass filter provide optimal radio performance with extremely low spurious emissions. Small ceramic chip antenna gives good radiation efficiency even when the module is used in layouts with very limited space. <https://www.silabs.com/documents/public/data-sheets/BLE112-DataSheet.pdf>



# iBeacon: "The other UUID128!"

## UUID128Print

- Plot Twist! The Bluegiga *module* was based on a TI *chip*!

## 7 Block diagram

BLE112 is based on TI's CC2540 chip. Embedded 32 MHz and 32.678 kHz crystals are used for clock generation. Matched balun and low pass filter provide optimal radio performance with extremely low spurious emissions. Small ceramic chip antenna gives good radiation efficiency even when the module is used in layouts with very limited space. <https://www.silabs.com/documents/public/data-sheets/BLE112-DataSheet.pdf>



# But sometimes...

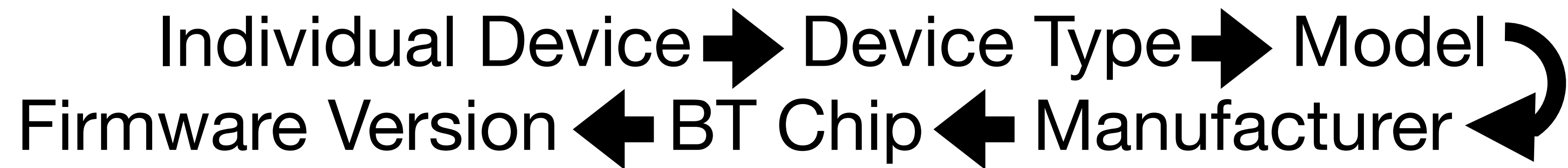



# But sometimes...

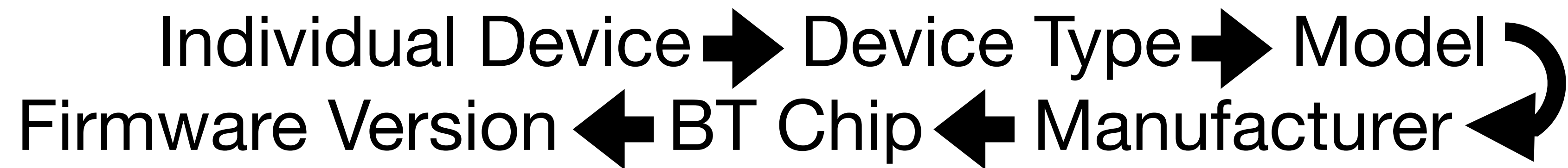

UUID128: **f34ebac4-7cd7-4027-878e-55f4e71d0309**



# But sometimes...

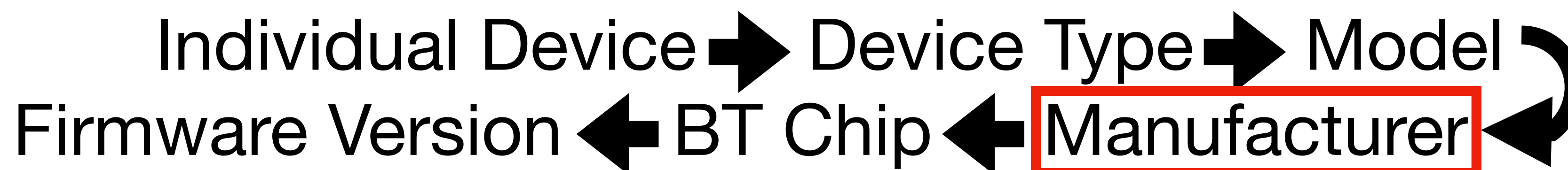

*Bluegiga*

UUID128Print  
DATABASE LOOKUP

UUID128: **f34ebac4-7cd7-4027-878e-55f4e71d0309**





# But sometimes...

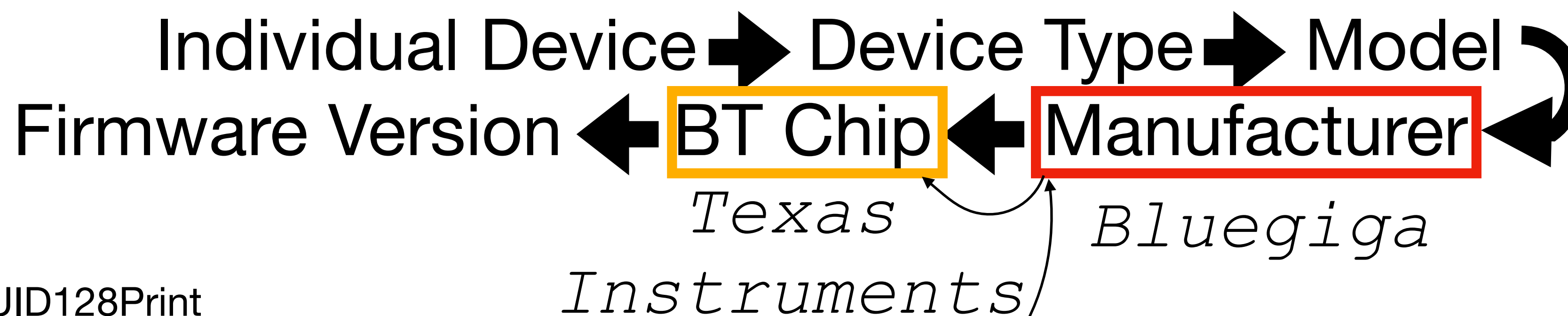

UUID128Print  
DATABASE LOOKUP

UUID128: **f34ebac4-7cd7-4027-878e-55f4e71d0309**



# But sometimes...

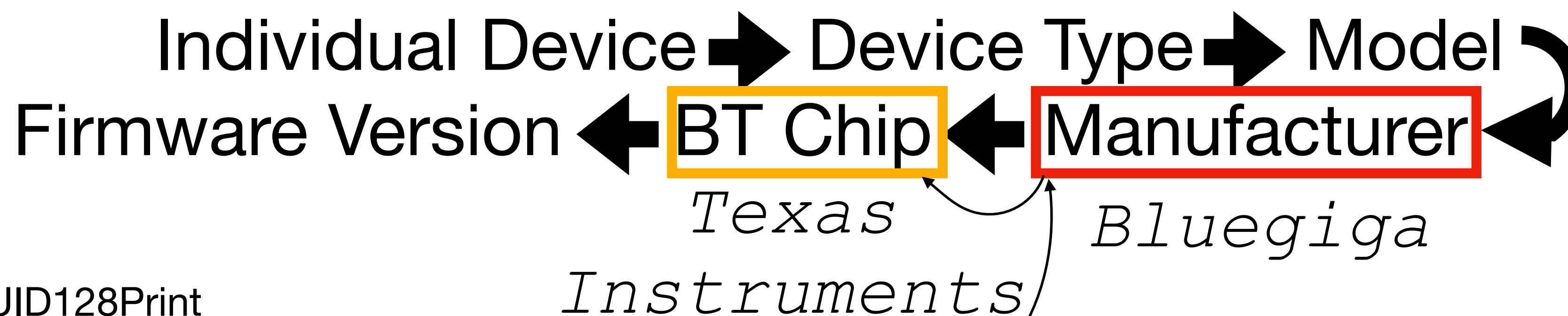

UUID128Print  
DATABASE LOOKUP

UUID128: **f34ebac4-7cd7-4027-878e-55f4e71d0309**

## ASSUMPTION:

UUID128Prints can be reused *within* Manufacturers,  
but not reused *between* Manufacturers

**2thprint by SDP**





# Prior Work

**"Blueprinting - Remote Device Identification based on Bluetooth Fingerprinting Techniques"**

- [1] by Herfurt & Mulliner from 2004 connected to BTC devices via Service Discovery Protocol (SDP) and created a hash from selected data within the available profiles
- I'm simply using the deprecated "sdptool" from BlueZ with its existing XML output option. *But I haven't decided how to process the data yet!*



# Prior Work

"Blueprinting - Remote Device Identification based on Bluetooth Fingerprinting Techniques"

- [1] by Herfurt & Mulliner from 2004 connected to BTC devices via Service Discovery Protocol (SDP) and created a hash from selected data within the available profiles
- I'm simply using the deprecated "sdptool" from BlueZ with its existing XML output option. *But I haven't decided how to process the data yet!*

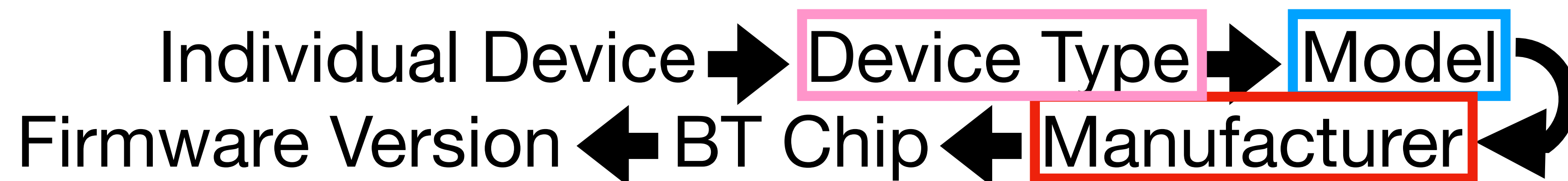

[1] <http://www.mulliner.org/collin/publications/Blueprinting.pdf>



# Prior Work

"Blueprinting - Remote Device Identification based on Bluetooth Fingerprinting Techniques"

- [1] by Herfurt & Mulliner from 2004 connected to BTC devices via Service Discovery Protocol (SDP) and created a hash from selected data within the available profiles
- I'm simply using the deprecated "sdptool" from BlueZ with its existing XML output option. *But I haven't decided how to process the data yet!*

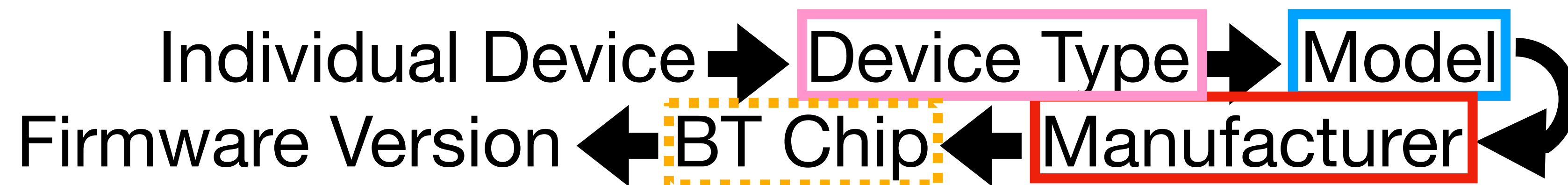

[1] <http://www.mulliner.org/collin/publications/Blueprinting.pdf>

# 2thprint by Class of Device





# 2thprint by Class of Device (CoD)

Primarily applicable to BTC (but some rare BLE devices use it too)

- BTC Extended Inquiry Response (EIR) packets contain a 24-bit CoD value

## 2.8 Class of Device

Referenced from the following:

- Bluetooth Core Specification [Vol 2] Part B, Section 6.5.1.4 [4].
- Supplement to the Bluetooth Core Specification Part A, Section 1.6.2 [22].

The Class of Device is composed of four fields: A Major Service Classes bitfield, a Major Device Class enumerated value, the Minor Device Classes, and a fixed value of 0b00 in the two least significant bits. The format of the Minor Device Class is determined by the Major Device Class value. The structure of the Class of Device is defined below:

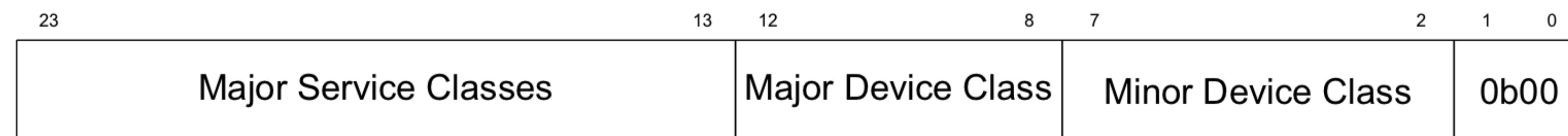

Figure 2.2: Class of Device format





## 2.8.2 Major Device Classes

The Miscellaneous major device class is used where a more specific Major Device Class code is not suitable. A device that does not have a major class code assigned can use the Uncategorized: device code not specified until "classified."

Last Modified: 2022-05-25

12	11	10	9	8	Major Device Class
0	0	0	0	0	Miscellaneous
0	0	0	0	1	Computer (desktop, notebook, PDA, organizer, ...)
0	0	0	1	0	Phone (cellular, cordless, pay phone, modem, ...)
0	0	0	1	1	LAN/Network Access point
0	0	1	0	0	Audio/Video (headset, speaker, stereo, video display, VCR, ...)
0	0	1	0	1	Peripheral (mouse, joystick, keyboard, ...)
0	0	1	1	0	Imaging (printer, scanner, camera, display, ...)
0	0	1	1	1	Wearable
0	1	0	0	0	Toy
0	1	0	0	1	Health
1	1	1	1	1	Uncategorized: device code not specified

## 2.8.1 Major Service Classes

Last Modified: 2022-05-25

Bit	Class of Device Major Service Class
13	Limited Discoverable Mode
14	LE audio
15	Reserved for future use
16	Positioning (Location identification)
17	Networking (LAN, Ad hoc, ...)
18	Rendering (Printing, Speakers, ...)
19	Capturing (Scanner, Microphone, ...)
20	Object Transfer (v-Inbox, v-Folder, ...)
21	Audio (Speaker, Microphone, Headset service, ...)
22	Telephony (Cordless telephony, Modem, Headset service, ...)
23	Information (WEB-server, WAP-server, ...)

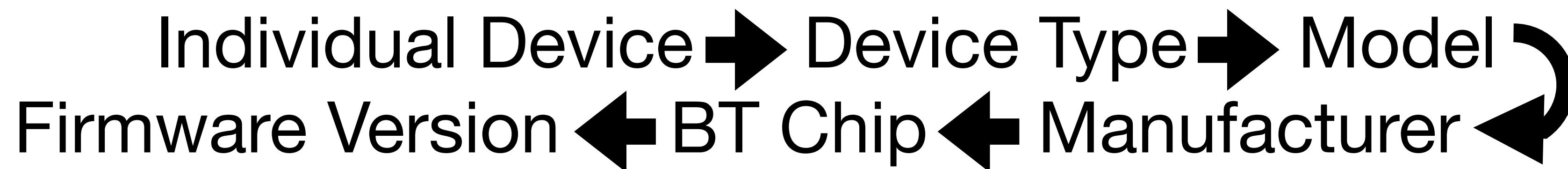



## 2.8.2 Major Device Classes

The Miscellaneous major device class is used where a more specific Major Device Class code is not suitable. A device that does not have a major class code assigned can use the Uncategorized: device code not specified until "classified."

Last Modified: 2022-05-25

12	11	10	9	8	Major Device Class
0	0	0	0	0	Miscellaneous
0	0	0	0	1	Computer (desktop, notebook, PDA, organizer, ...)
0	0	0	1	0	Phone (cellular, cordless, pay phone, modem, ...)
0	0	0	1	1	LAN/Network Access point
0	0	1	0	0	Audio/Video (headset, speaker, stereo, video display, VCR, ...)
0	0	1	0	1	Peripheral (mouse, joystick, keyboard, ...)
0	0	1	1	0	Imaging (printer, scanner, camera, display, ...)
0	0	1	1	1	Wearable
0	1	0	0	0	Toy
0	1	0	0	1	Health
1	1	1	1	1	Uncategorized: device code not specified

## 2.8.1 Major Service Classes

Last Modified: 2022-05-25

Bit	Class of Device Major Service Class
13	Limited Discoverable Mode
14	LE audio
15	Reserved for future use
16	Positioning (Location identification)
17	Networking (LAN, Ad hoc, ...)
18	Rendering (Printing, Speakers, ...)
19	Capturing (Scanner, Microphone, ...)
20	Object Transfer (v-Inbox, v-Folder, ...)
21	Audio (Speaker, Microphone, Headset service, ...)
22	Telephony (Cordless telephony, Modem, Headset service, ...)
23	Information (WEB-server, WAP-server, ...)

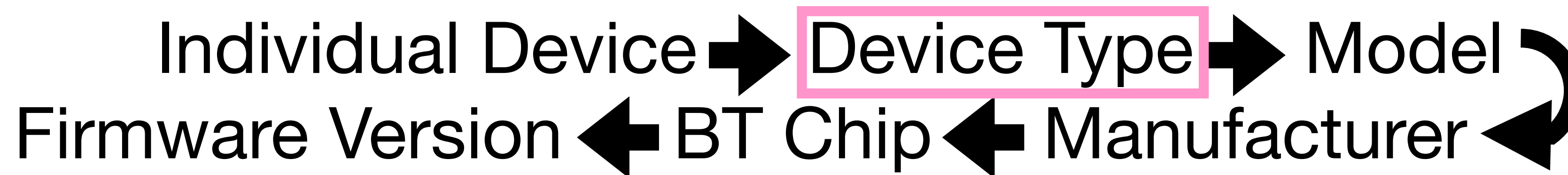

**2thprint by "Pics or it didn't happen"**





# 2thprint by looking up teardown pictures :P

**This is not scalable...unless we crowdsource it!**

- When one wants to know what a very specific device has for a chip, one can just google for teardown pictures!
- Sometimes the FCC (or other wireless regulatory authorities') database "internal photos" are useful in this regard

# E Tu Rivian?

- Regex: `^Rivian Sensor [1234]$\` e.g. Rivian Sensor 1
- Regex: `^Rivian Phone Key$\`
- Regex: `^Rivian Camp Speaker$\`



# E Tu Rivian?



- Regex: `^Rivian Sensor [1234]$` e.g. Rivian Sensor 1
- Regex: `^Rivian Phone Key$`
- Regex: `^Rivian Camp Speaker$`



Address type: **Public** (0x00)

Address: AC:4D:16:FD:40:93 (OUI AC-4D-16)

Name (complete): Rivian Sensor 3

# E Tu Rivian?



- Regex: `^Rivian Sensor [1234]$` e.g. Rivian Sensor 1
- Regex: `^Rivian Phone Key$`
- Regex: `^Rivian Camp Speaker$`



Address type: **Public** (0x00)

Address: AC:4D:16:FD:40:93 (OUI AC-4D-16) ← Actually Texas Instruments

Name (complete): Rivian Sensor 3

btmon just didn't have it in its vendor database

```
For bdaddr = AC:4D:16:FD:40:93:  
  Company Name by IEEE OUI (AC:4D:16): Texas Instruments  
  
No BTC Extended Inquiry Result Device info.  
  
DeviceName: Rivian Sensor 3  
  In BT LE Data (LE_bdaddr_to_name), bdaddr_random = 0 (Public)
```

# E TU

- Rege
- Rege
- Rege



Address  
Address  
Name (c

For bdaddr = A  
Compan  
No BTC  
Device

<https://apps.fcc.gov/e>

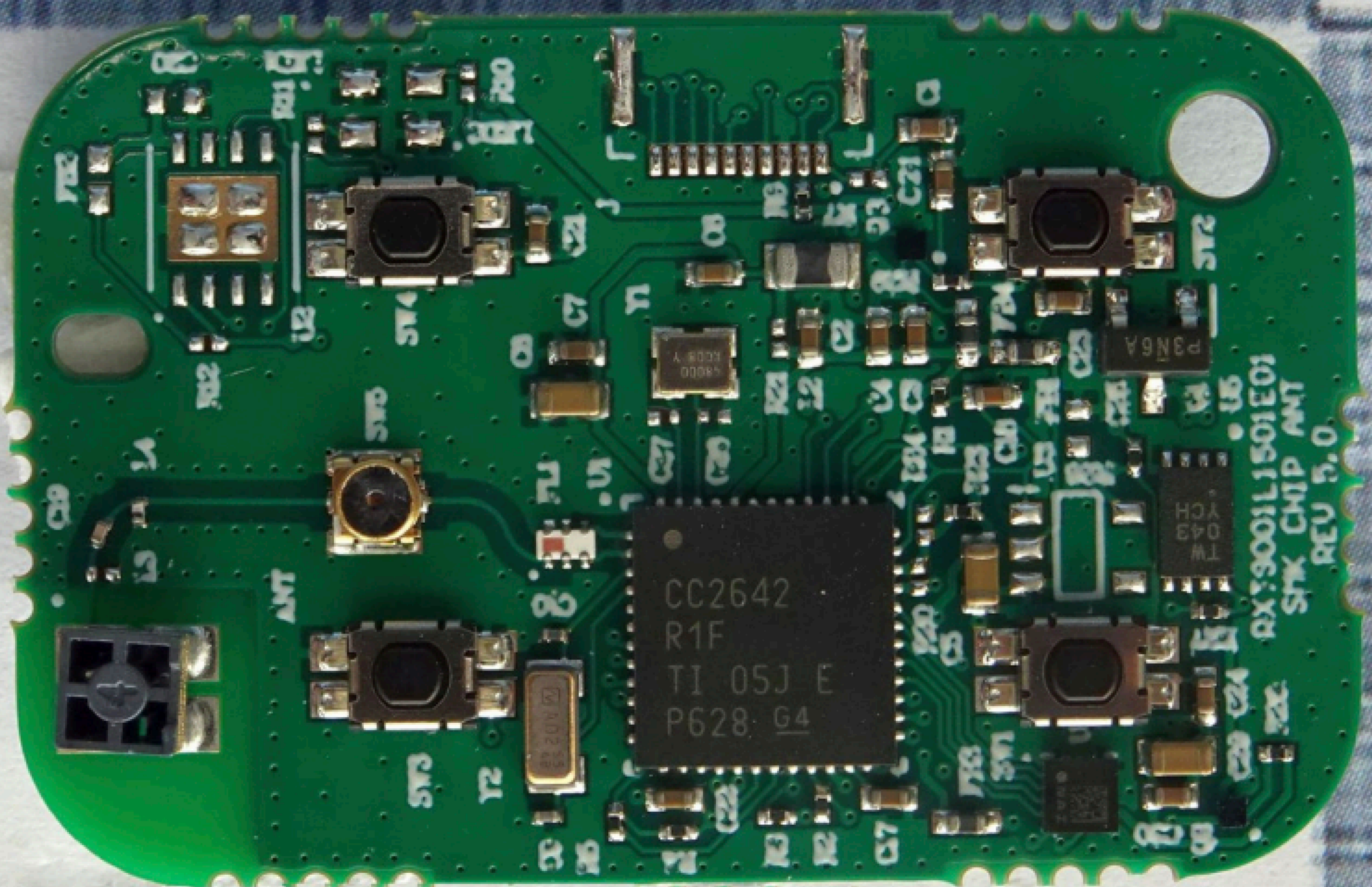



# E TU

- Rege
- Rege
- Rege



Address  
Address  
Name (c

For bdaddr = A  
Compan  
No BTC  
Device

<https://apps.fcc.gov/e>

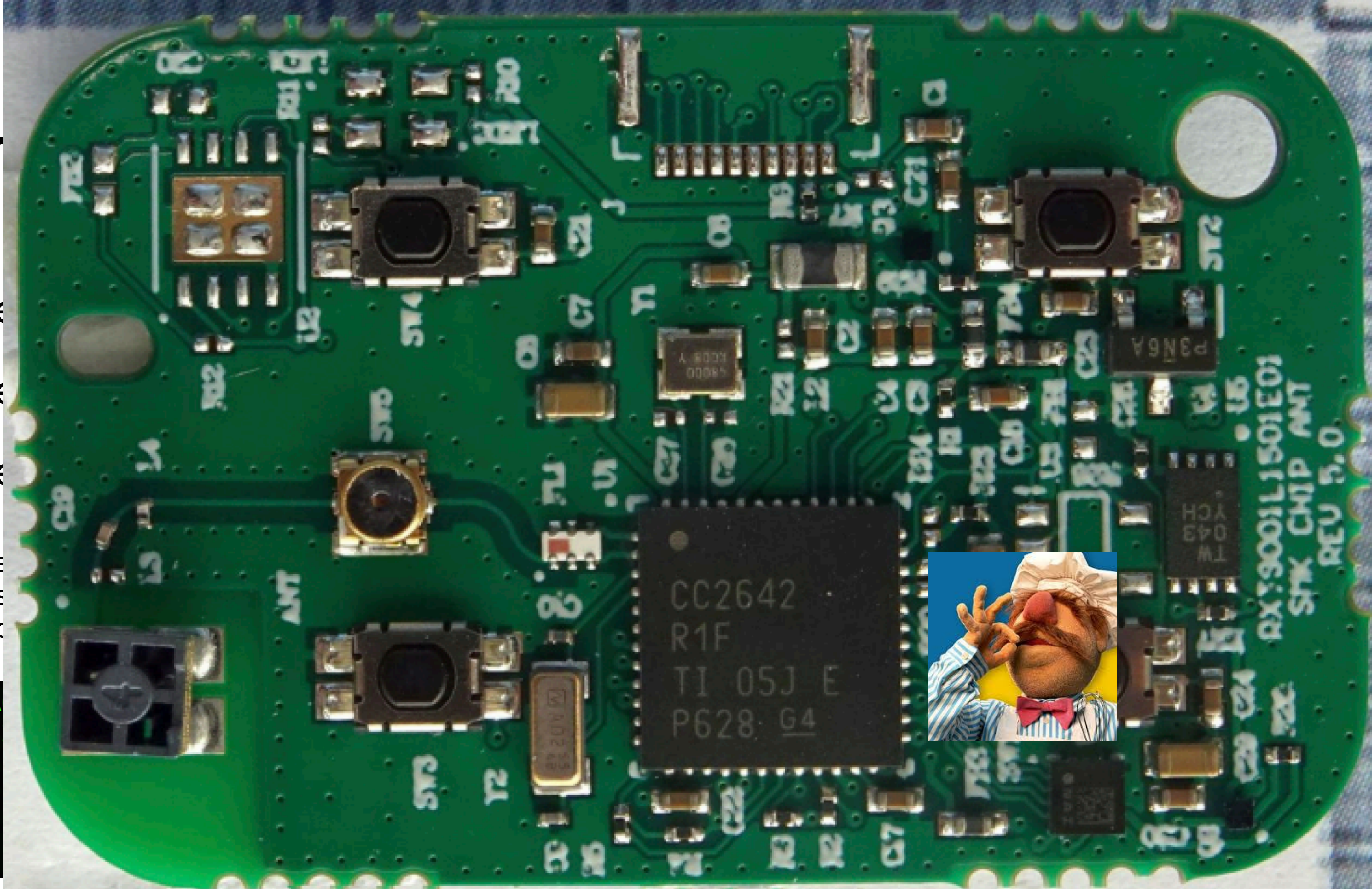

# Common Case

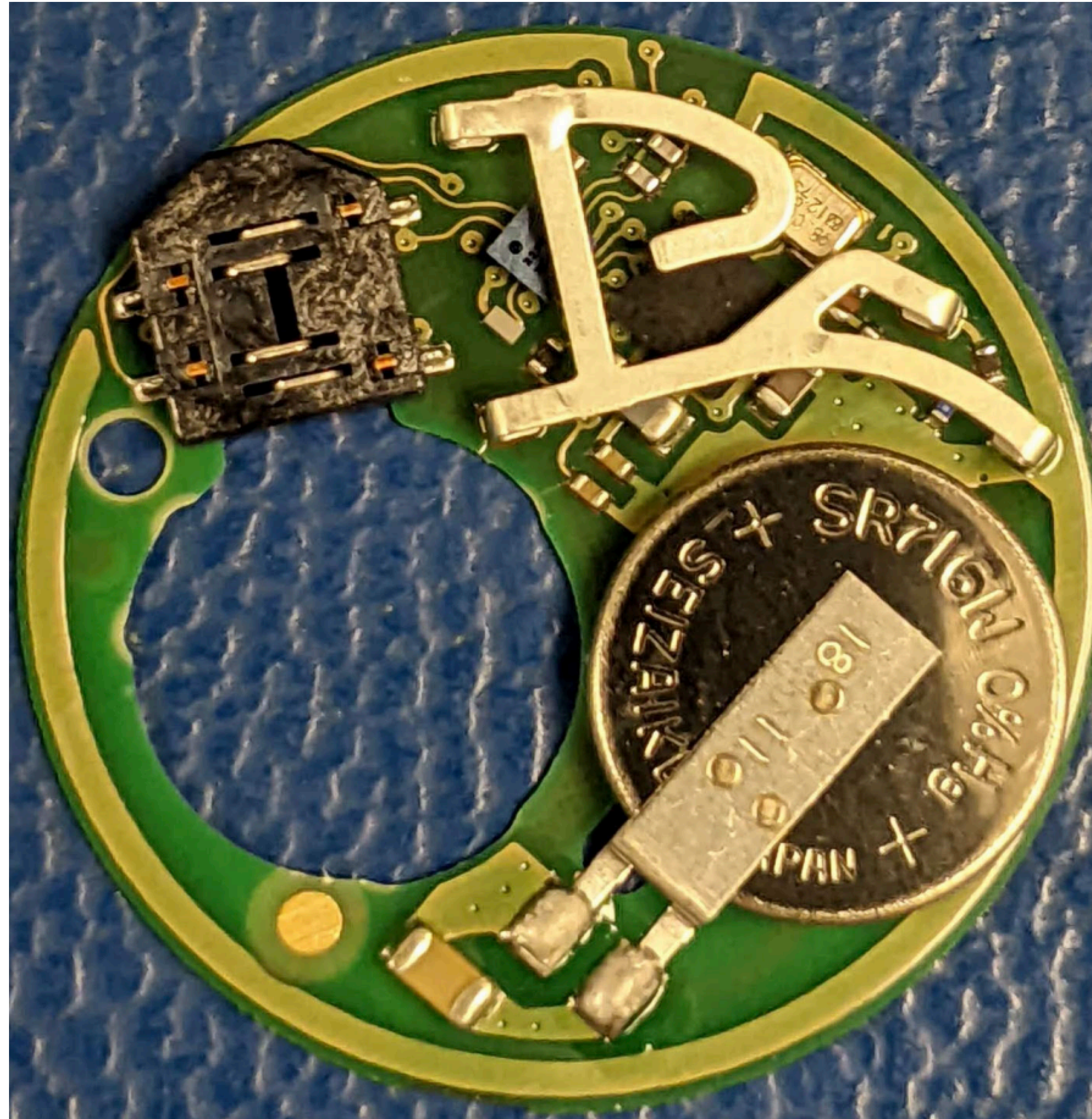

# Common Case

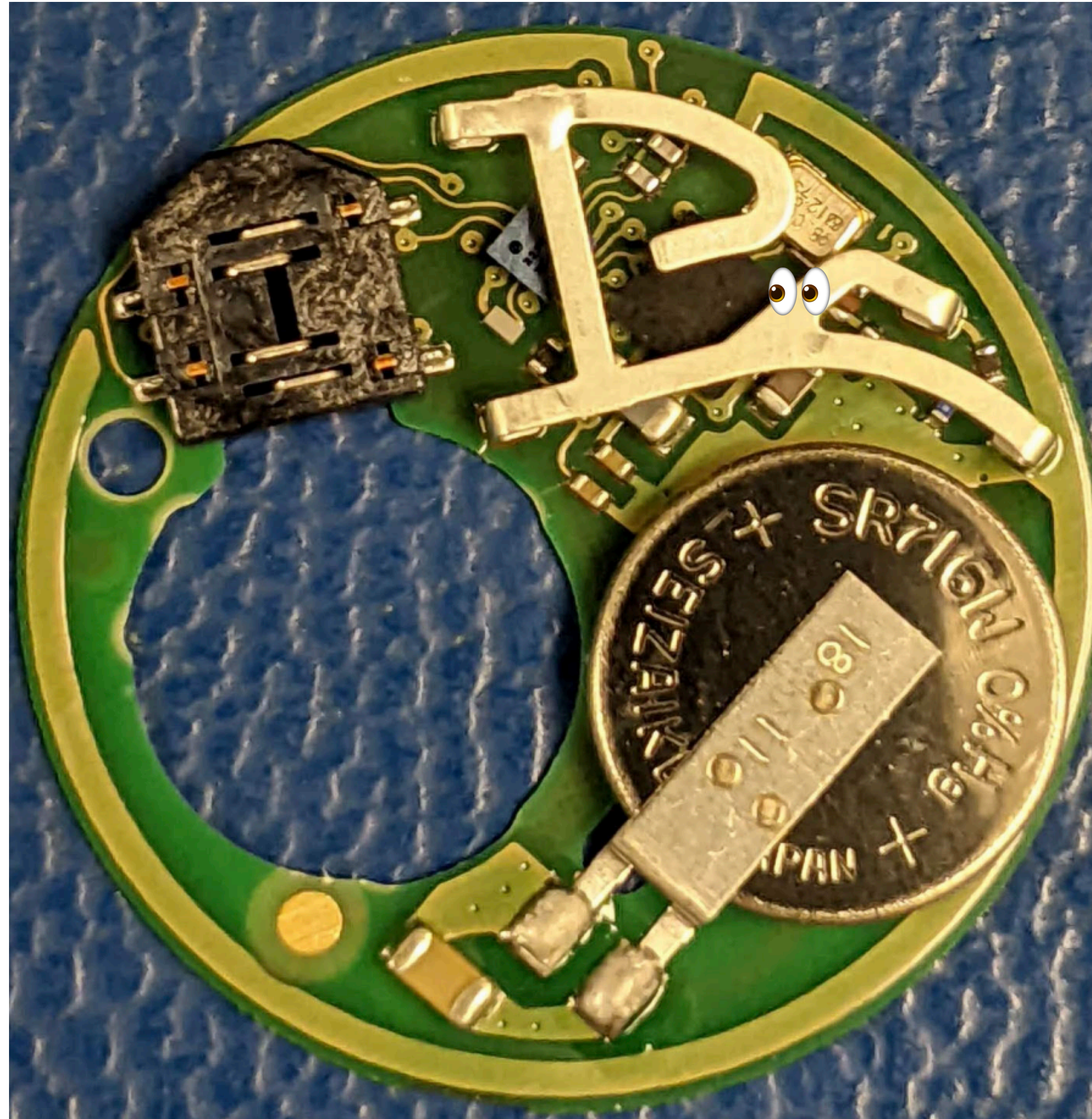

# Common Case

